



# INSTRUCTION & SAFETY MANUAL

SIL 3 Digital Output Driver,  
NE Loads, Loop Powered DIN-Rail and  
Termination Board, Models D5040S, D5040D



## Characteristics

**General Description:** The single or dual channel Loop Powered Digital Output Isolators, D5040S and D5040D, are suitable for driving solenoid valves, visual or audible alarms to alert a plant operator, or other process control devices in Hazardous Area from driving signals in Safe Area. They can also be used as controllable supplies to power measuring or process control equipment.

Their use is allowed in applications requiring up to SIL 3 level (according to IEC 61508:2010 Ed. 2) in safety related systems for high risk industries. The Safety PLC or DCS driving signals control the field devices through D5040S and D5040D, which provide isolation. For each channel two basic output circuits are selectable, with different safety parameters, to interface the majority of devices on the market. The selection among the two output characteristics is obtained by connecting the field device to a different couple of terminal blocks. Mounting on standard DIN-Rail or on customized Termination Boards, in Safe Area / Non Hazardous Location or in Zone 2 / Class I, Division 2 or Class I, Zone 2.

**Functional Safety Management certification:** G.M. International is certified by TUV to conform to IEC61508:2010 part 1 clauses 5-6 for safety related systems up to and included SIL3.



## Technical Data

### Loop Input:

loop powered control signal.

**Loop Supply:** 24 Vdc nom (18 to 30 Vdc) reverse polarity protected,

2 A time lag fuse internally protected.

**Current consumption @ 24 V:** 45 mA with 30 mA output for each channel of D5040D, typical in normal operation. 55 mA with 40 mA output (typical for D5040S).

**Power dissipation:** 0.75 W with 24 V supply, output energized at 35 mA nominal load for each channel of D5040D; 0.85 W with 24 V supply, output energized at 45 mA nominal load for D5040S.

### Isolation (Test Voltage):

I.S. Out/In 1.5 KV.

Out/Out 500 V.

In/In 500 V.

### Output:

See next page for detailed output diagrams and characteristics.

#### Short circuit current:

≥ 45 mA (50 mA typical) for single output configuration (D5040S);

≥ 35 mA (40 mA typical) for single output configurations (D5040D);

≥ 70 mA (80 mA typical) for parallel output configurations (D5040D).

**Response time:** ≤ 75 ms.

**Frequency response:** 50 Hz

### Compatibility:



CE mark compliant, conforms to Directive: 2014/34/EU ATEX, 2014/30/EU EMC, 2014/35/EU LVD, 2011/65/EU RoHS.

### Environmental conditions:

**Operating:** temperature limits – 40 to + 70 °C, relative humidity 95 %, up to 55 °C.

**Storage:** temperature limits – 45 to + 80 °C.

### Safety Description:



**ATEX:** II 3(1)G Ex nA [ja Ga] IIC T4 Gc, II (1)D [Ex ia Da] IIIC, I (M1) [Ex ia Ma] I

**IECEX:** Ex nA [ja Ga] IIC T4 Gc, [Ex ia Da] IIIC, [Ex ia Ma] I,

**UL:** NI / I / 2 / ABCD / T4, AIS / I, II, III / 1 / ABCDEFG, AEx nA [ja Ga] IIC T4 Gc

**C-UL:** NI / I / 2 / ABCD / T4, AIS / I, II, III / 1 / ABCDEFG, Ex nA [ja Ga] IIC T4 Gc

**UKR TR n. 898:** 2ExnAiaIICT4 X, Exial X

**KCs:** Ex nA [ja Ga] IIC T4 Gc

associated apparatus and non-sparking electrical equipment.

See next page for safety parameters.

Um = 250 Vrms, -40 °C ≤ Ta ≤ 70 °C.

### Approvals:

BVS 14 ATEX E 159 X conforms to EN60079-0, EN60079-11, EN60079-15

IECEX BVS 14.0111X conforms to IEC60079-0, IEC60079-11, IEC60079-15.

UL & C-UL E222308 conforms to UL913, UL 60079-0, UL60079-11, UL60079-15,

ANSI/ISA 12.12.01 for UL and CSA-C22.2 No.157-92, CSA-E60079-0, CSA-E60079-11, CSA-C22.2 No. 213 and CSA-E60079-15 for C-UL.

CUL 16.0036 X conforms to ДСТУ 7113, ГОСТ 22782.5-78, ДСТУ IEC 60079-15.

KTL 16-KA4BO-443X for KCs approval (for D5040S).

KTL 16-KA4BO-444X for KCs approval (for D5040D).

TÜV Certificate No. C-IS-236198-04, SIL 3 conforms to IEC61508:2010 Ed.2.

TÜV Certificate No. C-IS-236198-09, SIL 3 Functional Safety Certificate conforms to IEC61508:2010 Ed.2, for Management of Functional Safety.

DNV Type Approval Certificate No.A-13625 and KR No.MIL20769-EL002 Certificates for maritime applications.

### Mounting:

T35 DIN-Rail according to EN50022, or on customized Termination Board.

**Weight:** about 110 g.

**Connection:** by polarized plug-in disconnect screw terminal blocks to accommodate

terminations up to 2.5 mm<sup>2</sup>.

**Location:** installation in Safe Area/Non Hazardous Locations or Zone 2, Group IIC T4 or Class I, Division 2, Group A,B,C,D, T4 or Class I, Zone 2, Group IIC, T4.

**Protection class:** IP 20.

**Dimensions:** Width 12.5 mm, Depth 123 mm, Height 120 mm.

## Ordering Information

Model:	D5040	
1 channel		S
2 channels		D

DIN-Rail accessories:  
Cover and fix MCHP196

## Front Panel and Features



- SIL 3 according to IEC 61508:2010 Ed. 2 for lifetime = 20 yrs.
- PFDavg (1 year) 0.00 E+00, SFF 100 %.
- SIL 3 Systematic capability
- Output to Zone 0 (Zone 20), installation in Zone 2.
- Loop powered for NE loads.
- Output short circuit proof and current limited.
- Two port isolation, Input/Output.
- EMC Compatibility to EN61000-6-2, EN61000-6-4, EN61326-1, EN61326-3-1 for safety systems.
- ATEX, IECEx, UL & C-UL, UKR TR n. 898, KCs, TÜV Certifications.
- TÜV Functional Safety Certification.
- Type Approval Certificate DNV and KR for maritime applications.
- Simplified installation using standard DIN-Rail and plug-in terminal blocks, or customized Termination Boards.
- 250 Vrms (Um) max. voltage allowed to the instruments associated with the barrier.

## Terminal block connections

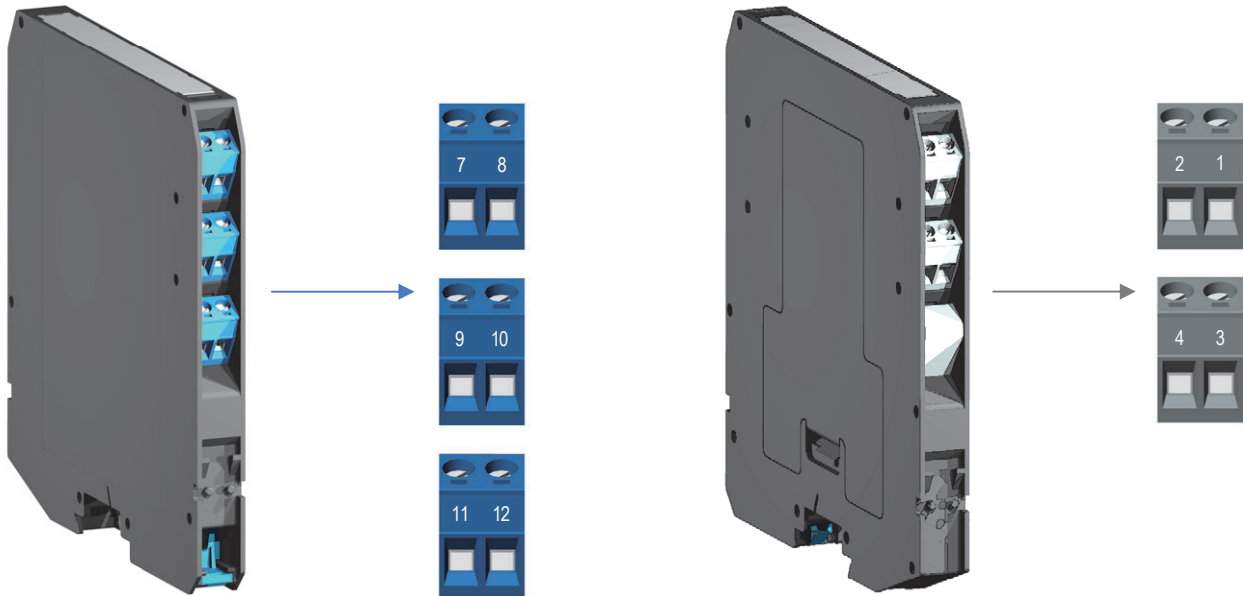

### HAZARDOUS AREA

7	+ Output , Ch 1 for Solenoid Valve
8	- Output A, Ch 1 for Solenoid Valve
9	- Output B, Ch 1 for Solenoid Valve
10	+ Output , Ch 2 for Solenoid Valve
11	- Output A, Ch 2 for Solenoid Valve
12	- Output B, Ch 2 for Solenoid Valve

### SAFE AREA

1	+ Input Ch 1
2	- Input Ch 1
3	+ Input Ch 2
4	- Input Ch 2

## Parameters Table

In the system safety analysis, always check the Hazardous Area/Hazardous Locations devices to conform with the related system documentation, if the device is Intrinsically Safe check its suitability for the Hazardous Area/Hazardous Locations and group encountered and that its maximum allowable voltage, current, power ( $U_i/V_{max}$ ,  $I_i/I_{max}$ ,  $P_i/P_i$ ) are not exceeded by the safety parameters ( $U_o/V_{oc}$ ,  $I_o/I_{sc}$ ,  $P_o/P_o$ ) of the D5040 series Associated Apparatus connected to it. Also consider the maximum operating temperature of the field device, check that added connecting cable and field device capacitance and inductance do not exceed the limits ( $C_o/C_a$ ,  $L_o/L_a$ ,  $L_o/R_o$ ) given in the Associated Apparatus parameters for the effective group. See parameters indicated in the table below:

D5040 Terminals		D5040 Associated Apparatus Parameters	Must be	Hazardous Area/ Hazardous Locations		
Ch1	7 - 8	$U_o / V_{oc} = 25.2 \text{ V}$	$\leq$	$U_i / V_{max}$		
Ch2	10 - 11					
Ch1	7 - 9	$U_o / V_{oc} = 25.2 \text{ V}$				
Ch2	10 - 12					
Ch 1//2	7 // 10 - 8 // 11	$U_o / V_{oc} = 25.2 \text{ V}$				
Ch 1//2	7 // 10 - 9 // 12					
Ch1//2	7 // 10 - 8 // 12	$U_o / V_{oc} = 25.2 \text{ V}$				
	or 7 // 10 - 9 // 11					
Ch1	7 - 8	$I_o / I_{sc} = 146 \text{ mA}$			$\leq$	$I_i / I_{max}$
Ch2	10 - 11					
Ch1	7 - 9	$I_o / I_{sc} = 108 \text{ mA}$				
Ch2	10 - 12					
Ch 1//2	7 // 10 - 8 // 11	$I_o / I_{sc} = 292 \text{ mA}$				
Ch 1//2	7 // 10 - 9 // 12					
Ch1//2	7 // 10 - 8 // 12	$I_o / I_{sc} = 254 \text{ mA}$				
	or 7 // 10 - 9 // 11					
Ch1	7 - 8	$P_o / P_o = 916 \text{ mW}$	$\leq$	$P_i / P_i$		
Ch2	10 - 11					
Ch1	7 - 9	$P_o / P_o = 676 \text{ mW}$				
Ch2	10 - 12					
Ch 1//2	7 // 10 - 8 // 11	$P_o / P_o = 1831 \text{ mW}$				
Ch 1//2	7 // 10 - 9 // 12					
Ch1//2	7 // 10 - 8 // 12	$P_o / P_o = 1592 \text{ mW}$				
	or 7 // 10 - 9 // 11					
D5040 Terminals	D5040 Associated Apparatus Parameters Cenelec (US)				Must be	Hazardous Area/ Hazardous Locations
Ch1	7 - 8	$C_o / C_a = 0.107 \mu\text{F}$			$\geq$	$C_i / C_i \text{ device} + C \text{ cable}$
		$C_o / C_a = 0.82 \mu\text{F}$				
Ch2	10 - 11	$C_o / C_a = 2.9 \mu\text{F}$				
		$C_o / C_a = 4.8 \mu\text{F}$				
Ch1	7 - 9	$C_o / C_a = 0.107 \mu\text{F}$				
		$C_o / C_a = 0.82 \mu\text{F}$				
Ch2	10 - 12	$C_o / C_a = 2.9 \mu\text{F}$				
		$C_o / C_a = 4.8 \mu\text{F}$				
Ch1 // Ch 2	7 // 10 - 8 // 11	$C_o / C_a = 0.82 \mu\text{F}$				
		$C_o / C_a = 2.9 \mu\text{F}$				
Ch1 // Ch 2	7 // 10 - 9 // 12	$C_o / C_a = 4.8 \mu\text{F}$				
		$C_o / C_a = 0.82 \mu\text{F}$				
Ch1 // Ch 2	7 // 10 - 8 // 12	$C_o / C_a = 0.82 \mu\text{F}$				
		$C_o / C_a = 2.9 \mu\text{F}$				
Ch1 // Ch 2	7 // 10 - 9 // 11	$C_o / C_a = 4.8 \mu\text{F}$				
		$C_o / C_a = 0.82 \mu\text{F}$				

D5040 Terminals		D5040 Associated Apparatus Parameters Cenelec (US)		Must be	Hazardous Area/ Hazardous Locations
Ch1	7 - 8	Lo / La = 1.67 mH	IIC (A, B)	≥	Li / Li device + L cable
		Lo / La = 6.7 mH	IIB (C)		
		Lo / La = 13.4 mH	IIA (D)		
Ch2	10 - 11	Lo / La = 22 mH	I		
		Lo / La = 6.7 mH	IIIC (E, F, G)		
Ch1	7 - 9	Lo / La = 3 mH	IIC (A, B)		
		Lo / La = 12.3 mH	IIB (C)		
		Lo / La = 24.6 mH	IIA (D)		
Ch2	10 - 12	Lo / La = 40 mH	I		
		Lo / La = 12.3 mH	IIIC (E, F, G)		
Ch1 // Ch 2	7 // 10 - 8 // 11	Lo / La = 1.67 mH	IIB (C)		
		Lo / La = 3.3 mH	IIA (D)		
		Lo / La = 5.5 mH	I		
		Lo / La = 1.67 mH	IIIC (E, F, G)		
Ch1 // Ch 2	7 // 10 - 9 // 12	Lo / La = 3 mH	IIB (C)		
		Lo / La = 6.1 mH	IIA (D)		
		Lo / La = 10.09 mH	I		
		Lo / La = 3 mH	IIIC (E, F, G)		
Ch1 // Ch 2	7 // 10 - 8 // 12 or 7 // 10 - 9 // 11	Lo / La = 2.2 mH	IIB (C)		
		Lo / La = 4.4 mH	IIA (D)		
		Lo / La = 7.28 mH	I		
		Lo / La = 2.2 mH	IIIC (E, F, G)		
Ch1	7 - 8	Lo / Ro = 38.8 μH/Ω	IIC (A, B)	≥	Li / Ri device and L cable / R cable
		Lo / Ro = 155.3 μH/Ω	IIB (C)		
		Lo / Ro = 310.7 μH/Ω	IIA (D)		
Ch2	10 - 11	Lo / Ro = 509.8 μH/Ω	I		
		Lo / Ro = 155.3 μH/Ω	IIIC (E, F, G)		
Ch1	7 - 9	Lo / Ro = 52.6 μH/Ω	IIC (A, B)		
		Lo / Ro = 210.4 μH/Ω	IIB (C)		
		Lo / Ro = 420 μH/Ω	IIA (D)		
Ch2	10 - 12	Lo / Ro = 690.3 μH/Ω	I		
		Lo / Ro = 210.4 μH/Ω	IIIC (E, F, G)		
Ch1 // Ch 2	7 // 10 - 8 // 11	Lo / Ro = 77.6 μH/Ω	IIB (C)		
		Lo / Ro = 155.3 μH/Ω	IIA (D)		
		Lo / Ro = 254.9 μH/Ω	I		
		Lo / Ro = 77.6 μH/Ω	IIIC (E, F, G)		
Ch1 // Ch 2	7 // 10 - 9 // 12	Lo / Ro = 105.2 μH/Ω	IIB (C)		
		Lo / Ro = 210.4 μH/Ω	IIA (D)		
		Lo / Ro = 345.1 μH/Ω	I		
		Lo / Ro = 105.2 μH/Ω	IIIC (E, F, G)		
Ch1 // Ch 2	7 // 10 - 8 // 12 or 7 // 10 - 9 // 11	Lo / Ro = 89.3 μH/Ω	IIB (C)		
		Lo / Ro = 178.7 μH/Ω	IIA (D)		
		Lo / Ro = 293.2 μH/Ω	I		
		Lo / Ro = 89.3 μH/Ω	IIIC (E, F, G)		

For installations in which both the Ci and Li of the Intrinsically Safe apparatus exceed 1 % of the Co and Lo parameters of the Associated Apparatus (excluding the cable), then 50 % of Co and Lo parameters are applicable and shall not be exceeded (50 % of the Co and Lo become the limits which must include the cable such that Ci device + C cable ≤ 50 % of Co and Li device + L cable ≤ 50 % of Lo).

If the cable parameters are unknown, the following values may be used: Capacitance 180pF per meter (60pF per foot), Inductance 0.60μH per meter (0.20μH per foot).

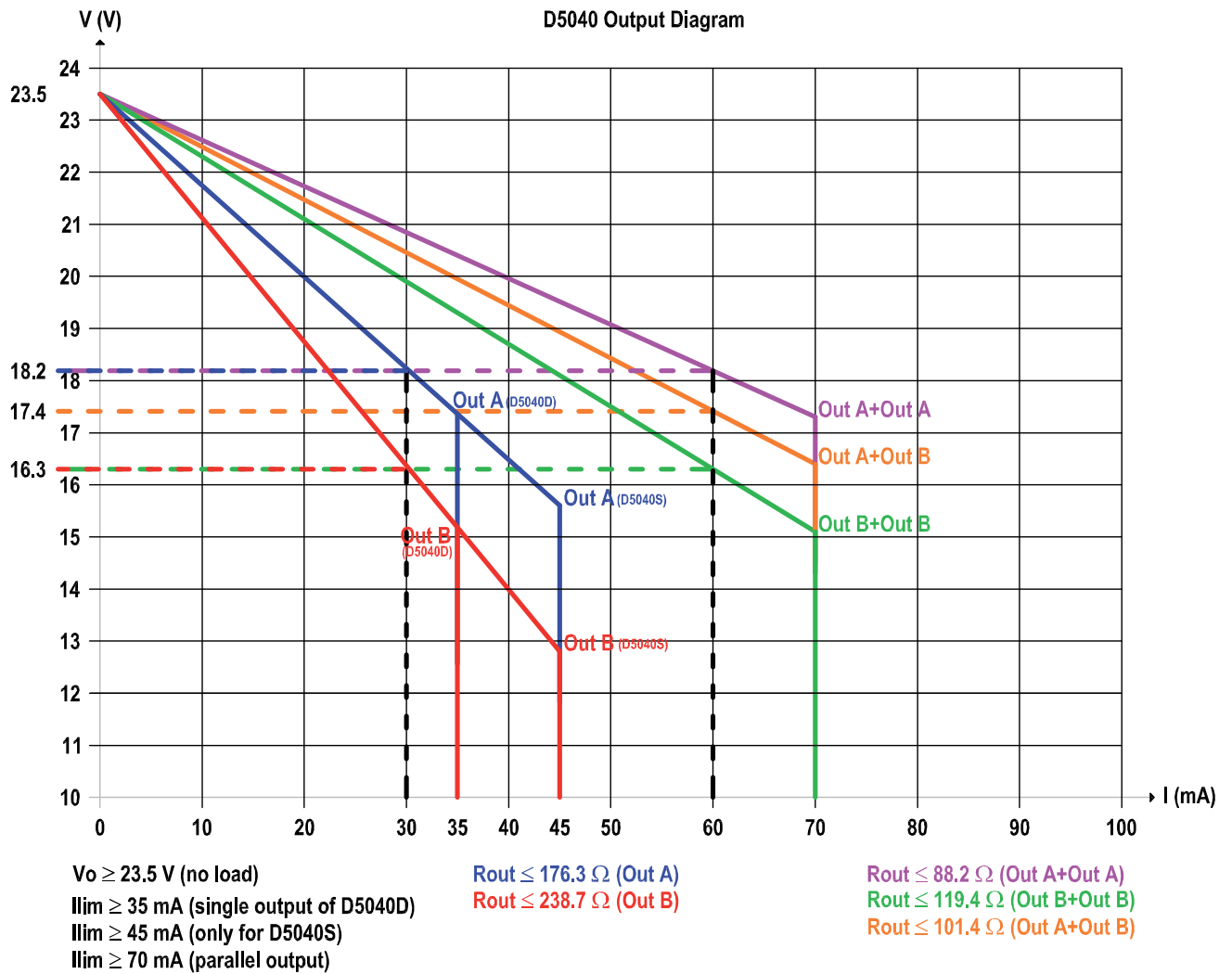

## Function Diagram

HAZARDOUS AREA ZONE 0 (ZONE 20) GROUP IIC,  
HAZARDOUS LOCATIONS CLASS I, DIVISION 1, GROUPS A, B, C, D,  
CLASS II, DIVISION 1, GROUPS E, F, G, CLASS III, DIVISION 1,  
CLASS I, ZONE 0, GROUP IIC

SAFE AREA, ZONE 2 GROUP IIC T4,  
NON HAZARDOUS LOCATIONS, CLASS I, DIVISION 2,  
GROUPS A, B, C, D T-Code T4, CLASS I, ZONE 2, GROUP IIC T4

**MODEL D5040S**

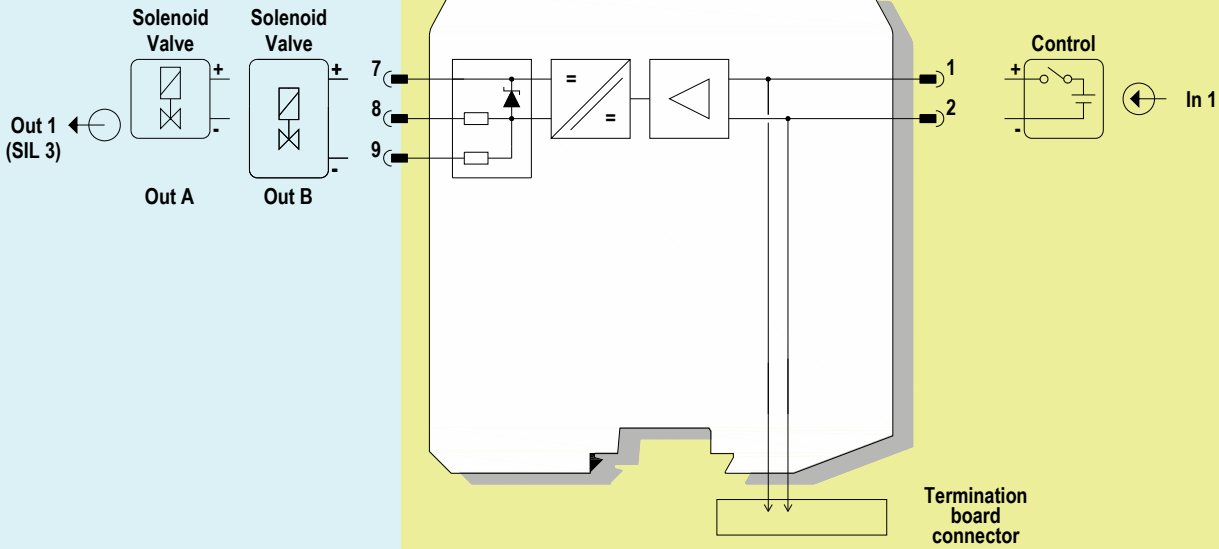

**MODEL D5040D**

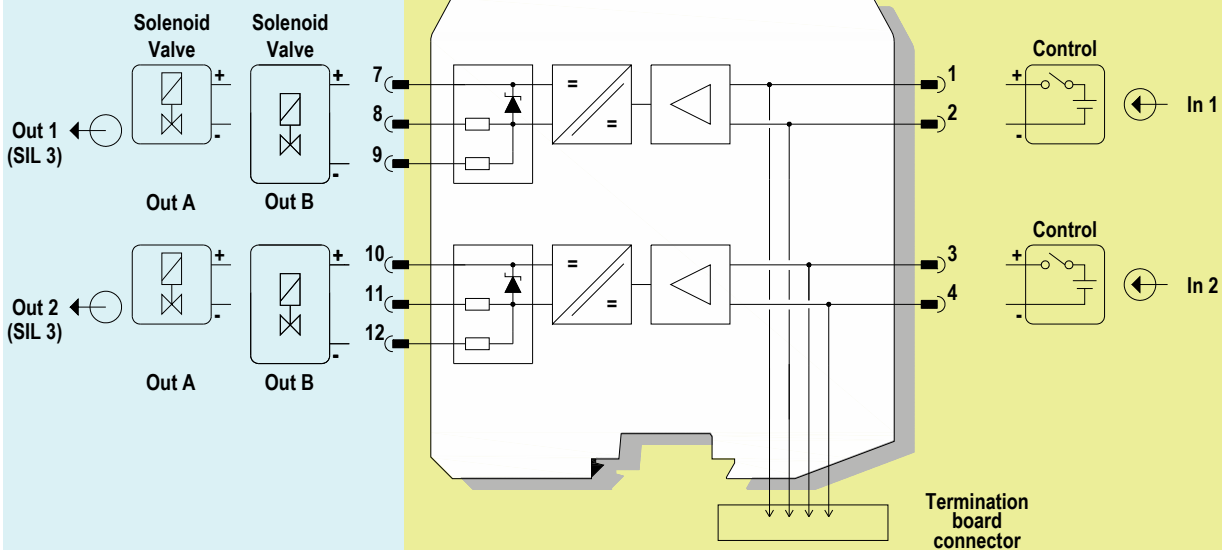

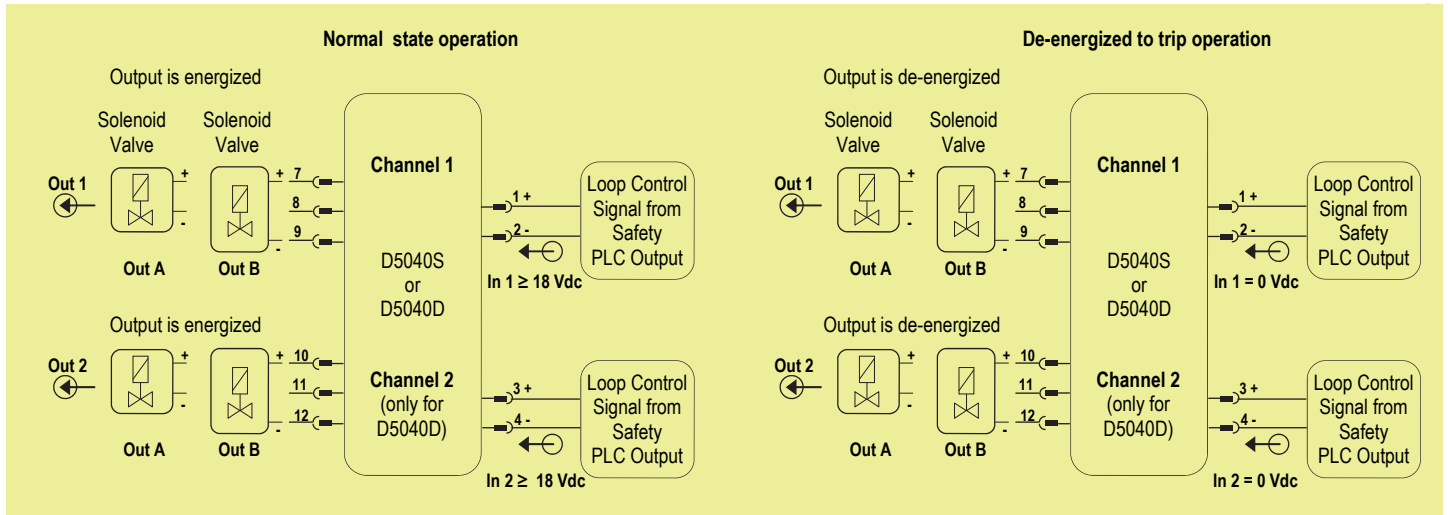

**Description:**

The D5040S (single channel) and D5040D (double channel) modules are single or double channel digital output drivers, loop powered for NE load (Normally Energized) loads. The Safety PLC or DCS driving/control signals power the field devices through the single or double channel digital output driver D5040S or D5040D (1 or 2 intrinsic safety channels, Loop Powered), which provides the electrical isolation between Input and Output. The presence of the input loop signal is also indicated by a yellow LED on the front panel (one for each channel).

In order to interface the majority of field devices available on the market, two basic output circuits with different safety parameters (outputs A and B) are provided for each channel. The selection among the two output characteristics is obtained by connecting the field devices to a different couple of terminal blocks.

Loop Control signals from Safety PLC Outputs are applied to Pins 1 - 2 (In. 1 - Ch. 1) and Pins 3 - 4 (In 2 - Ch. 2, only for D5040D).

The Output NE loads are connected to Pins 7 - 8 or 7 - 9 (for Channel 1) and Pins 10 - 11 or 10 - 12 (for Channel 2, only for D5040D).

The following table describes the state (de-energized or energized) of each output when its control signals in the High or Low state:

Operation	Input Signal State Pins 1 - 2 (In. 1 - Ch.1) or 3 - 4 (In 2 - Ch. 2, only D5040D)	Output State Pins 7 - 8 or 7 - 9 (Out. 1 - Ch.1) or 10 - 11 or 10 - 12 (Out 2 - Ch. 2, only D5040D)
Normal	High (18 to 30 Vdc)	Energized
Trip	Low (0 Vdc)	De-energized (as safe state condition)

**Safety Function and Failure behavior:**

D5040 is considered to be operating in Low Demand mode, as a Type A module, having Hardware Fault Tolerance (HFT) = 0.

The failure behaviour of D540S/D for NE loads is described by the following definitions :

- fail-Safe State: it is defined as the output being de-energized.
- fail Safe: failure mode that causes the module / (sub)system to go to the defined fail-safe state without a demand from the process;
- fail Dangerous: it is defined as a failure mode that does not respond to a demand from the process (i.e. being unable to go to the defined fail-safe state), so that output remains energized;
- fail "No Effect": failure mode of a component that plays a part in implementing the safety function but that is neither a safe failure nor a dangerous failure. When calculating the SFF, this failure mode is not taken into account;
- fail "Not part": failure mode of a component which is not part of the safety function but part of the circuit diagram and is listed for completeness. When calculating the SFF this failure mode is not taken into account.

The 2 channels of the D5040D module could be used to increase the hardware fault tolerance, needed for a higher SIL of a certain Safety Function, as they are completely independent one from each other, not containing common components. In fact, the analysis results got for D5040S (single channel) are also valid for each channel of D5040D (double channel). Since the loop powered modules are directly supplied by the digital output of a Safety PLC, if the safety PLC imposes a shutdown state of these modules, there is no additional power supply which can keep the D5040S and D5040D outputs energized in case of an internal fault. Therefore, all internal faults have either "no effect" on the safety function or lead to the safe state, according to the Safety Function definitions.

Failure rate data: taken from Siemens Standard SN29500.

**Failure rate table:**

Failure category	Failure rates (FIT)
$\lambda_{dd}$ = Total Dangerous Detected failures	0.00
$\lambda_{du}$ = Total Dangerous Undetected failures	0.00
$\lambda_{sd}$ = Total Safe Detected failures	0.00
$\lambda_{su}$ = Total Safe Undetected failures	104.46
$\lambda_{tot \text{ safe}}$ = Total Failure Rate (Safety Function) = $\lambda_{dd} + \lambda_{du} + \lambda_{sd} + \lambda_{su}$	104.46
MTBF (safety function, single channel) = $(1 / \lambda_{tot \text{ safe}}) + \text{MTTR (8 hours)}$	1092 years
$\lambda_{no \text{ effect}}$ = "No Effect" failures	102.54
$\lambda_{not \text{ part}}$ = "Not Part" failures	10.20
$\lambda_{tot \text{ device}}$ = Total Failure Rate (Device) = $\lambda_{tot \text{ safe}} + \lambda_{no \text{ effect}} + \lambda_{not \text{ part}}$	217.20
MTBF (device, single channel) = $(1 / \lambda_{tot \text{ device}}) + \text{MTTR (8 hours)}$	525 years
PFDAvg (TI = 1 year) = $\frac{1}{2} \lambda_{du} * 8760 \text{ h}$	0.00E+00

**Failure rates table according to IEC 61508:2010 Ed.2 :**

$\lambda_{sd}$	$\lambda_{su}$	$\lambda_{dd}$	$\lambda_{du}$	SFF
0.00 FIT	104.46 FIT	0.00 FIT	0.00 FIT	100%

Therefore, the D5040S and D5040D modules have SIL 3 level for lifetime of 20 years.

Systematic capability is SIL 3.

Since no dangerous undetected failures have been noted during the FMEDA analysis, there is no need to perform a proof test to reveal dangerous faults which cannot be otherwise detected.



## Warning

D5040S and D5040D are isolated Intrinsically Safe Associated Apparatus installed into standard EN50022 T35 DIN-Rail located in Safe Area or Zone 2, Group IIC, Temperature T4, Hazardous Area (according to EN/IEC60079-15) within the specified operating temperature limits Tamb -40 to +70 °C, and connected to equipment with a maximum limit for AC power supply Um of 250 Vrms.

Not to be connected to control equipment that uses or generates more than 250 Vrms or Vdc with respect to earth ground.

D5040S and D5040D must be installed, operated and maintained only by qualified personnel, in accordance with the relevant national/international installation standards (e.g. IEC/EN60079-14)

Electrical apparatus for explosive gas atmospheres - Part 14: Electrical installations in hazardous areas (other than mines)), following the established installation rules, particular care must be given to segregation and clear identification of I.S. conductors from non I.S. ones.

De-energize power source (turn off power supply voltage) before plugging or unplugging the terminal blocks when installed in Hazardous Area or unless the area is known to be nonhazardous.

**Warning: substitution of components may impair Intrinsic Safety and suitability for Zone 2.**

**Explosion Hazard: to prevent ignition of flammable or combustible atmospheres, disconnect power before servicing or unless area is known to be nonhazardous.**

Failure to properly installation or use of the equipment may risk to damage the unit or severe personal injury.

The unit cannot be repaired by the end user and must be returned to the manufacturer or his authorized representative.

Any unauthorized modification must be avoided.

## Operation

The single and double channel Loop Powered Digital Output Isolators, D5040S and D5040D, are suitable for driving solenoid valves, visual or audible alarms to alert a plant operator, or other process control devices in Hazardous Area from driving signal in Safe Area. The presence of the input signal is also indicated by a yellow LED (one for each channel). They can also be used as a controllable supply to power measuring or process control equipment.

Their use is allowed in applications requiring up to SIL 3 level (according to IEC 61508) in safety related systems for high risk industries. The Safety PLC or DCS driving signals power the field device through the D5040S and D5040D, which provides isolation.

Two basic output circuits for each channel are selectable, with different safety parameters, to interface the majority of devices on the market. The selection among the two output characteristics is obtained by connecting the field device to a different couple of terminal blocks.

## Installation

D5040S and D5040D are Digital Output Driver housed in a plastic enclosure suitable for installation on T35 DIN-Rail according to EN50022, or on customized Termination Board.

D5040S and D5040D units can be mounted with any orientation over the entire ambient temperature range.

Electrical connection of conductors up to 2.5 mm<sup>2</sup> are accommodated by polarized plug-in removable screw terminal blocks which can be plugged in/out into a powered unit without suffering or causing any damage (**for Zone 2 installations check the area to be nonhazardous before servicing**).

The wiring cables have to be proportionate in base to the current and the length of the cable.

In the section "Function Diagram" and enclosure side, a block diagram identifies all connections.

Identify the function and location of each on the connection terminal using the wiring diagram on the corresponding section, as an example:

Connect positive input at terminal "1" and negative input at "2" (or "3" and "4" for channel 2).

Connect positive output A for solenoid valve to terminal "7" and negative at "8" or output B to terminal "7" and negative to "9" (or "10" and "11" or "10" and "12" for channel 2).

Intrinsically Safe conductors must be identified and segregated from non I.S. and wired in accordance to the relevant national/international installation standards (e.g. EN/IEC60079-14 Electrical apparatus for explosive gas atmospheres - Part 14: Electrical installations in hazardous areas (other than mines)), make sure that conductors are well isolated from each other and do not produce any unintentional connection.

The enclosure provides, according to EN60529, an IP20 minimum degree of mechanical protection (or similar to NEMA Standard 250 type 1) for indoor installation, outdoor installation requires an additional enclosure with higher degree of protection (i.e. IP54 to IP65 or NEMA type 12-13) consistent with the effective operating environment of the specific installation.

Units must be protected against dirt, dust, extreme mechanical (e.g. vibration, impact and shock) and thermal stress, and casual contacts.

If enclosure needs to be cleaned use only a cloth lightly moistened by a mixture of detergent in water.

**Electrostatic Hazard: to avoid electrostatic hazard, the enclosure of D5040 must be cleaned only with a damp or antistatic cloth.**

Any penetration of cleaning liquid must be avoided to prevent damage to the unit. Any unauthorized card modification must be avoided.

## Start-up

Before powering the unit, check that all wires are properly connected and verify their polarity, also check that Intrinsically Safe conductors and cable trays are segregated (no direct contacts with other non I.S. conductors) and identified either by color coding, preferably blue, or by marking. Check conductors for exposed wires that could touch each other causing dangerous unwanted shorts. The status yellow LED must be in accordance with the condition of the corresponding input line.