

**BR323AL and BR323SS**  
**Flameproof**  
**Loop powered**  
**field mounting**  
**indicators**

CE UK  
CA Issue: 14

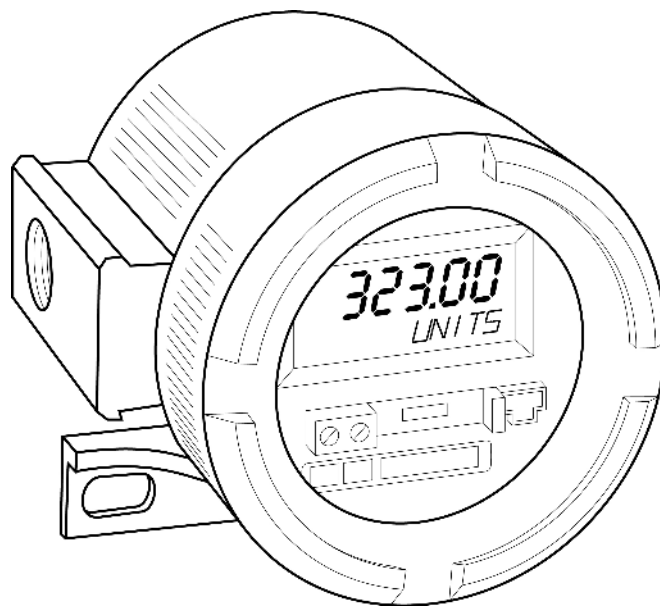

**CONTENTS**

- 1. Description**
- 2. Controls**
- 3. Flameproof Certification**
  - 3.1 ATEX certificate
  - 3.2 Flammable gases
  - 3.3 Combustible dusts
  - 3.4 Certification label information
- 4. System Design for use in Hazardous Areas.**
- 5. Installation**
  - 5.1 Location
  - 5.2 Installation procedure
  - 5.3 EMC
- 6. Programming and Calibration**
  - 6.1 Loading BEKA software onto a PC
  - 6.2 Connecting BR323 to PC
  - 6.3 Calibration screen
  - 6.4 Linear calibration
  - 6.5 Non-linear calibration
  - 6.6 Square root extraction
- 7. Maintenance**
  - 7.1 Fault finding during commissioning
  - 7.2 Fault finding after commissioning
  - 7.3 Servicing
  - 7.4 Routine maintenance
  - 7.5 Guarantee
  - 7.6 Customer comments
- 8. Accessories**
  - 8.1 Pipe mounting kit
  - 8.2 Tag strip
  - 8.3 Tag plate

**The BR323AL and BR323SS are CE marked to show compliance with the European Explosive Atmospheres Directive 2014/34/EU and the European EMC Directive 2014/30/EU.**

## 1. DESCRIPTION

The BR323AL and BR323SS are flameproof, field mounting, loop powered 5 digit indicators which display the current flowing in a 4/20mA loop in engineering units. The instruments only introduce a 2.3V drop allowing them to be installed into almost any 4/20mA loop.

The main application of these loop powered indicators is to display a measured variable or control signal in a hazardous process area. The zero and span of the digital display are configurable via a temporary serial data link using the free Windows® compatible BEKA software. This software also enables linear, square root or custom linearisation to be selected and the units of measurement legend, which appears below the main display, to be entered.

The two models are functionally identical. The BR323AL is housed in a polyester powder coated flameproof aluminium enclosure and the BR323SS is in a 316 stainless steel flameproof enclosure. Both enclosures provide IP66 & NEMA Type 4X protection. In this instruction manual BR323 refers to the removable electronic assembly which is common to both the BR323AL and the BR323SS.

Both instruments have been certified flameproof and comply with the European ATEX Directive 2014/34/EU.

The BR323 removable electronic assembly, which is common to both models may only be installed in a hazardous area when mounted within a flameproof BR323AL aluminium or BR323SS stainless steel enclosure.

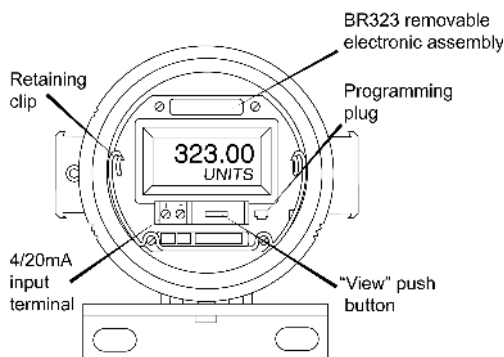

Fig 1 BR323AL or BR323SS without cover

## 2. CONTROLS

Both the BR323AL and BR323SS 4/20mA indicators are configured and calibrated by BEKA software running on a PC connected via a temporary serial data link, the indicators therefore do not have conventional calibration controls. Calibration can be rapidly checked, but not changed, using the 'view' push button which is located on the right hand side of the instrument terminals. Successive operation of this button steps the instrument display through the calibration parameters as shown in Fig 2.

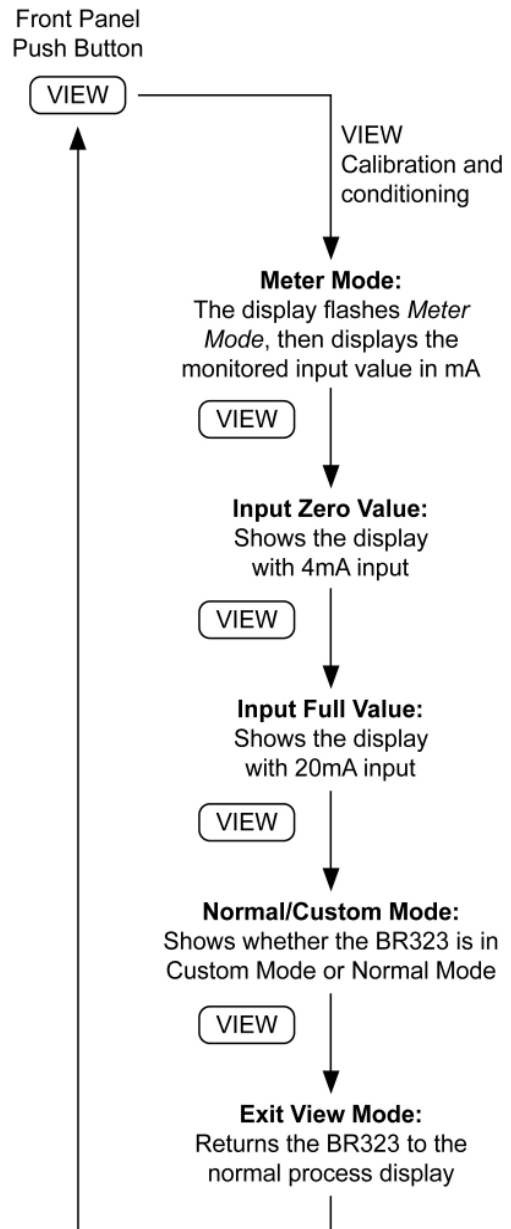

Fig 2 View menu

### 3. FLAMEPROOF CERTIFICATION

#### **CAUTION**

The BR323 removable electronic assembly, which is common to both models, may only be installed in a hazardous area when mounted within a flameproof BR323AL aluminium or BR323SS stainless steel enclosure.

#### 3.1 ATEX certificate

Notified Body ISSeP has issued the instruments with an EC-Type Examination Certificate ISSeP08ATEX035X that confirms compliance with the European ATEX Directive 2014/34/EU for Group II surface industries, Category 2GD flammable gas and combustible dust atmospheres, Ex d IIC T6. Copies of the certificate may be downloaded from [www.beka.co.uk](http://www.beka.co.uk). The instruments bear the Community Mark and, subject to local codes of practice, may be installed in any of the European Economic Area (EEA) member countries. ATEX certificates are also acceptable for installations in the UK until 1st January 2025.

#### 3.2 Flammable Gases

##### Zones, gas groups and T rating

Group II, Category 2G, Ex d IIC T6 certification allows the BR323AL and BR323SS indicators to be installed in:

- |        |   |
|--------|---|
| Zone 1 | explosive gas air mixture likely to occur in normal operation.                                  |
| Zone 2 | explosive gas air mixture not likely to occur, and if it does will only exist for a short time. |

Be used with gases in groups:

- |       |   |          |
|-------|---|----------|
| Group | A | propane  |
| Group | B | ethylene |
| Group | C | hydrogen |

Having a temperature classification of:

- |    |       |
|----|-------|
| T1 | 450°C |
| T2 | 300°C |
| T3 | 200°C |
| T4 | 135°C |
| T5 | 100°C |
| T6 | 85°C  |

At ambient temperatures between -20 and +60°C.

This allows both models to be installed in most hazardous areas and to be used with most common industrial gases.

This manual describes installations in flammable gas atmospheres which conform with EN60079:Part14 Electrical Installation in Hazardous Areas. When designing systems for installation outside the UK, the local Code of Practice should be consulted.

#### 3.3 Combustible Dusts

Both the BR323AL and BR323SS enclosures have been ATEX certified as Group II, Category 2D apparatus with a Maximum Surface Temperature of 85°C. When installed as specified by EN 61241-14 'Selection and installation of electrical apparatus for use in the presence of combustible dust', the indicator may be installed in:

Zone 21 where explosive atmosphere in the form of a cloud of combustible dust in air is likely to occur occasionally in normal operation.

Zone 22 where explosive atmosphere in the form of a cloud of combustible dust in air is not likely to occur in normal operation, but if it does occur, will only persist for a short period.

Be used with dusts having a Minimum Ignition Temperature of:

Dust cloud 127°C

Dust layer on BR323AL or BR323SS up to 5mm thick. 160°C

Dust layer on BR323AL or BR323SS over EN61241-14 5mm thick. Refer to

At an ambient temperature between -20 and +60°C

#### **NOTE**

##### **Special Conditions for Safe Use**

The ATEX certificate specifies that any accumulation of dust on the enclosure shall be avoided.

**3.4 Certification label information**

The certification information label is fitted in a recess on the top outer surface of the flameproof enclosure. It shows details of the ATEX certification, BEKA associates name and location, plus the year of manufacture.



BR323AL which has an aluminium enclosure



BR323SS which has a stainless steel enclosure

Fig 3 Certification Information Labels

**4. SYSTEM DESIGN FOR USE IN HAZARDOUS AREAS**

BR323AL and BR323SS indicators may be connected in series with any 4/20mA current loop having a maximum supply voltage of 30V dc and a maximum current of less than 110mA. It is only necessary to ensure that the loop can support the additional 2.3V drop introduced by the indicator.

Fig 4 illustrates a typical application in which a BR323AL or BR323SS indicator is connected in series with a 2-wire transmitter and calibrated to display the measured variable or control signal in engineering units.

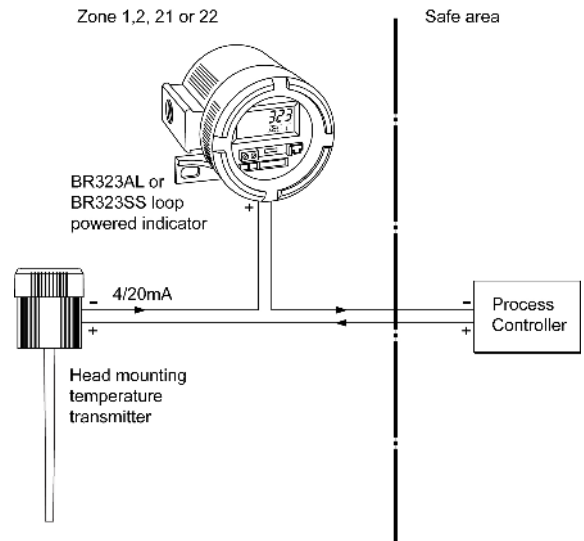

Fig 4 Typical transmitter loop

## 5. INSTALLATION

### 5.1 Location

The appropriate model BR323AL or BR323SS should be chosen depending on the severity of the environment. The BR323AL is housed in a polyester powder coated aluminium enclosure and the BR323SS in a 316 stainless steel enclosure suitable for marine applications. Both provide IP66 and NEMA Type 4X protection.

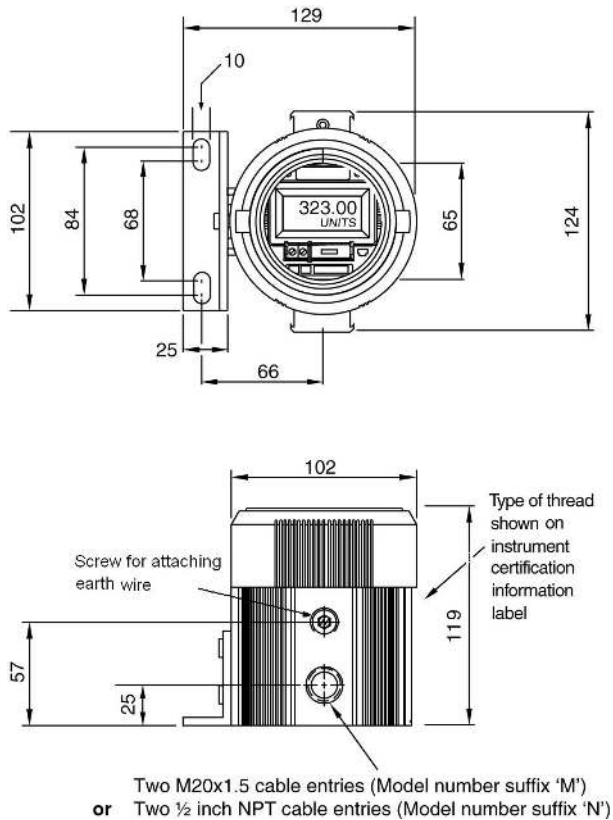

Fig 5 BR323AL & BR323SS dimensions

### 5.2 Installation procedure

#### WARNING

Installation of a BR323AL or BR323SS loop powered indicator should only be performed in a potentially hazardous area when an explosive atmosphere is NOT present.

Ensure that glands, blanking plugs or conduit connected to the indicator have the same thread as the indicator enclosure, which is shown on the instrument certification label.

Recommended installation procedure:

- Remove the flameproof enclosure cover that contains the viewing window by rotating anticlockwise.
- Remove the BR323 electronic assembly from the enclosure by gently squeezing the retaining clip and pulling – see Fig 1. If necessary remove the screw securing the earthing wire connecting the electronic assembly to the enclosure.
- Install the flameproof enclosure in the required position and secure using the two M10 mounting slots. The flameproof enclosure should be earthed as specified by the local code of practice.
- Fit the required flameproof certified glands or blanking plugs with the correct thread into the two entries in the enclosure. Instruments can have M20 x 1.5 threads (M suffix on product number) or ½ inch NPT entries (N suffix on product number). The instrument enclosure thread is shown on the instrument certification label. The installation must be as specified by the manufacturer of the certified gland or blanking plug and comply with the local code of practice. Alternatively, correctly threaded metal conduit may be used with a flameproof certified compound filled stopping box at each of the two entries. Installation must be as specified by the manufacturer of the stopping box and comply with the local code of practice.
- Position the electronic assembly in the flameproof enclosure and connect the two input terminals as shown in Figs 1 and 4. If removed, the earthing cable should be reconnected between the electronic assembly and the flameproof enclosure.
- Replace the flameproof enclosure cover by rotating clockwise and tighten until the sealing gasket is compressed.

### 5.3 EMC

The BR323AL and BR323SS comply with the requirements of the European EMC Directive Directive 2014/30/EU. For specified immunity all wiring should be in screened twisted pairs, with the screens earthed at one point in the safe area.

## 6. PROGRAMMING & CALIBRATION

The BR323AL and BR323SS 4/20mA indicators are configured and calibrated using BEKA configuration software running on a personal computer connected via a temporary serial data link.

### WARNING

**The temporary serial data link must NOT be connected to a BR323AL or BR323SS indicator when an explosive atmosphere is present.**

The BR323 electronic assembly may be removed from its enclosure for conditioning and calibration, or calibration may be performed in situ providing that an explosive atmosphere is not present.

### 6.1 Loading BEKA software onto a PC

The free BEKA configuration software may be downloaded from the BEKA associates web site at [www.beka.co.uk/indicate\\_flameproof.html](http://www.beka.co.uk/indicate_flameproof.html) or it is available on a CD. If required, please request a copy when ordering the instrument or contact the BEKA associates sales office.

A lead to connect a BR323 indicator to a serial communications port on a personal computer is available from BEKA associates.

The personal computer should have a Microsoft Windows 98, NT, 2000, XP or 7 operating system and the following hardware:

- Pentium processor or equivalent
- CD drive
- 8Mb of RAM minimum
- 20Mb hard disc space minimum
- RS232 or USB port - or see below

The BEKA configuration software should be downloaded from the BEKA web site or loaded from a CD onto the hard disc of a personal computer. To install the software, access the BEKAssetup.exe file and follow the screen prompts.

If an RS232 serial communications port is not available, a USB to RS232 converter with a male DB9 connector should be used. BEKA recommends the Chip-x10-Cable manufactured by Future Technology Devices International Ltd which can be purchased directly from <http://www.ftdichip.com/Products/Cables/USBRS232.htm> or is available from BEKA associates. Drivers for most operating systems are available free of charge from <http://www.ftdichip.com>.

### NOTE

**The USB communications port must be configured as COM 1, 2, 3 or 4.**

### 6.2 Connecting the BR323 indicator to a PC

Connect the supplied interconnecting cable between the programming plug on the front of the BR323 indicator and the COM port on the personal computer as shown in Fig 6. The BR323AL or BR323SS indicator must be connected to an adjustable 4/20mA signal during conditioning and calibration, this may be a 4/20mA calibrator or the indicator may remain in the measurement loop. The supplied serial connection cable does not provide isolation, we therefore recommend that either the 4/20mA loop or the personal computer is unearthed. Using a battery powered 4/20mA calibrator or a battery powered laptop computer will avoid earth loop problems.

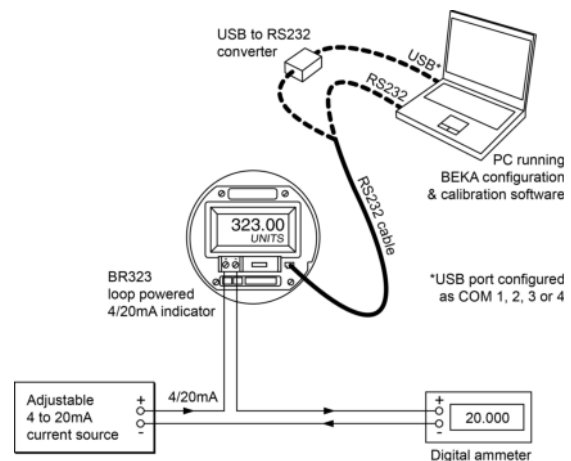

Fig 6 Connections for conditioning & calibrating a BR323

### 6.3 Calibration screen

To run the configuration software click *Program* in the PC *Start* menu and select *BEKA Associates; BR323 Configuration Program* followed by *BR323 Configuration Program*. The BEKA configuration software has an easy to use calibration screen that shows the status of the BR323 indicator and enables the required calibration parameters to be entered, as shown in Fig 7.

The left hand side of the screen shows the indicator serial number and its current conditioning and calibration. The right hand side of the screen is for entering new conditioning and calibration information and has two alternative tabs; *Input/Output* for linear calibration and *Custom Curve* for non-linear calibration such as a square root extracting curve. With the BR323 indicator connected as shown in Fig 6 the *Connection* panel at the lower left hand side of the screen will show when the PC has established communication with the BR323 indicator.

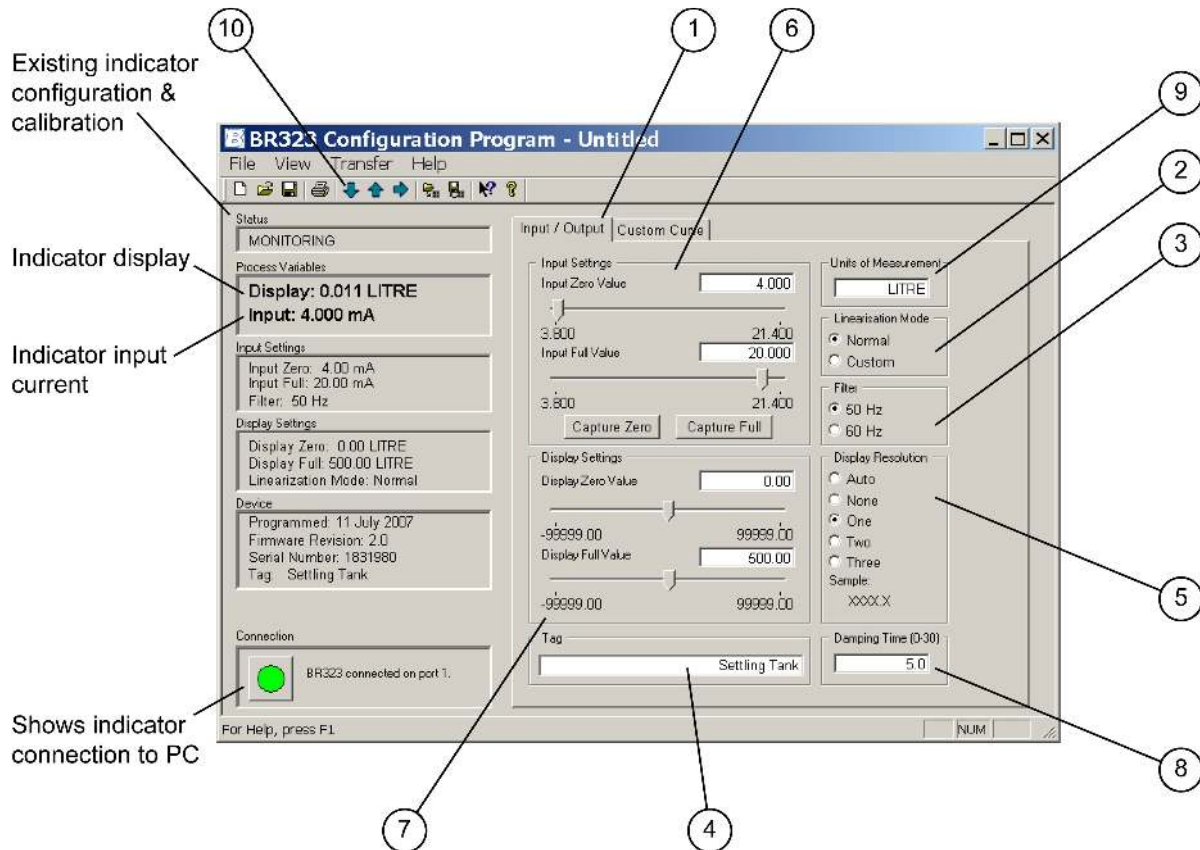

Fig 7 BEKA Configuration Programme Screen

#### 6.4 Linear calibration

With the indicator connected to the PC as shown in Fig 6 and communication established, proceed as follows:

##### (1) Right hand side tab

Click the *Input / Output* tab which will produce the screen shown in Fig 7.

##### (2) Linearisation Mode

Set to *Normal* for linear calibration

##### (3) Filter

Select frequency of local mains supply to obtain the maximum interference rejection.

##### (4) Tag

Up to 16 upper and lower case alphanumeric characters may be entered to identify the instrument. This identification only appears on the Configuration Programme screen not on the instrument display.

##### (5) Display Resolution

Defines the number of digits displayed by the indicator after the decimal point. *None*, *One*, *Two* or *Three* digits may be selected, alternatively selecting *Auto* instructs the indicator to display the maximum number of digits possible after the decimal point which will vary as the indicator display changes.

**Note:** Display Resolution does not affect the Configuration Programme Screen that always shows a fixed number of digits after the decimal point.

##### (6) Input Settings panel

Defines the input current at which the zero value display and the full value display are defined which is normally 4 and 20mA. These figures may be typed into the relevant boxes or clicking the *Capture Zero* or *Capture Full* buttons will automatically enter the current actually flowing into the indicator input terminals. This feature is useful when a complete loop is being calibrated.



### (7) Display Settings panel

Defines the indicator display at zero value and full value input current, which is normally 4 and 20mA.

**Note:** Irrespective of the selected Display Resolution, this panel always shows two digits after the decimal point.

### (8) Damping Time

A damping time between 0 and 30 seconds may be typed into this box. A long damping time will help to provide a steady display from a noisy input current.

### (9) Units of measurement

The *Units of Measurement* panel enables a five digit upper case alphanumeric legend to be entered which appears below the main indicator display. This may be used to show the instrument's units of measurement or application.

### (10) Downloading calibration to indicator

Ensure that the connection panel shows that the BR323 indicator is connected to the personal computer, then click the download arrow on the toolbar.

After downloading is complete the left hand side of the Configuration Programme screen should show the new calibration information and the BR323 should have the required display. The calibration information may be stored or printed from the PC in the normal way.

## 6.5 Non-linear calibration

The BEKA configuration software enables non-linear functions to be downloaded to a BR323 indicator. Any curve that continuously increases or decreases with between 2 and 128 breakpoints may be used.

## 6.6 Square root extraction

Probably the most common non-linear function is a square root curve that enables a BR323 indicator to display flow in linear engineering units. A square root table is included with the BEKA configuration software. To import the square root table proceed as follows:

### (1) Linearisation mode

Open the BEKA configuration programme and set the Linearisation Mode to *Custom* which will produce the screen shown in Fig 8.

### (2) Import file

Click *File* on the toolbar followed by *Import Custom Curve*. In the *C:\My BEKA Associates Data\Custom Curves* folder select *SquareRoot 0-100PCT.csv*. Click the *Open* button and the BEKA configuration software will import the square root file. The table of 128 x and y values will be displayed and the graph will show the square root curve.

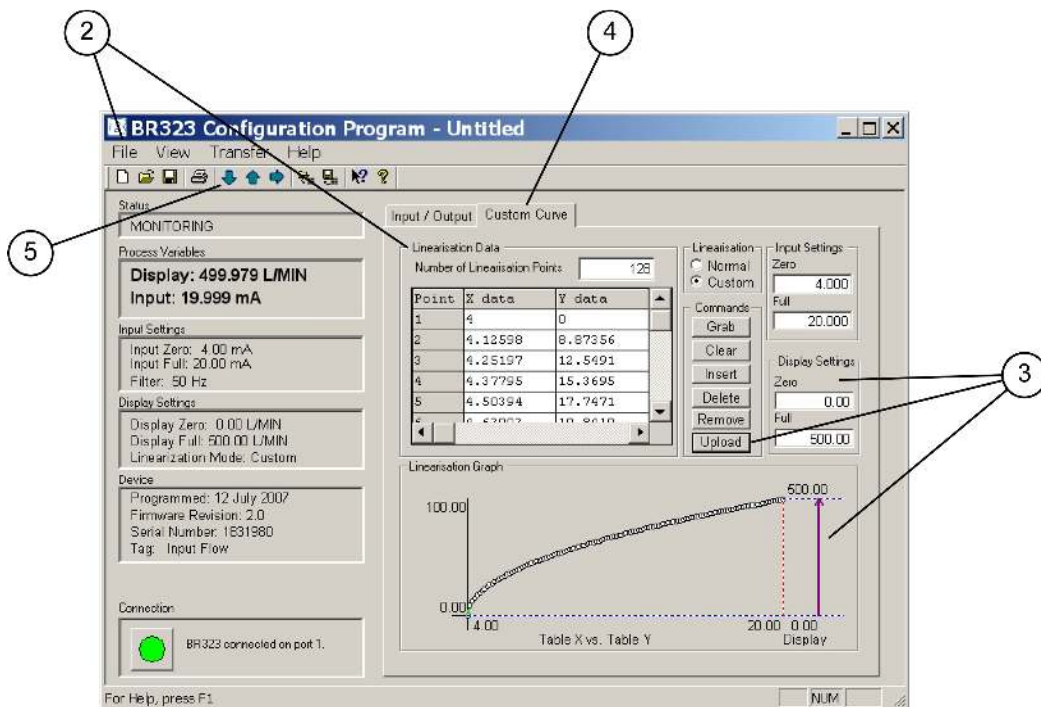

Fig 8 Non-linear BEKA Configuration Programme display screen

**(3) Enter the required indicator display**

Type the required BR323 indicator Zero and Full scale displays into the appropriate panels. Clicking the *Upload* button will enter these figures and they will appear on the graph.

**(4) Entering other parameters**

Clicking the *Input / Output* tab will enable the Filter, Tag, Display Resolution, Damping Time and Units of Measurement to be entered – see 6.4 steps 3, 4, 5, 6 & 9 and Fig 7.

**(5) Downloading calibration to indicator**

Ensure that the *Connection* panel shows that the BR323 indicator is connected to the personal computer then click the download arrow on the toolbar.

After downloading is complete the left hand side of the Configuration Programme Screen should show the new calibration information and the BR323 should have the required display. The calibration information may be stored or printed from the PC in the normal way.

**6.7 Other non-linear curves**

Other non-linear curves may be generated by entering the number of breakpoints required and manually keying the required x and y values into the table. Alternatively, a comma delimited csv file containing the custom curve data may be imported using the procedure described in section 6.6.

## 7. MAINTENANCE

### 7.1 Fault finding during commissioning

If a BR323AL or BR323SS fails to function during commissioning the following procedure should be followed:

Symptom	Cause	Solution
No display	Incorrect wiring	There should be 2.3V between the +ve & -ve terminals.
No display and no volts between +ve & -ve terminals.	Incorrect wiring or no power supply.	Check that a current is flowing in the loop.
	Insufficient loop voltage to operate indicator	Check supply voltage and voltage drops caused by all components in the loop
Indicator displays Hi	Positive over-range	The input current is greater than 21.4mA.
Indicator displays Lo	Negative under-range	The input current is less than 3.8mA.
Unstable display	4/20mA input has a large ripple content.	Ensure loop supply voltage is sufficient to operate the Indicator.
		Ensure that Filter is set to frequency of local mains supply.
		Increase indicator damping time.

### 7.2 Fault finding after commissioning

#### **ENSURE PLANT SAFETY BEFORE STARTING MAINTENANCE**

**Live maintenance is NOT permitted on flameproof equipment. BR323AL and BR323SS indicator maintenance should only be performed in a potentially hazardous area when an explosive atmosphere is not present.**

If a BR323AL or BR323SS fails after it has been functioning correctly, the following procedure should be followed:

Symptom	Cause	Solution
No display and no volts between +ve & -ve terminals.	No power supply	Check that a current is flowing in the loop.
Unstable display	4/20mA input has a large ripple.	Check loop supply voltage.
		Ensure that Filter is set to frequency of local mains supply.
		Increase indicator damping.

If this procedure does not reveal the cause of the fault, it is recommended that the BR323 electronic assembly is replaced.

**Note:** while the BR323 electronic assembly is disconnected the 4/20mA loop will be open circuit.

### 7.3 Servicing

All standard BR323 electronic assemblies are interchangeable, and a single spare may be used to replace any instrument that fails.

We recommend that faulty BR323 electronic assemblies are returned to BEKA associates or to our local agent for repair.

### 7.4 Routine maintenance

The mechanical condition of the instrument and the electrical calibration should be regularly checked. The interval between inspections depends upon environmental conditions. We recommend that initially instrument calibration should be checked annually.

### **7.5 Guarantee**

Indicators which fail within the guarantee period should be returned to BEKA associates or our local agent. It is helpful if a brief description of the fault symptoms is provided.

### **7.6 Customer comments**

BEKA associates is always pleased to receive comments from customers about our products and services. All communications are acknowledged and whenever possible, suggestions are implemented.

## **8. ACCESSORIES**

### **8.1 Pipe mounting kit**

The pipe mounting kit comprises a stainless steel 'U' bolt that enables the BR323AL and BR323SS indicators to be mounted onto any pipe with an outside diameter up to 50mm.

### **8.2 Tag strip**

The BR323AL and BR323SS can be supplied with tag or applicational information thermally printed onto a polyester strip secured to the instrument mounting bracket.

The following can be accommodated:

1 row of 36 alphanumeric characters  
1.8mm high.

and

1 row of 18 alphanumeric characters  
2.6mm high.

### **8.3 Tag plate**

The BR323AL and BR323SS can be supplied with a tie-on stainless steel plate etched with customer specified tag number or application information.

The following can be typically accommodated:

1 row of 7 alphanumeric characters  
11mm high.

or 1 row of 11 alphanumeric characters  
7mm high.

or 2 rows of 15 alphanumeric characters  
5mm high.