

1. DESCRIPTION

The BA504G, BA504G-SS, BA524G and the BA524G-SS are field mounting general purpose digital indicators that display the current flowing in a 4/20mA loop in engineering units. They are loop powered, but only introduce a 1.2V drop into the loop.

All the models are electrically similar, but have different size displays and enclosure materials.

BA504G	4 digits 34mm high GRP enclosure
BA504G-SS	4 digits 34mm high 316 stainless steel enclosure
BA524G	5 digits 29mm high + 31 segment bargraph GRP enclosure.
BA524G-SS	5 digits 29mm high + 31 segment bargraph 316 stainless steel enclosure

This abbreviated instruction sheet is intended to assist with installation and commissioning, a comprehensive instruction manual describing system design and calibration is available from the BEKA sales office or may be downloaded from our website.

2. INSTALLATION

The BA504G and BA524G have a robust glass reinforced polyester (GRP), carbon loaded enclosure. The BA504G-SS and the BA524G-SS have a 316 stainless steel enclosure. Both types of enclosure are impact resistant and provide IP66 ingress protection. They are suitable for exterior surface mounting in most industrial environments, or may be panel or pipe mounted using an accessory kit.

If the indicator is not bolted to an earthed post of structure the earth terminal should be connected to local earthed metal work or to the plant's potential equalising conductor. GRP indicators have an earth terminal on the cable entry bonding plate and stainless steel indicators in the bottom left hand corner of the back-box.

Terminals 8, 9, 10, 11, 12, 13 & 14 are only fitted when the indicator includes optional alarms and a backlight. See full manual for details.

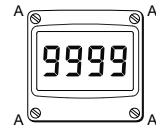

Step A
Unscrew the four captive 'A' screws and separate the indicator assembly and the back-box.

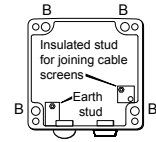

Step B
Secure the enclosure back-box to a flat surface with M6 screws through the four 'B' holes. Alternatively use a pipe mounting kit.

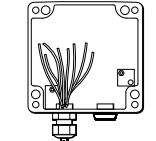

Step C
Remove the temporary hole plug and install an appropriate IP rated cable gland or conduit fitting. Feed the field wiring through the cable entry.

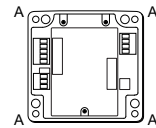

Step D
Terminate field wiring on the indicator assembly. Replace the indicator assembly on the enclosure back-box and tighten the four 'A' screws.

Fig 1 Installation procedure

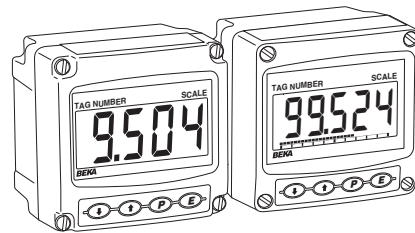
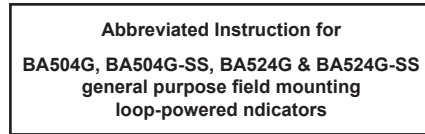

Issue 5
9th April 2021

BEKA associates Ltd. Old Charlton Rd, Hitchin, Hertfordshire, SG5 2DA, UK
Tel: +44(0)1462 438301 Fax: +44(0)1462 453971
e-mail: sales@beka.co.uk web: www.beka.co.uk

All models are CE marked to show compliance with the European EMC Directive 2004/108/EC.

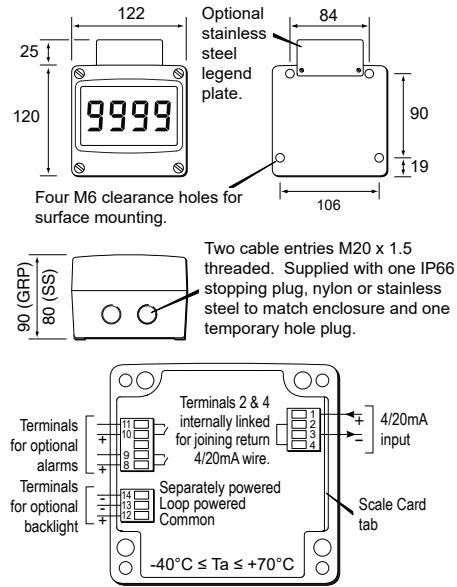

Fig 2 Dimensions and terminal connections

EMC

For specified immunity all wiring should be in screened twisted pairs, with the screens earthed at a common point.

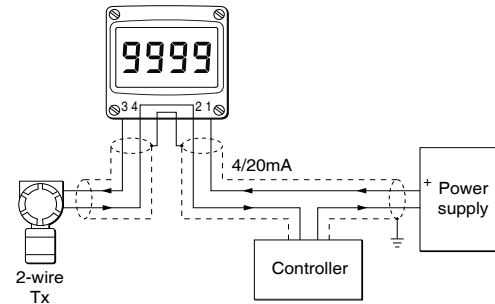

Fig 3 Typical measurement loop

Scale card

The indicator's units of measurement and tag information are shown above the display on a slide-in scale card. New instruments are fitted with a scale card showing the information requested when the instrument was ordered, if this is not provided a blank scale card will be fitted which can easily be marked on-site. Custom printed scale cards are available from BEKA associates.

To remove the scale card, carefully pull the tab perpendicularly away from the rear of the indicator assembly. See Fig 2 for the location of the scale card tab.

To replace the scale card carefully insert it into the slot on the right hand side of the input terminals which is shown in Fig 2. Force should be applied evenly to both sides of the scale card to prevent it twisting. The card should be inserted until about 2mm of the transparent tab remains protruding.

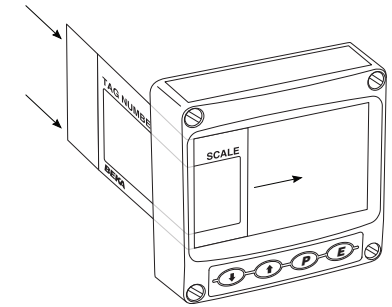

Fig 4 Inserting scale card into the instrument assembly.

3. OPERATION

Both models are controlled and calibrated via four front panel push buttons. In the display mode i.e. when the indicator is displaying a process variable, these push buttons have the following functions:

- [P]** While this button is pushed the indicator will display the input current in mA, or as a percentage of the instrument span depending upon how the indicator has been configured. When the button is released the normal display in engineering units will return. The function of this push button is modified when optional alarms are fitted to the indicator.
- [V]** While this button is pushed the indicator will display the numerical value and analogue bargraph* the indicator has been calibrated to display with a 4mAΦ input. When released the normal display in engineering units will return.
- [A]** While this button is pushed the indicator will display the numerical value and analogue bargraph* the indicator has been calibrated to display with a 20mAΦ input. When released the normal display in engineering units will return.
- [E]** No function in the display mode unless the tare function is being used.
- [P] + [V]** Indicator displays firmware number followed by version.
- [P] + [A]** Provides direct access to the alarm setpoints when the indicator is fitted with optional alarms and the RCLSP access setpoints function has been enabled.
- [P] + [E]** Provides access to the configuration menu via optional security code.



Note * BA524G & BA524G-SS only
Φ If the indicator has been calibrated using the CAL function, calibration points may not be 4 and 20mA.

4. CONFIGURATION

Indicators are supplied calibrated as requested when ordered, if not specified default configuration will be supplied but can easily be changed on-site.

Fig 5 shows the location of each function within the configuration menu with a brief summary of the function. Please refer to the full instruction manual for detailed configuration information and for a description of the lineariser and the optional dual alarms.

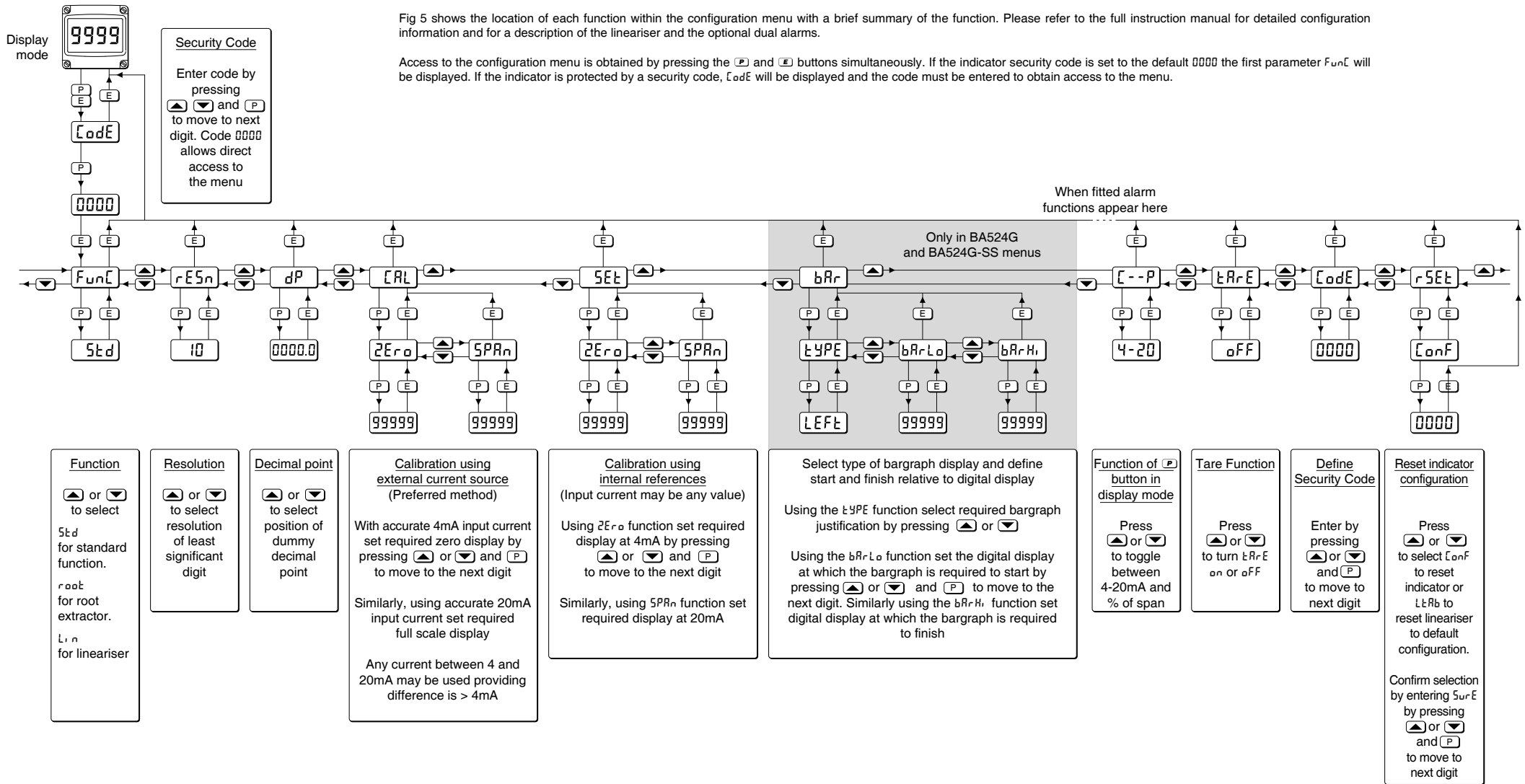
Access to the configuration menu is obtained by pressing the **[P]** and **[E]** buttons simultaneously. If the indicator security code is set to the default 0000 the first parameter **Func** will be displayed. If the indicator is protected by a security code, **Code** will be displayed and the code must be entered to obtain access to the menu.

Manuals and datasheets can be downloaded from <http://www.beka.co.uk/lpi4/>

Fig 5 Configuration menu