

BA384G and BA384E
Intrinsically safe
Two input
Rate Totaliser
Issue 5

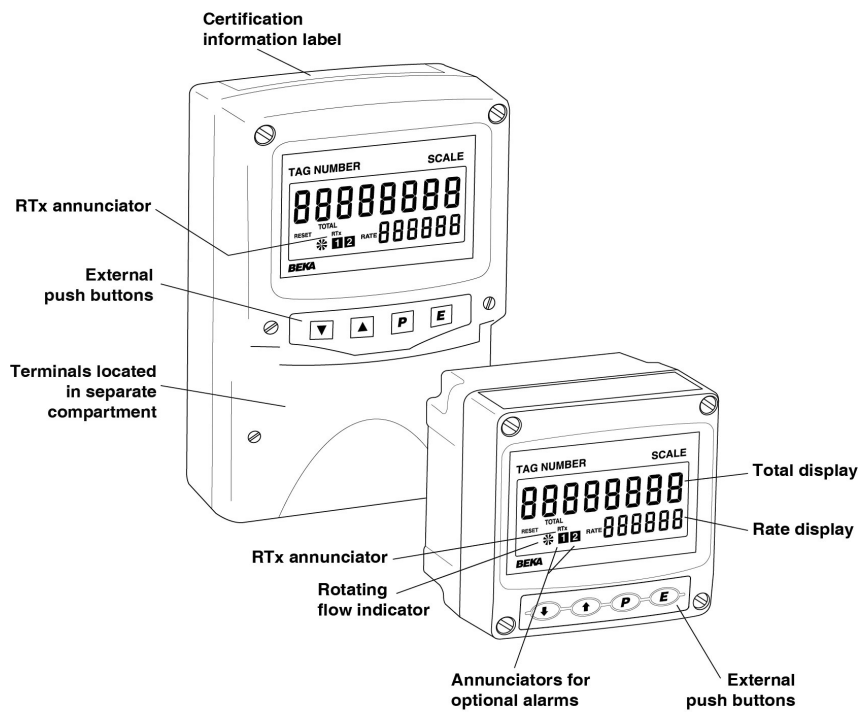

CONTENTS

- 1. DESCRIPTION**
- 2. OPERATION**
 - 2.1 Initialisation
 - 2.2 Controls
 - 2.3 Displays
 - 2.3.1 Display over-range
- 3. INTRINSIC SAFETY CERTIFICATION**
 - 3.1 ATEX gas certification
 - 3.2 Zones, gas groups & T rating
 - 3.3 Special conditions for safe use
 - 3.4 Power supply
 - 3.5 Pulse input terminals
 - 3.5.1 Flowmeters that do not require energising.
 - 3.5.2 Flowmeters that do require energising.
 - 3.6 Remote reset terminals
 - 3.7 Certification label information
- 4. SYSTEM DESIGN FOR HAZARDOUS AREAS**
 - 4.1 Use with Zener barriers**
 - 4.1.1 Power supply
 - 4.1.2 Pulse inputs
 - 4.1.3 Switch contact input
 - 4.1.4 Open collector input
 - 4.1.5 2-wire proximity detector input
 - 4.1.6 Magnetic pick-off input
 - 4.1.7 Voltage pulse input
 - 4.1.8 Remote reset
 - 4.2 Use with galvanic isolators**
 - 4.2.1 Power supply
 - 4.2.2 Pulse inputs
 - 4.2.3 Switch contact input
 - 4.2.4 Open collector input
 - 4.2.5 2-wire proximity detector input
 - 4.2.6 Magnetic pick-off input
 - 4.2.7 Voltage pulse input
 - 4.2.8 Remote reset
- 5. INSTALLATION**
 - 5.1 Location
 - 5.2 Installation procedure
 - 5.3 EMC
 - 5.4 Units of measurement and tag marking on scale card.
- 6. CONFIGURATION AND CALIBRATION**
 - 6.1 Calibration structure
 - 6.2 Accessing configuration functions
 - 6.3 Summary of configuration functions
 - 6.4 Rate totaliser function: $F_{\text{unEt, on}}$
 - 6.5 Input: i_{nPulse}
 - 6.6 Input type: $i_{\text{nPulseYPE}}$
 - 6.7 Debounce: $dEbounCE$
 - 6.8 Display update interval: $uPdREtE$
 - 6.9 Count: C_{ount}
 - 6.10 Upper display: $d_i SP-1$
 - 6.11 Lower display: $d_i SP-2$
 - 6.12 Position of decimal points: dP
 - 6.13 Flowmeter K-factor: $FRLEt-R$
 - 6.14 Total scale factor: $SRLEt-R$
 - 6.15 Rate scale factor: $SRLEr-R$
 - 6.16 Timebase: $t-bRSE$
 - 6.17 Display filter: $F_i LLEr-R$
 - 6.18 Clip-off: $CLPoff-R$
 - 6.19 Local reset: $Lr CLr$
 - 6.20 Local total reset: $CLt Et$
 - 6.21 Local grand total reset: $CLr GEt$
 - 6.22 External reset: $E CLr$
 - 6.23 Grand total reset from configuration menu: $CLr-GEt$
 - 6.24 Define security code: $CodE$
 - 6.25 Reset to factory defaults: $rSEt dEF$
- 7. LINEARISERS**
 - 7.1 Flowmeter specification
 - 7.2 Summary of lineariser configuration functions.
 - 7.3 Copy A lineariser to b lineariser: $COPY R2b$
 - 7.4 Add a segment: Rdd
 - 7.5 Remove a segment: dEL
 - 7.6 Input frequency: $PULSE Fr$
 - 7.7 Flowmeter K-factors: $L-FRLEt-R$
 - 7.8 Lineariser error messages
 - 7.9 Lineariser factory defaults
- 8. Pulse Output**
 - 8.1 Intrinsic safety
 - 8.2 System design
 - 8.3 Configuration
 - 8.4 Access pulse output sub-menu
 - 8.5 Enable pulse output: $EnbL$
 - 8.6 Source of output pulse: $SourceEE$
 - 8.7 Divide output pulse frequency: $d_i U_i dE$
 - 8.8 Define output pulse width: $dUrREt, on$
 - 8.9 Stored pulses

9. CONFIGURATION EXAMPLE

9.1 Configuration procedure

10. MAINTENANCE

- 10.1 Fault finding during commissioning
- 10.2 Fault finding after commissioning
- 10.3 Servicing
- 10.4 Routine maintenance
- 10.5 Guarantee
- 10.6 Customer comments

11. ACCESSORIES

- 11.1 Units of measurement and instrument identification.

11.2 Backlight

11.3 Alarms

- 11.3.1 Solid state output
- 11.3.2 Intrinsic safety
- 11.3.3 Configuration & adjustment
- 11.3.4 Alarm enable: `ENBL`
- 11.3.5 Type of alarm: `TYPE`
- 11.3.6 Setpoint adjustment: `SP LR-R`
- 11.3.7 Alarm function: `HiLo`
- 11.3.8 Alarm output status: `nonE`
- 11.3.9 Hysteresis: `H5Er`
- 11.3.10 Alarm delay: `dELR`
- 11.3.11 Alarm silence time: `SrL`
- 11.3.12 Flash display: `FL5H`
- 11.3.13 Access setpoints: `RE5P`
- 11.3.14 Adjusting alarm setpoints from totalising mode.

11.4 4/20mA output

- 11.4.1 Intrinsic safety
- 11.4.2 System design
- 11.4.3 Configuration
- 11.4.4 Access 4/20mA output sub-menu: `4-20 oP`
- 11.4.5 Enable 4/20mA output: `ENBL`
- 11.4.6 Select rate or total source: `4-20tYPE`
- 11.4.7 Display which corresponds to 4mA output: `4000`
- 11.4.8 Display which corresponds to 20mA output: `20000`

Appendix 1

Dust certification

Appendix 2

IECEX certification

Appendix 3

ETL and cETL certification

Appendix 4

BA384E Rate Totaliser

1. DESCRIPTION

These intrinsically safe, two input rate totalisers are primarily intended for use with two pulse output flowmeters. The BA384G and the BA384E are functionally identical and have similar certifications, but differ in mechanical construction and options.

The differences are summarised in the following table.

	BA384G	BA384E
Separate terminal compartment.	No	Yes
Pulse output	Yes	Yes
Backlight	Option	Yes
4/20mA output.	Option	Yes
Dual alarms	Option	Yes
Certification		
IECEX	Gas & dust	Gas
ATEX	Gas & dust	Gas
ETL & cETL	Gas & dust	Gas & dust

The main sections of this instruction manual describe the BA384G, but they also apply to the BA384E. Details of the BA384E mounting and terminals are contained in Appendix 4.

The BA384G and BA384E have been ATEX certified intrinsically safe by Notified Body Intertek Testing and Certification Ltd and comply with the European ATEX Directive 2014/34/EU. The BA384G has gas and dust certification, but the BA384E only has ATEX gas certification.

The main sections of this manual describe ATEX gas certification.

For international applications the BA384G and BA384E also have IECEX certification which is described in Appendix 2. The BA384E does not have IECEX dust certification.

For applications in the USA and Canada the BA384G and BA384E have ETL & cETL certification which is described in Appendix 3.

The BA384G and BA384E simultaneously display the rate of flow and the total flow in the same or different engineering units. Either input, or their sum or difference may be shown. The instruments are controlled and configured via the four front panel push buttons, a user defined four digit code may be entered to prevent accidental access to the instrument's configuration menu.

This instruction manual supplements the abbreviated instruction sheet supplied with each instrument.

2. OPERATION

Fig 1 shows a simplified block diagram of the BA384G Rate Totaliser. The instrument has two separate inputs 'A' and 'b' which can accept pulses from two flowmeters and display the individual rates and totals, or the sum or difference of the two rates and totals.

Each input may be individually configured to accept pulses from a wide variety of flowmeter sensors and to display the rate of flow and the total flow in the same or different engineering units.

When the flowmeter sensors requires energising, such as a switch contact, open collector or a two wire proximity detector, an external link connected between terminals supplies power to the appropriate BA384G input terminals.

Each channel has a separate lineariser with up to sixteen straight-line segments that may be configured to compensate for the flowmeter's non-linearity.

The BA384G Rate Totaliser has an isolated pulse output which may be configured to synchronously retransmit either of the two pulse inputs, or a scaleable pulse when the least significant digit of total display is incremented.

The following factory fitted accessories are available:

Internally powered display backlight

Dual isolated alarm outputs

Isolated 4/20mA current sink output

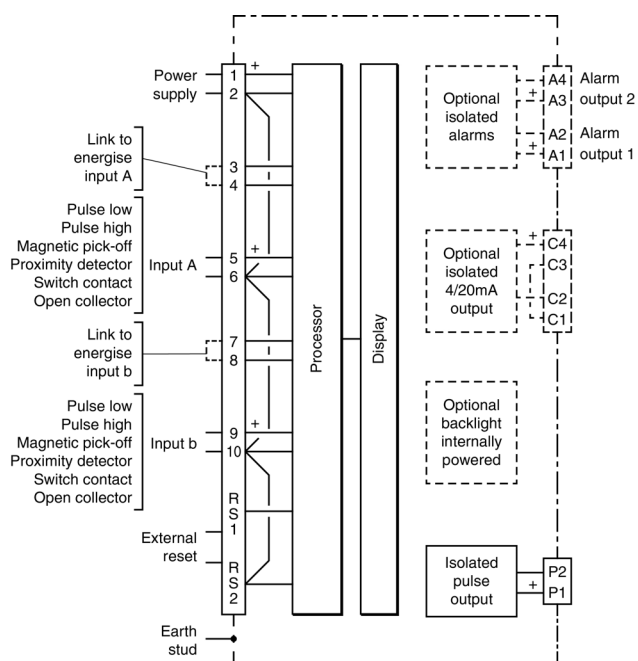

Fig 1 BA384G rate totaliser block diagram

2.1 Initialisation

Each time power is applied to a BA384G initialisation is performed. After a short delay the following display sequence occurs:

All segments of the display are activated

Rate Totaliser starts functioning using the configuration information stored in the instrument's permanent memory. Unless total and grand total displays have been reset to zero, any new flow will be added to the existing totals.

2.2 Controls

The BA384G is controlled and configured via four front panel push buttons. In the totalising mode i.e. when the instrument is displaying rate and total flow the push button functions are:

Push Button Functions

- ▼ or ▲ Scrolls both displays between:
Input A
Input b
Input A + b or Input A – b which is configurable. See 6.9
- ⓔ + ▼ Grand total - shows the least significant 8 digits of a 16 digit counter.
- ⓔ + ▲ Grand total - shows the most significant 8 digits of a 16 digit counter. If buttons are pressed for longer than 10 seconds the grand total will be reset to zero if the grand total reset function $\llcorner \llcorner \llcorner \llcorner$ is enabled. See 6.21
- To reset the grand total to zero from the operating mode press the ⓔ and ▲ buttons for ten seconds until $\llcorner \llcorner \llcorner \llcorner$ is displayed. Using the ▼ or ▲ button change the display to $\llcorner \llcorner \llcorner \llcorner$ and press ⓔ which will reset the grand total and restore the original display.
- ▼ + ▲ If the local total reset function $\llcorner \llcorner \llcorner \llcorner$ is enabled in the configuration menu, simultaneously pressing the ▼ and ▲ buttons for more than three seconds allows total A, total b or both totals to be selected by operating the ▼ or ▲ button. Operating the ⓔ button will then reset the selected total to zero and clear any stored output pulses. See 6.20
- ⓔ + ▼ Shows each for 2 seconds:
Firmware and version numbers
Function of instrument: $\llcorner \llcorner \llcorner \llcorner$
Options fitted:
-R Alarms
-L 4/20mA output
-P Pulse output (always fitted)
- ⓔ + ▲ Provides direct access to the alarm setpoints when the Rate Totaliser is fitted with optional alarms and the $\llcorner \llcorner \llcorner \llcorner$ setpoints function has been enabled.
- ⓔ + ⓔ Access to configuration menu

2.3 Displays

The BA384G has two digital displays and associated annunciators, plus a flow indicator as shown on the front cover of this manual.

Total display Shows the total flow of the selected input or the composite flow $A + b$ or $A - b$ usually on the upper eight digit display. May be reset to zero by the front panel push buttons or a remote reset switch.

Rate display Shows the flow rate of the selected input or the composite flow rate $A + b$ or $A - b$ usually on the lower six digit display.

Flow indicator This disc in the lower left hand corner of the instrument display 'rotates' for two seconds each time an input pulse is received on the input being displayed. Appears to rotate continuously when input frequency exceeds 0.5Hz.

Hold annunciator Activated when input frequency is below the clip-off threshold for the input being displayed.

Reset annunciator Activated while the instrument is being reset.

Rate annunciator Identifies the rate display

Total annunciator Identifies the total display

RTx annunciator Retransmitted pulse annunciator. Depends upon the setting of `5OUT[E]` in the pulse output configuration menu.

SCALE#

Annunciator activated each time pulse output open collector is *on*, i.e. Ron is less than $60\Omega + 3V$.

d, rEct:

Annunciator continuously activated.

2.3.1 Display over-range

Over-range of the upper eight digit display or the lower six digit display is indicated by all the digits displaying 9 and all the decimal points flashing.

3. INTRINSIC SAFETY CERTIFICATION

The BA384G has ATEX and IECEx gas and dust certification. This section of the instruction manual describes ATEX gas certification. ATEX dust and IECEx approvals are described in Appendixes 1 and 2.

3.1 ATEX gas certification

Notified Body Intertek Testing and Certification Ltd have issued the BA384G with an EU-Type Examination Certificate number ITS16ATEX28408X. This confirms compliance with harmonised European standards and it has been used to confirm compliance with the European ATEX Directive for Group II, Category 1G equipment, Ex ia IIC T5 Ga equipment. The Rate Totaliser carries the community mark and, subject to local codes of practice, may be installed in any of the European Economic Area (EEA) member countries. ATEX certificates are also acceptable for installations in Switzerland.

This section of the instruction manual describes ATEX installations in explosive gas atmospheres conforming with EN 60079-14 *Electrical installations design, selection and erection*. When designing systems for installation outside the UK the local Code of Practice should be consulted.

3.2 Zones, gas groups and T rating

The BA384G Rate Totaliser has been certified Ex ia IIC T5 Ga. When connected to a suitable system it may be installed in:

Zone 0	explosive gas air mixture continuously present.
Zone 1	explosive gas air mixture likely to occur in normal operation.
Zone 2	explosive gas air mixture not likely to occur, and if it does will only exist for a short time.

Be used with gases in groups:

Group	A	propane
Group	B	ethylene
Group	C	hydrogen

In gases that may be used with equipment having a temperature classification of:

T1	450°C
T2	300°C
T3	200°C
T4	135°C
T5	100°C

At ambient temperatures between -40 and +70°C.

3.3 Special conditions for safe use

CAUTION installation in Zone 0

When installed in a Zone 0 potentially explosive atmosphere requiring EPL Ga apparatus, the instrument shall be installed such that even in the event of rare incidents, an ignition source due to impact or friction between the aluminium label and iron/steel is excluded.

No special conditions apply when the BA384G Rate Totaliser is installed in Zone 1 or in Zone 2. This allows the BA384G to be installed in all gas Zones and to be used with most common industrial gases except carbon disulphide and ethyl nitrite which have an ignition temperature of 95°C.

3.4 Power supply

When installed in a hazardous area the BA384G should be powered from a certified Zener barrier, galvanic isolator or associated apparatus with an intrinsically safe voltage output.

The safety parameters of terminals 1 and 2 are:

U_i	=	28V dc
I_i	=	200mA dc
P_i	=	0.84W
U_o	=	0
I_o	=	0

Any certified Zener barrier, galvanic isolator or associated apparatus with output safety parameters equal to or less than these input limits may be used.

The maximum equivalent capacitance and inductance between terminals 1 and 2 is:

C_i	=	2nF
L_i	=	4μH

To determine the maximum permissible cable parameters the above figures, which are small and may be ignored in some applications, should be subtracted from the maximum permitted cable parameters specified for the Zener barrier, galvanic isolator or associated apparatus powering the BA384G Rate Totaliser.

3.5 Pulse input terminals

The BA384G Rate Totaliser has two pulse inputs, A and b, that may be individually configured for use with different types of flowmeter. Each input is a separate intrinsically safe circuit, although the negative side of each input is internally connected to the negative side of the power supply and the reset terminal RS2. See Fig 1. The two inputs should not be connected in parallel.

For flowmeters with sensors that require energising to determine their state, such as a switch contact, open collector or a 2-wire proximity detector in a turbine flowmeter, fitting an external link between terminals 3 & 4 of the BA384G for input A and between terminals 7 & 8 for input b, connects an internal 7V, 6mA supply to the respective input. Energising is not required when a BA384G input is connected to a voltage pulse source.

Fitting an energising link changes the output safety parameters of each BA384G input as shown in the following table which also shows the types of sensor requiring energising (link fitting).

Type of input	Output safety parameters of each input.			
	Link*	Uo	Io	Po
Switch contact	Yes	10.5V	9.2mA	24mW
Proximity detector	Yes	10.5V	9.2mA	24mW
Open collector	Yes	10.5V	9.2mA	24mW
Magnetic pick-off	No	1.1V	0.5µA	0.2mW
Voltage input (low)	No	1.1V	0.5mA	0.2mW
Voltage input (high)	No	1.1V	0.5mA	0.2mW

*For input A link terminals 3 and 4

*For input b link terminals 7 and 8

3.5.1 Flowmeters that don't require energising

Flowmeters employing magnetic pick-offs and voltage pulse sensors do not require energising, therefore terminals 3 & 4 for input A and terminals 7 & 8 for input b should not be linked. When not energised i.e. without a link, each BA384G input complies with the requirements for *simple apparatus*. For intrinsic safety purposes, sources of energy with output parameters less than 1.5V; 100mA and 25mW are considered to be *simple apparatus* (Clause 5.7 of EN60079-11), which allows their output parameters Uo, Io & Po to be ignored when assessing the safety of an intrinsically safe system, thus simplifying loop assessment and documentation.

Almost any flowmeter with a voltage pulse output may be directly connected to one of the BA384G inputs in a hazardous area providing that:

- The flowmeter is a certified intrinsically safe device having output parameters equal to or less than:

$$\begin{aligned} U_o &\leq 28\text{V dc} \\ I_o &\leq 200\text{mA dc} \\ P_o &\leq 0.84\text{W} \end{aligned}$$

or complies with requirements for *simple apparatus*.

- The flowmeter and associated wiring can withstand a 500V rms insulation test to earth.
- The flowmeter is located in the same hazardous area as the BA384G.

The BA384G EU-Type Examination Certificate specifies that the equivalent capacitance and inductance of each BA384G input is:

$$\begin{aligned} C_i &= 2\text{nF} \\ L_i &= 4\mu\text{H} \end{aligned}$$

To determine the maximum permissible cable parameters these figures should be subtracted from the maximum permitted output parameters Io and Co specified by the certificate for the flowmeter connected to the BA384G input terminals. The BA384G input parameters are small and therefore unlikely to make a significant difference to the allowable cable parameters.

3.5.2 Flowmeters that require energising

Flowmeters with switch contacts, proximity detector or open collector outputs require energising which is achieved by linking two BA384G terminals together for each input as described in section 3.5. When energised, the output parameters of each BA384G Rate Totaliser input are:

$$\begin{aligned} U_o &= 10.5\text{V dc} \\ I_o &= 9.2\text{mA dc} \\ P_o &= 24\text{mW} \end{aligned}$$

These output parameters do not comply with the requirements for *simple apparatus* and should be considered when assessing the safety of the flowmeter connected to a BA384G input.

Any certified intrinsically safe flowmeter may be connected to a BA384G energised input providing that:

- a. The flowmeter is a certified intrinsically safe device having input parameters equal to or greater than:

$$\begin{aligned} U_i &\geq 10.5V \text{ dc} \\ I_i &\geq 9.2\text{mA dc} \\ P_i &\geq 24\text{mW} \end{aligned}$$

or complies with the requirements for *simple apparatus* such as switch contacts.

- b. The flowmeter and associated wiring can withstand a 500V rms insulation test to earth.
- c. The flowmeter is located in the same hazardous area as the BA384G.
- d. Minimum operating voltage of flowmeter incorporating a proximity detector should be less than 7.5V.

The maximum capacitance and inductance that may be safely connected to each energised input (link connected) is:

$$\begin{aligned} C_o &= 2.4\mu\text{F} \\ L_o &= 200\text{mH} \end{aligned}$$

This is not restrictive as the combined capacitance and inductance of most sensors and connecting cable will be less than this.

3.6 Remote reset terminals

The BA384G total display may be reset to zero by connecting the external reset terminals RS1 and RS2 together for more than one second. The two reset terminals have the following input and output safety parameters:

$$\begin{aligned} U_o &= 3.8V \text{ dc} \\ I_o &= 1\text{mA dc} \\ P_o &= 1\text{mW} \end{aligned}$$

$$\begin{aligned} U_i &= 28V \text{ dc} \\ I_i &= 200\text{mA dc} \\ P_i &= 0.84\text{W} \end{aligned}$$

The equivalent capacitance and inductance between them is:



$$\begin{aligned} C_i &= 0\text{nF} \\ L_i &= 0\mu\text{H} \end{aligned}$$

The maximum cable capacitance and inductance that may be safely connected between the reset terminals RS1 and RS2 is:

$$\begin{aligned} C_o &= 40\mu\text{F} \\ L_o &= 1\text{H} \end{aligned}$$

The reset terminals may be directly connected to any mechanically operated switch located within the same hazardous area as the BA384G. The switch and associated wiring should be able to withstand a 500V rms insulation test to earth.

If the reset switch is required in the safe area a Zener barrier or intrinsically safe relay is required to transfer the contact closure into the hazardous area. Almost any intrinsically safe relay with certification permitting the contacts to be connected to equipment in the hazardous area may be used. A positive polarity Zener barrier may also be used as shown in Fig 2. A diode return barrier is not suitable for this application.

The BA384G may also be configured so that the total display is reset to zero when the  and  push buttons are operated simultaneously for more than three seconds. See 6.20

3.7 Certification label information

The BA384G product certification label is fitted in a recess on the top outer surface of the instrument enclosure. It shows the ATEX and IECEx certification information plus BEKA associates name and location and the instrument serial number. Certification information from other authorities may also be included.

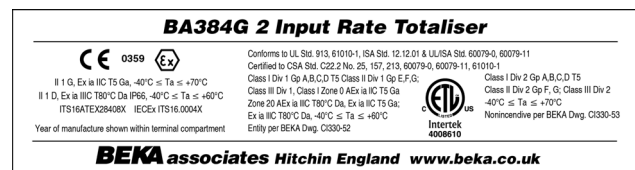

BA384G Certification information label

4. SYSTEM DESIGN FOR HAZARDOUS AREAS.

For simplicity the pulse output is described separately in section 8 and the optional alarms and 4/20mA output in section 11 of this manual.

4.1 Use with Zener barriers

Zener barriers are the least expensive intrinsically safe interface between a safe and hazardous area. However, they require a high integrity earth connection that may be expensive to install and they do not provide isolation. When a high integrity earth connection is not already available, it may be less expensive and complicated to use galvanic isolators for the installation of a single BA384G.

Terminals 2, 6, 10 and RS2 of the BA384G Rate Totaliser are internally connected together as shown in Fig 1. If any of these terminals are earthed, as shown in Figs 2 & 3, the other common terminals should only be connected to the same earth, i.e. the barrier busbar, or to circuits that have at least 500V insulation to earth.

Any Zener barrier certified for the gas group in which the BA384G is installed may be used providing the output parameters do not exceed the input parameters of the BA384G terminals to which it is connected. Only one polarity of Zener barrier i.e. positive or negative may be used in each system.

Fig 2 illustrates the basic circuit that is used for all BA384G Rate Totaliser installations protected by Zener barriers. For simplicity the pulse output and the optional alarm and 4/20mA outputs are described separately in sections 8 and 11 of this manual.

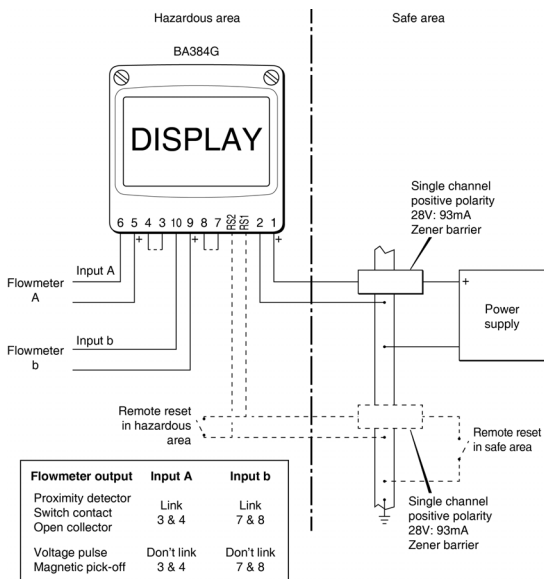

Fig 2 BA384G used with Zener barriers

The flowmeters may also be located in the safe area. Fig 3 shows how additional Zener barriers are used to transfer signals to the Rate Totaliser in the hazardous area. When more than one Zener barrier is used in a system all must have the same polarity. i.e. all positive or all negative barriers.

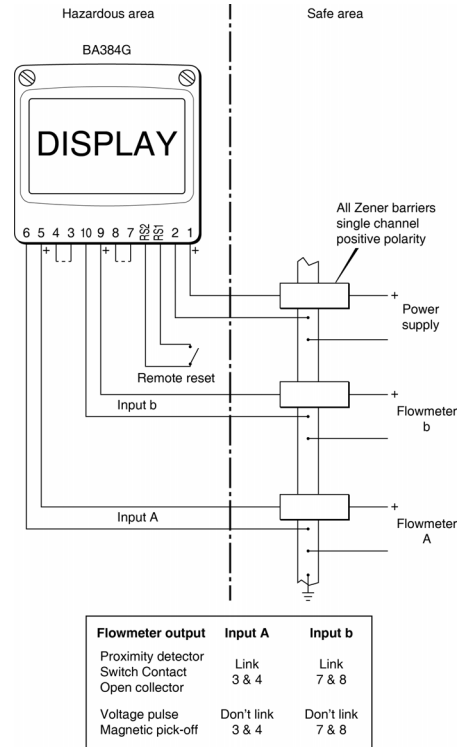

Fig 3 BA384G used with Zener barriers flowmeters in the safe area.

4.1.1 Power supply

The BA384G Rate Totaliser requires a minimum of 10V between terminal 1 & 2 and consumes:

- 10mA without optional backlight
- plus 6mA when terminals 3 & 4 are linked
- plus 6mA when terminals 7 & 8 are linked
- plus 16mA with optional backlight

Any Zener barrier certified for the gas group in which the BA384G is installed may be used to power the instrument providing the output safety parameters of the barrier are equal to or less than the input safety parameters of terminals 1 & 2.

Although this allows a wide variety of barriers to be used, a positive polarity 28V; 93mA; 300Ω Zener barrier, which has an end-to-end resistance of about 340Ω, is an industry standard device which is frequently used. With this barrier the supply voltage in the safe area must be between the minimum value shown below and the maximum working voltage of the Zener barrier which, depending upon manufacturer, will be approximately 26V.

	13.5V min	without optional backlight
	18.9V min	with optional backlight
plus	2.1V	when terminals 3 & 4 are linked
plus	2.1V	when terminals 7 & 8 are linked

4.1.2 Pulse inputs

As shown in Fig 2 both BA384G Rate Totaliser inputs may be connected to hazardous area flowmeters with a wide variety of outputs, or to safe area flowmeters as shown in Fig 3.

No Zener barrier is required in series with each input if the intrinsically safe flowmeter is located within the same hazardous area as the BA384G. The following table shows the Rate Totaliser's input switching thresholds when configured to operate with various sensors. For reliable operation input pulses must fall below the lower threshold and rise above the upper threshold.

Flowmeter output	Switching thresholds	
	Lower	Upper
Switch contacts	100Ω	1000Ω
Proximity detector	1.2mA	2.1mA
Open collector	2kΩ	10kΩ
Magnetic pick-off	0mV	40mV peak
Voltage pulse low	1.0V	3.0V
Voltage pulse high	3.0V	10.0V

Flowmeters with a switch contact, proximity detector or an open collector output require energising which is achieved by linking two BA384G terminals together for each input as shown in Figs 2 & 3.

4.1.3 Switch contact input

Any flowmeter with a mechanically or magnetically activated switch contact output may be directly connected to input terminals 5 & 6 or 9 & 10. The flowmeter should be located in the same hazardous area as the BA384G, and the flowmeter and associated wiring should be able to withstand a 500V rms insulation test to earth. Most magnetically activated reed relays used in turbine flowmeters comply with these requirements. The BA384G contains a configurable debounce circuit to prevent contact bounce being counted. Three levels of debounce protection are independently available for each input. See section 6.7.

4.1.4 Open collector input

Certified intrinsically safe flowmeters with an open collector output may be directly connected to input terminals 5 & 6 or 9 & 10 providing the flowmeter is located in the same hazardous area as the BA384G, and the flowmeter and associated wiring can withstand a 500V rms insulation test to earth.

The BA384G contains a configurable debounce circuit to prevent false triggering. Three levels of debounce protection are independently available for each input. See section 6.7.

4.1.5 2-wire proximity detector input

Most certified intrinsically safe flowmeters incorporating a NAMUR 2-wire proximity detector may be directly connected to a BA384G input, providing the input safety parameters of the flowmeter (proximity detector) are equal to or greater than the output safety parameters of a BA384G input. i.e.

U_i	\geq	10.5V dc
I_i	\geq	9.2mA dc
P_i	\geq	24mW

and the minimum operating voltage of the flowmeter (proximity detector) is less than 7.5V. The flowmeter must be located in the same hazardous area as the BA384G and with the associated wiring be able to withstand a 500V rms insulation test to earth.

The BA384G contains a configurable de-bounce circuit to prevent false triggering. Three levels of debounce protection are independently available for each input. See section 6.7.

4.1.6 Magnetic pick-off input

Flowmeters incorporating a magnetic pick-off to sense flow will have a low level voltage output unless the flowmeter incorporates an amplifier. [0, L in the BA384G input configuration menu is a low level voltage pulse input intended for use with an intrinsically safe magnetic pick-off. When a BA384G input is configured for [0, L it complies with the requirements for *simple apparatus* allowing connection to any certified intrinsically safe magnetic sensor having output parameters equal to or less than:

U_o	\leq	28V dc
I_o	\leq	200mA dc
P_o	\leq	0.84W

The maximum permitted cable parameters will be the magnetic pick-off's C_o and L_o specified on its intrinsic safety certificate, less the BA384G input parameters C_i and L_i which are small and can often be ignored.

The flowmeter must be located within the same hazardous area as the BA384G and with the associated wiring be able to withstand a 500V rms insulation test to earth.

The BA384G contains a configurable debounce circuit to prevent false triggering of the instrument. See section 6.7.

4.1.7 Voltage pulse input

Two voltage pulse input ranges are independently selectable in the BA384G Rate Totaliser configuration menu, *UoLk5 L* and *UoLk5 H*. When configured for either of the voltage pulse ranges, the input terminals 5 & 6 and 9 & 10 comply with the requirements for *simple apparatus*. This allows the inputs to be connected to any certified intrinsically safe voltage source within the same hazardous area as the BA384G having output parameters equal to or less than:

U_o	\leq	28V dc
I_o	\leq	200mA dc
P_o	\leq	0.84W

The BA384G Rate Totaliser may therefore be directly connected to most certified intrinsically safe flowmeters with a high level voltage pulse output.



The maximum permitted cable parameters will be defined by the intrinsic safety certification of the flowmeter less the BA384G input parameters which are small and can often be ignored.

The BA384G contains a configurable debounce circuit to prevent false triggering of the instrument. Three levels of de-bounce protection are independently available for each input, See section 6.7.

4.1.8 Remote reset

The BA384G total display may be remotely reset to zero by connecting RS1 and RS2 together for more than one second. Permanent interconnection inhibits totalisation. Remote resetting may be accomplished by any mechanically operated switch located in the same hazardous area as the Rate Totaliser providing the switch and the associated wiring can withstand a 500V rms insulation test to earth. No Zener barrier is required.

A BA384G may also be remotely reset from the safe area. Any switch may be used but a Zener barrier is required to transfer the contact closure into the hazardous area which may be combined with the supply barrier so that only one package is required. A diode return barrier is not suitable for this application. Fig 2 illustrates how a BA384G may be reset from both the safe and the hazardous area.

Note: The BA384G may be configured to reset the total display to zero by operating the  and  push buttons simultaneously for more than two seconds in the totalising mode i.e. when the instrument is displaying flow. See 6.20

4.2 Use with Galvanic Isolators

Galvanic isolators are probably the simplest intrinsically safe interface to install as they provide isolation and do not require a high integrity earth connection.

Any galvanic isolator certified for the gas group in which the BA384G is installed, with output parameters less than the input parameters of the BA384G having the correct function may be used.

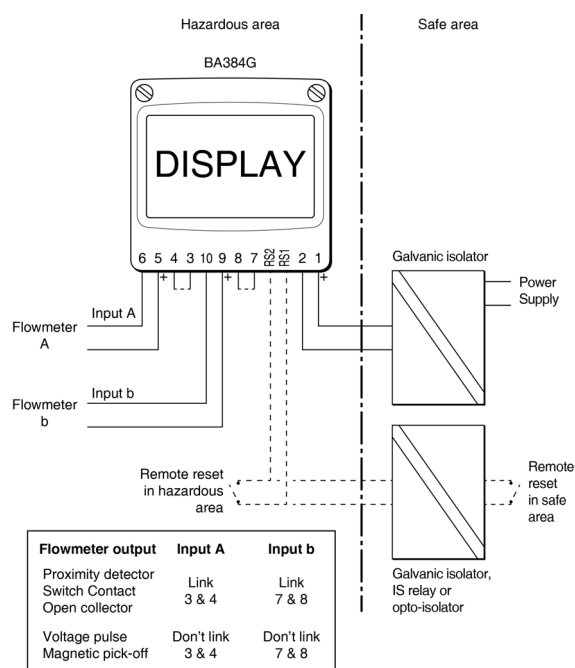

Fig 4 BA384G used with galvanic isolators

Fig 4 illustrates the basic circuit that is used for all BA384G installations protected by galvanic isolators. For simplicity, connections for the optional pulse output, 4/20mA output and alarms are shown in sections 8 and 11 of this manual.

Alternatively flowmeters may be located in the safe area. Fig 5 shows how additional galvanic isolators are used to transfer the pulse signal to the BA384G in the hazardous area, although it may be difficult to find isolators for some flowmeters. The two BA384G external input conditioning links should be positioned to match the output of the galvanic isolator not the flowmeter.

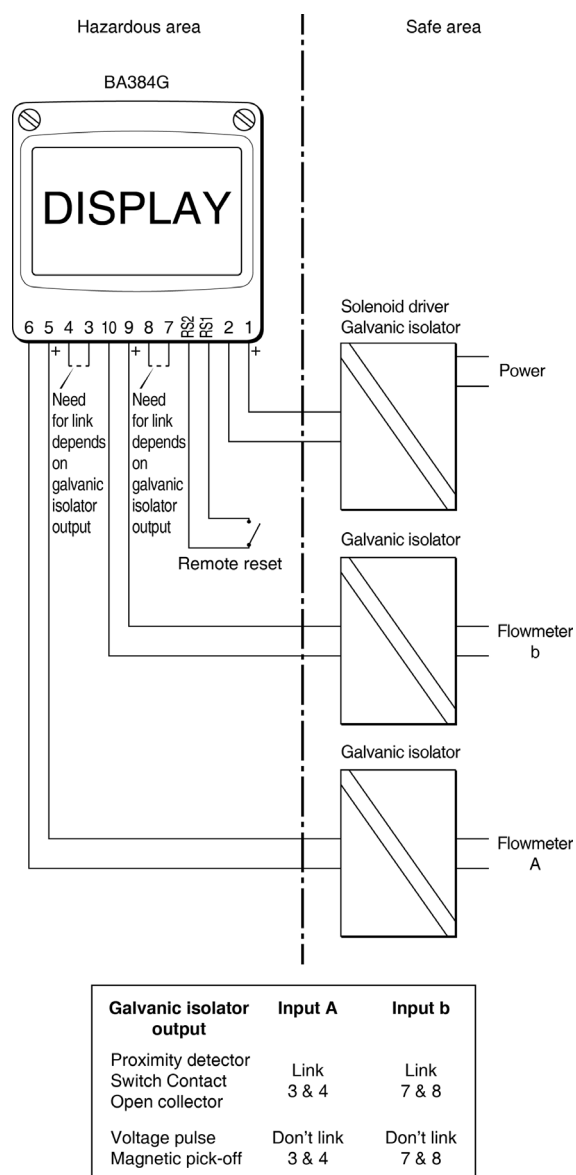

Fig 5 BA384G Rate Totaliser protected by galvanic isolators with sensors in safe area.

4.2.1 Power supply

The BA384G requires a minimum of 10V between terminal 1 & 2 and consumes:

	10mA	without optional backlight
plus	6mA	when terminals 3 & 4 are linked
plus	6mA	when terminals 7 & 8 are linked
plus	16mA	with optional backlight

Any galvanic isolator certified for the gas group in which the BA384G is installed may be used to power the instrument. The output safety parameters of the isolator must be equal to or less than the input safety parameters of terminals 1 & 2 and the voltage at terminals 1 & 2 must be greater than 10V. These requirements are not restrictive and allow a wide range of galvanic isolators, such as solenoid drivers, to be used.

4.2.2 Pulse inputs

As shown in Figs 4 and 5 both BA384G inputs can be directly connected to hazardous area flowmeters, or to safe area flowmeters via isolators. Galvanic isolators are not required in series with the input if an intrinsically safe flowmeter is located within the same hazardous area as the BA384G.

The BA384G Rate Totaliser may be used with flowmeters having a wide variety of pulse outputs. The following table shows the switching thresholds for each type. For reliable operation the Rate Totalisers input signal must fall below the lower threshold and rise above the upper threshold.

Sensor	Switching thresholds	
	Lower	Upper
Switch	100Ω	1000Ω
Proximity detector	1.2mA	2.1mA
Open collector	2kΩ	10kΩ
Magnetic pick-off	0mV	40mV peak
Voltage pulse low	1.0V	3.0V
Voltage pulse high	3.0V	10.0V

Switch contacts, proximity detectors and open collector sensors require energising which is achieved by linking two BA384G terminals together for each input as shown in Figs 4 and 5.

4.2.3 Switch contact input

Any flowmeter with a mechanically or magnetically activated switch contact output may be directly connected to input terminals 5 & 6 or 9 & 10. The flowmeter should be located in the same hazardous area as the BA384G, and the flowmeter and associated wiring should be able to withstand a 500V rms insulation test to earth. Most magnetically activated reed relays used in turbine flowmeters comply with these requirements. The BA384G contains a configurable debounce circuit to prevent contact bounce being counted. Three levels of de-bounce protection are independently available for each input. See section 6.7.

4.2.4 Open collector input

Certified intrinsically safe flowmeters with an open collector output may be directly connected to input terminals 5 & 6 or 9 & 10 providing the flowmeter is located in the same hazardous area as the BA384G, and the flowmeter and associated wiring can withstand a 500V rms insulation test to earth.

The BA384G contains a configurable debounce circuit to prevent false triggering. Three levels of de-bounce protection are independently available for each input. See section 6.7.

4.2.5 2-wire proximity detector input

Most certified intrinsically safe flowmeters incorporating a NAMUR 2-wire proximity detector may be directly connected to a BA384G input, providing the input safety parameters of the proximity detector are equal to or greater than the output safety parameters of a BA384G input. i.e.

U_i	\geq	10.5V dc
I_i	\geq	9.2mA dc
P_i	\geq	24mW

and the minimum operating voltage of the flowmeter (proximity detector) is less than 7.5V. The flowmeter must be located in the same hazardous area as the BA384G and with the associated wiring be able to withstand a 500V rms insulation test to earth.

The BA384G contains a configurable debounce circuit to prevent false triggering. Three levels of debounce protection are independently available for each input. See section 6.7.

4.2.6 Magnetic pick-off input

Flowmeters incorporating a magnetic pick-off to sense flow will have a low level voltage output unless the flowmeter incorporates an amplifier. $[0, L$ in the BA384G input configuration menu is a low level voltage pulse input intended for use with an intrinsically safe magnetic pick-off. When a BA384G input is configured for $[0, L$ it complies with the requirements for *simple apparatus* allowing connection to any certified intrinsically safe magnetic sensor having output parameters equal to or less than:

U_o	\leq	28V dc
I_o	\leq	200mA dc
P_o	\leq	0.84W

The maximum permitted cable parameters will be the flowmeter's C_o and L_o specified on its intrinsic safety certificate, less the BA384G input parameters C_i and L_i which are small and can often be ignored.

The flowmeter must be located within the same hazardous area as the BA384G and with the associated wiring be able to withstand a 500V rms insulation test to earth.

The BA384G contains a configurable debounce circuit to prevent false triggering of the instrument. See section 6.7.

4.2.7 Voltage pulse input

Two voltage pulse input ranges are independently selectable in the BA384G Rate Totaliser configuration menu, $U_{oL}L5 L$ and $U_{oL}L5 H$. When configured for either of the voltage pulse ranges, the input terminals 5 & 6 and 9 & 10 comply with the requirements for *simple apparatus*. This allows the inputs to be connected to any certified intrinsically safe voltage source within the same hazardous area as the BA384G having output parameters equal to or less than:

U_o	\leq	28V dc
I_o	\leq	200mA dc
P_o	\leq	0.84W

The BA384G Rate Totaliser may therefore be directly connected to most certified intrinsically safe flowmeters with a high level voltage signals.



The maximum permitted cable parameters will be defined by the intrinsic safety certification of the flowmeter less the BA384G input parameters which are small and can often be ignored.

The BA384G contains a configurable debounce circuit to prevent false triggering of the instrument. Three levels of de-bounce protection are independently available for each input, See section 6.7.

4.2.8 Remote reset

The BA384G total display may be remotely reset to zero by connecting terminals RS1 and RS2 together for more than one second. Permanent interconnection inhibits totalisation. Remote resetting may be accomplished by any mechanically operated switch located in the same hazardous area as the Rate Totaliser providing the switch and the associated wiring can withstand a 500V rms insulation test to earth. No galvanic isolator is required.

A BA384G may also be remotely reset from the safe area. Any switch may be used but a galvanic isolator is required to transfer the contact closure into the hazardous area. Fig 4 illustrates how a BA384G may be reset from both the safe and the hazardous area.

Note: The BA384G may be configured to reset the total display to zero by operating the  and  push buttons simultaneously for more than two seconds in the totalising mode i.e. when the instrument is displaying flow. See 6.20

5. INSTALLATION

5.1 Location

The BA384G Rate Totaliser is housed in robust IP66 glass reinforced polyester (GRP) enclosure incorporating an armoured glass window and stainless steel fittings making it suitable for exterior mounting in most industrial on-shore and off-shore installations. The Rate Totaliser should be positioned where the display is not in continuous direct sunlight. Special conditions apply for Zone 0 installations, see section 3.3.

Field wiring terminals are located on the rear of the Rate Totaliser assembly as shown in Fig 7.

To ensure electrical continuity between the two conduit or cable entries, the enclosure back-box is fitted with a bonding plate which includes an M4 earth stud. The bonding plate may be mounted on the inside or outside of the enclosure. If the carbon loaded GRP enclosure is not bolted to an earthed post or structure, this earth stud should be connected to a local earth or the plant potential equalising conductor.

An insulated M4 stud is provided in the bottom right hand corner of the back-box for interconnecting cable screens.

The BA384G Rate Totaliser may be pipe mounted using a BA393G pipe mounting kit, or panel mounted using a BA394G or BA395G panel mounting kit.

5.2 Installation Procedure

Fig 6 illustrates the instrument installation procedure.

- Remove the Rate Totaliser assembly by unscrewing the four captive 'A' screws.
- Mount the enclosure back-box on a flat surface and secure with screws or bolts through the four 'B' holes. Alternatively use one of the pipe or panel mounting kits which are available as accessories.
- Remove the temporary hole plug and install an appropriate IP and temperature rated M20 x 1.5mm cable gland or conduit fitting. If two entries are required, the supplied IP66 stopping plug should be replaced with an appropriate IP and temperature rated M20 x 1.5mm cable gland or conduit fitting.
- Connect the field wiring to the terminals as shown in Fig 7. Replace the instrument assembly on the back-box and evenly tighten the four 'A' screws.

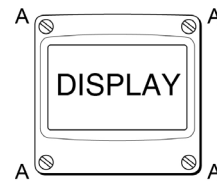

Step A

Unscrew the four captive 'A' screws and separate the indicator assembly and the back-box.

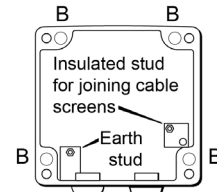

Step B

Secure the enclosure back-box to a flat surface with M6 screws through the four 'B' holes. Alternatively use a pipe mounting kit.

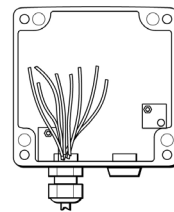

Step C

Remove the temporary hole plug and install an appropriate IP rated cable gland or conduit fitting. Feed the field wiring through the cable entry.

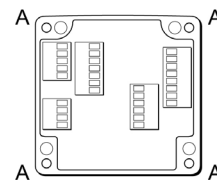

Step D

Terminate field wiring on the indicator assembly. Replace the indicator assembly on the enclosure back-box and tighten the four 'A' screws.

Fig 6 BA384G installation procedure

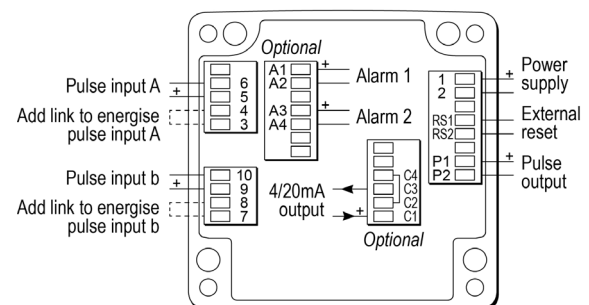
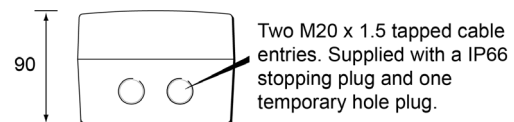
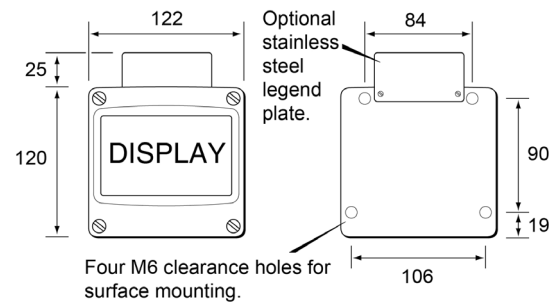

Fig 7 Dimensions and terminal connections

5.3 EMC

The BA384G complies with the requirements of the European EMC Directive 2014/30/EU. For specified immunity all wiring should be in screened twisted pairs, with the screens earthed at one point in the safe area.

5.4 Units of measurement and tag marking on scale card.

The Rate Totaliser's units of measurement and tag information are shown on a scale card which slides into the instrument.

New Rate Totalisers are supplied with a printed scale card showing the requested units of measurement and tag information. If this information is not supplied when the instrument is ordered, a blank scale card will be fitted which can easily be marked on-site with a dry transfer or a permanent marker. Custom printed scale cards are available from BEKA associates as an accessory.

To remove the scale card from a Rate Totaliser carefully pull the transparent tab at the rear of the instrument assembly away from the assembly as shown in Fig 8a.

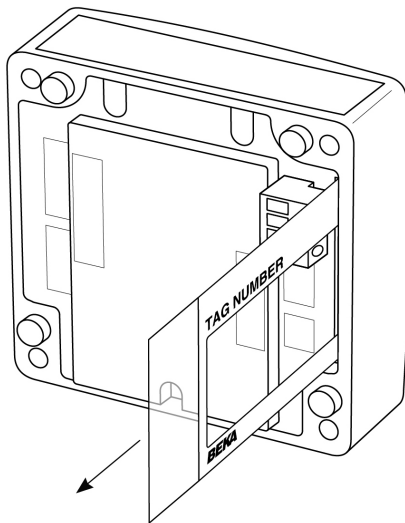

Fig 8a Removing scale card

To replace the scale card carefully insert it into the slot on the right hand side of the input terminals as shown in Fig 8b. Force should be applied evenly to both sides of the scale card to prevent it twisting. The card should be inserted until about 2mm of the transparent tab remains protruding.

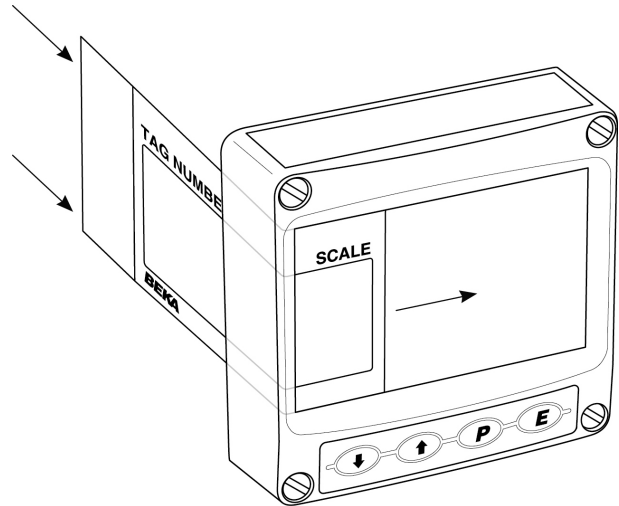

Fig 8b Inserting scale card into the instrument assembly.

6.0 CONFIGURATION AND CALIBRATION

The BA384G Rate Totaliser is configured and calibrated via four front panel push buttons. Figs 9 and 10 show the configuration structure and the menu.

Each menu function is summarised in section 6.3 of this manual and each summary includes a reference to more detailed information. The two sixteen segment linearisers and the pulse output are described separately in sections 7 and 8.

When factory fitted optional alarms and 4/20mA outputs are included, additional functions appear in the configuration menu which are described separately in section 11.

All new BA384G Rate Totalisers are supplied calibrated as requested at the time of ordering. If calibration is not requested, Rate Totalisers will have default configuration which is shown in the following table, but can easily be re-configured on-site.

Function	Display	Default
Access code	Code	0000
Function	Function	Std
A Input*	INPUT-A	0P0L
Debounce	debounce	defrult
Update	update	0.5
Count	Count	A:b
Upper display	di SP-1	total
Lower display	di SP-2	Std
Decimal point	dP	total00000000 rate 00000
Factor input A*	FRCtar-R	00 1.00
Total scale factor input A*	SCALE-t-R	00 1.00
Rate scale factor input A*	SCALE.r-R	00 1.00
Timebase	t-base	t-b-0 (secs)
Filter for input A*	Filter-R	24
Clip-off for input A*	CLP.off-R	00000
Local total reset	Clr tot	off
Local grand total reset	Clr Gtot	off
Pulse source	Source di, di, dE duration	SCALEd 1 0.1
External reset	ELR	ELR Rnb
Access code	Code	0000

Notes:

1. Defaults for input A are shown. Functions which are duplicated for input b are identified with an *. The input b function has the same default as the input A function.
2. While the instrument is being configured totalisation continues so that any flow occurring during this time is recorded.

6.1 Calibration structure



Fig 9 shows the BA384G calibration structure. Two identical channels enable the rate and total displays for input A and input b to be independently configured.

Configuration functions which only apply to one Rate Totaliser channel are identified with a suffix, i.e. the rate scale factor $SCALE.r-R$ applies to channel A and $SCALE.r-b$ applies to channel b. Configuration functions that do not have a channel suffix, such as the timebase $t-base$, apply to both channels.

The frequency of pulses received at each input is divided by $FRCtar-R$ or $FRCtar-b$, which is usually set to the K-factor of the flowmeter, thus converting the flowmeter output into engineering units. When linearisation Lin is selected in the Function sub-menu, up to 16 values for $FRCtar-R$ and $FRCtar-b$ may be entered, each starting at a specified input pulse frequency. Linearisation compensates for flowmeter nonlinearity and increases totalisation accuracy. See section 7.

$SCALE-r$ is a dividing factor that converts the output from $FRCtar$ into the required engineering units for the rate display. e.g. if the output from $FRCtar$ is one pulse per litre and the rate display is required in gallons, $SCALE-r$ should be set to 4.5461 which is the number of litres in an imperial gallon.

The total flow display is independent of the rate display. $SCALE-t$ is a dividing factor that converts the output from $FRCtar$ into the required engineering units for the total display. e.g. if the output from $FRCtar$ is one pulse per litre and the total display is required in thousands of gallons, $SCALE-t$ should be set to 4,546.1 which is the number of litres in 1,000 imperial gallons.

The $Count$ function allows the sum or difference of the two input flow rates and the two flow totals to be displayed, but is only meaningful if they are calibrated to display the same engineering units. When the BA384G Rate Totaliser is in the totalising mode the following displays can be selected using the  or  push buttons:

Select	Totaliser displays
input R	Input A rate and total flow
input b	Input b rate and total flow
R:b or R:-b	Composite rate and total flow depends upon how the $Count$ function has been configured See 6.9

The timebase $t-base$ is a multiplying factor that determines if the instrument displays flow rate per second, per minute or per hour.

The BA384G uses 'real' decimal points, moving the position of a decimal point in a scale factor will therefore affect the instrument calibration.

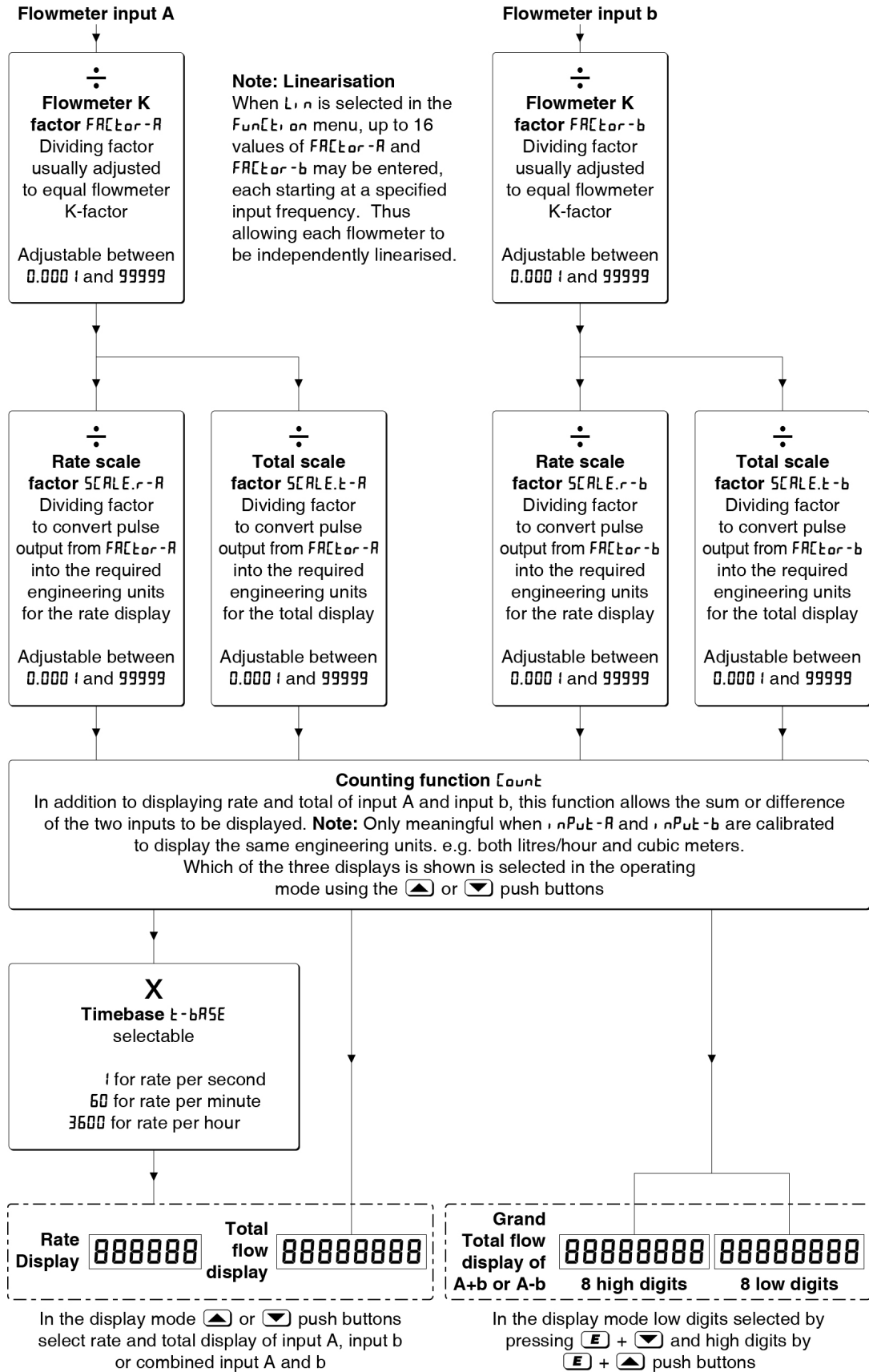

Fig 9 Calibration structure

Unless otherwise specified menu functions are shown on the upper display

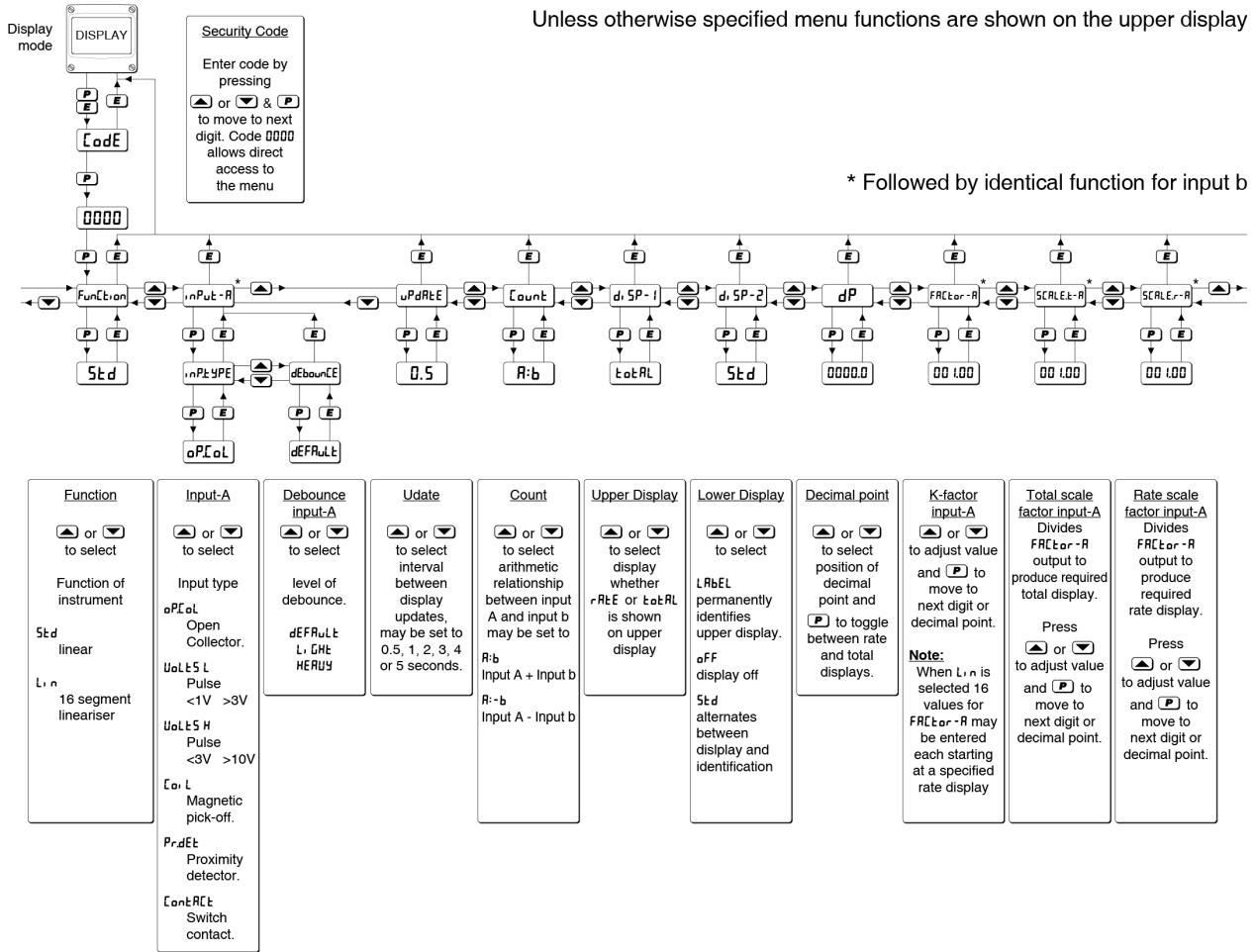
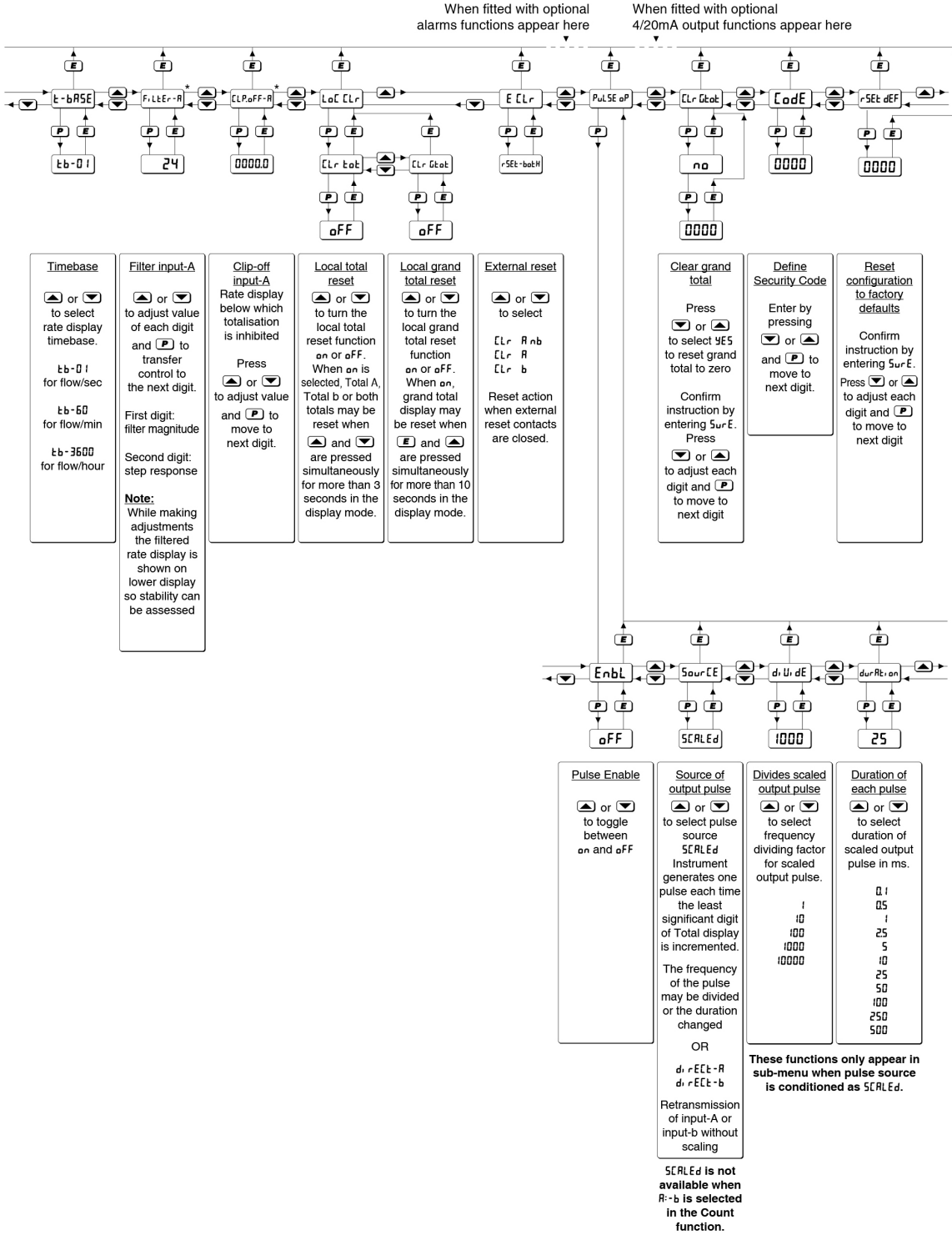













Fig 10 Rate Totaliser Configuration menu





6.2 Accessing configuration functions

Throughout this manual push buttons are shown as    and  and legends displayed by the instrument are shown in a seven segment font exactly as they appear on the instrument display e.g. $\text{Rate} - R$ and $\text{Filter} - R$.

Access to the configuration menu is obtained by operating the  and  push buttons simultaneously. If the instrument is not protected by an access security code the first parameter Function will be displayed. If a security code other than the default code 0000 has already been entered, the instrument will display Code . Press  to clear this prompt and enter the security code for the instrument using the  or  push button to adjust the flashing digit, and the  push button to transfer control to the next digit. If the correct code has been entered pressing  will cause the first parameter Function to be displayed. If an incorrect code is entered, or a push button is not operated within ten seconds, the instrument will automatically return to the totalising mode.

All configuration functions and prompts are shown on the upper eight digit display except the filter which uses both the upper and lower displays.

Once within the main configuration menu the required parameter can be selected by scrolling through the menu using the  or  push buttons. The configuration menu is shown diagrammatically in Fig 10.

When returning to the totalising mode following reconfiguration, the Rate Totaliser will display Rate followed by Rate while the new information is stored in permanent memory.

If during configuration a button is not operated within 60 seconds, the instrument will automatically return to the totalising mode and any configuration changes will not be stored. When configuring a BA384G Rate Totaliser it is therefore advisable to occasionally return to the totalising mode to ensure that recent configuration changes are stored in permanent memory.

6.3 Summary of configuration functions

This section summarises all the configuration functions. When read in conjunction with Fig 10 it provides a quick aid for configuring the Rate Totaliser. If more detail is required, each section of this summary contains a reference to a full description of the function.

For simplicity this summary and Fig 10 only show functions that configure both inputs and those which configure input A. Immediately following each function with an R suffix in the configuration menu is an identical function with a b suffix that configures the 'b' input. In this instruction manual descriptions of 'A' input functions which are followed by an identical function for the 'b' input are identified with an *.

Display	Summary of function
Function	<p>Rate totaliser function Defines the relationship of both pulse input channels and the Rate Totaliser display. May be set to:</p> <p>Std Standard linear relationship</p> <p>Lin Separate 16 segment fully adjustable lineariser in each input channel which are described in section 7. See section 6.4</p>
$\text{Rate} - R$	<p>Input* Contains two sub-functions: See section 6.5</p> <p>INPUT TYPE Configures the Rate Totaliser input to accept one of six types of input:</p> <ul style="list-style-type: none"> Open Open collector ● $\text{Vp} < 1 > 3V$ Voltage pulse <1 >3V $\text{Vp} < 3 > 10V$ Voltage pulse <3 >10V Mag Magnetic pick-off Prox Proximity detector ● Switch Switch contact ● <p>● Requires input to be energised by linking terminals 3 & 4 for input A, and terminals 7 & 8 for input b. See section 6.6</p>

Display	Summary of function	Display	Summary of function
	<p>dEbounCE Defines level of input de-bounce applied to the pulse input to prevent false counting: dEFRAULt HERUS L:GHt See section 6.7</p>		
uPdRtE	<p>Display update interval Rate totaliser display update interval adjustable between 0.5 and 5 seconds. See section 6.8</p>		
Count	<p>Composite display Defines relationship between input A and Input b for composite display. Select: R: b for Input A + Input b R: -b for Input A – Input b See section 6.9</p>		
d, 5P-1	<p>Upper display Defines whether tAtRL or rRtE is shown on the upper display. The other variable may be shown on the lower display, providing the lower display is on in function d, 5P-2. See section 6.10</p>		
d, 5P-2	<p>Lower display Defines the function of the lower display. It can show the selected flow variable briefly alternating with the display identification, permanently display the identification of the upper display or it may be disabled. Select: 5td Displays selected flow variable briefly alternating with the display identification, except for composite display. LRbEL Permanently displays identification of upper display. oFF Lower display disabled. See section 6.11</p>		
		dP	<p>Decimal points Defines the position of the decimal point in both the rate and total displays. See section 6.12</p>
		FRCtOr-R	<p>Input A flowmeter K-factor * Each input of the rate totaliser is divided by FRCtOr-R or FRCtOr-b, which are usually set to the K-factor of the flowmeter, thus converting the flowmeter output into engineering units. FRCtOr may be adjusted between 0.0001 and 99999. When the 16 segment lineariser 'Lin' is selected in the FunCEtion sub-menu, up to 16 values for FRCtOr-R may be entered, each starting at a specified input pulse frequency to compensate for errors resulting from flowmeter nonlinearity.. See section 6.13 & Fig 9</p>
		5CRLE-t-R	<p>Total Scale Factor * 5CRLE-t is a dividing factor that converts the pulse output from FRCtOr into a total with the required engineering units. e.g. if the output from FRCtOr is one pulse per litre and the total display is required in thousands of gallons, 5CRLE-t should be set to 4546.1 which is the number of litres in 1,000 imperial gallons. 5CRLE-t may be adjusted between 0.0001 and 99999. The total flow display is independent of the rate display. See section 6.14 & Fig 9</p>
		5CRLE-r-R	<p>Rate Scale Factor * 5CRLE-r is a dividing factor that converts the pulse output from FRCtOr into a rate with the required engineering units. e.g. if the output from FRCtOr is one pulse per litre and the rate display is required in gallons, 5CRLE-r should be set to 4.5461 which is the number of litres in an imperial gallons. 5CRLE-r may be adjusted between 0.0001 and 99999. The flow rate display is independent of the total flow display. See section 6.15 & Fig 9</p>

Display	Summary of function	Display	Summary of function
±-bRSE	<p>Timebase Selectable multiplier allowing flow rate to be displayed in units per second, per minute or per hour.</p> <p>Select:</p> <ul style="list-style-type: none"> ±b-01 for flow / second ±b-60 for flow / minute ±b-3600 for flow / hour <p>See section 6.16</p>	E CLR	<p>External reset This function defines which totals are reset to zero when terminals RS1 and RS2 are connect together for more than 1 second.</p> <p>Select:</p> <ul style="list-style-type: none"> CLR Rnb to reset totals A and b CLR R to reset total A CLR b to reset total b <p>See section 6.22</p>
F, LLEr-A	<p>Display filter * An adjustable digital filter to reduce noise on the rate display. Two parameters each adjustable between 0 and 9. The first digit defines the amount of filtering applied to the display, the second deviation from the displayed rate at which the filter will be overridden and the rate display will move rapidly to the new value.</p> <p>See section 6.17</p>	CLR-Gtot	<p>Resets grand total to zero This function resets the grand total to zero from within the configuration menu when CLR.YE5 is selected.</p> <p>Note: Once reset, the grand total can not be recovered.</p> <p>See section 6.23</p>
CLP.oFF-A	<p>Clip-off * To prevent totalisation of very low flow rates, clip-off enables the user to select a flow rate for each input below which totalisation is inhibited.</p> <p>See section 6.18</p>	Code	<p>Security code Defines a four digit alphanumeric code that must be entered to gain access to the configuration menu. Default code 0000 disables the security function and allows unrestricted access to all configuration functions when the P and E buttons are operated simultaneously in the totalising mode.</p> <p>See section 6.24</p>
Lo CLR	<p>Local reset Contains sub-menu with two functions which when enabled allow the two totals and the grand total to be reset to zero via the front panel push buttons when the Rate Totaliser is in the totalising mode.</p> <p>See section 6.19</p> <p>Local total reset CLR tot When on is selected, total A, total b or both totals are reset to zero when the ▼ and ▲ buttons are operated simultaneously for more than 3 seconds in the totalising mode.</p> <p>See section 6.20</p> <p>Local grand total reset CLR Gtot When on is selected, grand total may be reset to zero when E and ▲ buttons are operated simultaneously for more than 10 seconds in the totalising mode. Note: Once reset, the grand total can not be recovered.</p> <p>See section 6.21</p>	rSEt dEF	<p>Reset to factory defaults Resets the instrument to the factory defaults shown in section 6 when the instruction is confirmed by entering SurE.</p> <p>See section 6.25</p>

6.4 Rate Totaliser function: $F_{un}L_{t, on}$

This function determines whether the BA384G Rate Totaliser has a standard linear function, or if the two separate adjustable sixteen segment linearisers, one for each of the two flowmeter input, are activated. To reveal the existing setting select $F_{un}L_{t, on}$ from the configuration menu and press P .

S_{td} Linearisers are not activated
 L_{in} Linearisers are activated

If the function is set as required, press E to return to the configuration menu, or press the \blacktriangledown or \blacktriangle button to change the setting, followed by the E button to return to the $F_{un}L_{t, on}$ prompt in the configuration menu.

S_{td} Linear

Provides a linear relationship between the pulse input and the Rate Totaliser displays for input A and input b.

L_{in} 16 segment adjustable lineariser

Activates an independent sixteen segment adjustable lineariser for each input. When L_{in} is selected functions $FR_{t, or-A}$ and $FR_{t, or-b}$ are expanded to allow up to 16 values to be entered each starting at a specified input pulse frequency. This allows $FR_{t, or-A}$ and $FR_{t, or-b}$ to be set to the K-factor of each flowmeter at multiple flow rates thus minimising errors caused by the nonlinearity of the flowmeter's K-factor.

Detailed information about the lineariser, including configuration information is contained in section 7 of this instruction manual.

6.5 Input*: $i_{n}P_{ut-A}$

The Input function contains two sub-functions $i_{n}P_{ut-YPE}$ and $dEb_{oun}CE$ described in the following sections which configure the Rate Totaliser input and define the amount of input noise rejection.

6.6 Input type: $i_{n}P_{ut-YPE}$

$i_{n}P_{ut-YPE}$ is a sub-menu which appears in both the $i_{n}P_{ut-A}$ and $i_{n}P_{ut-b}$ functions. It defines the type of flowmeter sensor or pulse that may be connected to the input. To check or change the type of input, select $i_{n}P_{ut-A}$ or $i_{n}P_{ut-b}$ in the configuration menu and press P which will reveal the $i_{n}P_{ut-YPE}$ prompt, pressing P again will reveal the existing input. If set as required press E twice to return to the configuration menu, or repeatedly press the \blacktriangledown or \blacktriangle button until the required type of input is displayed and then press E twice to return to the configuration menu.

One of following six types may be selected for each input:

		Switching thresholds	
		Low	High
$U_{dL}L_{5L}$	Voltage pulse low ¹	1	3V
$U_{dL}L_{5H}$	Voltage pulse high ¹	3	10V
L_{oL}	Magnetic pick-off	0	40mV
$P_{r.dEt}$	Proximity detector ²	1.2	2.1mA
$L_{on}tR_{Et}$	Switch contact ²	100	1000 Ω
$oP_{L}oL$	Open collector ²	2	10k Ω

Notes:

1. Maximum voltage input +28V.
2. For flowmeter sensors connected to input A that require energising i.e. proximity detector, switch contact and open collector, terminals 3 & 4 of the Rate Totaliser should be linked together. Similarly for flowmeter sensors connected to input b that require energising, terminals 7 & 8 should be linked together.
3. To count correctly, the input pulse must fall below the lower switching threshold and rise above the higher switching threshold.
4. See section 6.7 for typical maximum counting frequency.

6.7 Debounce*: $dEb_{oun}CE$

$dEb_{oun}CE$ is an adjustable sub-menu which appears in both the $i_{n}P_{ut-A}$ and $i_{n}P_{ut-b}$ functions. De-bounce prevents the Rate Totaliser miscounting when the input pulse has noisy edges, such as those resulting from a mechanical contact closing and bouncing. Three levels of protection may be selected and the amount of de-bounce applied depends upon the type of Rate Totaliser input that has been selected in the $i_{n}P_{ut-YPE}$ function.

The following table shows the minimum time that the input pulse must be continuously above the upper input switching threshold and continuously below the lower switching threshold to ensure that the Rate Totaliser processes the input pulse. Input switching thresholds are shown in section 6.6.

De-bounce level	Minimum input pulse width	
	Type of input	
	Contact	All others
Default	1,600 μ s	40 μ s
Heavy	3,200 μ s	350 μ s
Light	400 μ s	5 μ s

The Rate Totaliser's maximum counting frequency depends upon the debounce level selected, the shape of the input pulse and its amplitude. The following table assumes a square wave input and is only included for guidance. The maximum reliable counting frequency will be lower if the input pulses have sloping edges and the pulse amplitude only slightly exceeds the input switching thresholds.

ONLY FOR GUIDANCE		
De-bounce level	Maximum operating frequency	
	Type of input	
	Contact	All others
Default	250Hz	12kHz
Heavy	120Hz	2kHz
Light	1,000Hz	100kHz

The minimum counting frequency is 0.01Hz. Below this frequency the rate display will be forced to zero.

The *dEbounCE* sub-function is located in the *i nPult-R* and *i nPult-b* functions. Select *i nPult-R* or *i nPult-b* in the configuration menu and press **P** which will reveal the *i nP.tYPE* prompt, press the **▼** or **▲** button to select *dEbounCE* followed by **P** to reveal the existing setting. Pressing the **▼** or **▲** button will scroll through the three levels. When the required level has been selected, pressing **E** twice will enter the selection and return the display to the *i nPult-R* or *i nPult-b* prompt in the configuration menu.

6.8 Display update interval: *uPdRtE*

If either the rate or the total display is likely to change rapidly, a longer interval between display updates may simplify reading the Rate Totaliser displays. This function allows one of six different display intervals between 0.5 and 5 seconds to be selected. The selected display update interval does not affect the update time of any other instrument function. i.e. instrument accuracy is not affected.

To adjust the update interval select *uPdRtE* from the configuration menu and press **P** to reveal the existing setting. Pressing the **▼** or **▲** button will scroll through the six times. When the required interval has been selected, press **E** to enter the selection and return to the configuration menu.

6.9 Composite display: *Count*

The BA384G can produce a composite rate and total display from the sum or difference of Input-A and Input-b. This composite display is only meaningful if Input-A and Input-b are calibrated to have the same engineering units of display. This function defines the composite display.

To check or change the composite display function select *Count* in the configuration menu and press **P** which will reveal the current setting which may be changed by pressing the **▼** or **▲** button.

Select:

R:b to display Input A + Input b

R:-b to display Input A – Input b

When set as required press **E** to return to the configuration menu.

6.10 Upper display: *d, 5P-1*

Usually total flow is shown on the larger upper eight digit display, but this function allows rate to be shown on the upper display and total flow on the smaller lower display which has six positive digits or five digits with a negative sign.



To check the status of the upper display, select *d, 5P-1* from the configuration menu and press **P** which will reveal if the display is showing *rRtE* or *totRL*. The setting can be changed by pressing the **▼** or **▲** button followed by the **E** button to enter the selection and return to the configuration menu.

6.11 Lower display: *d, 5P-2*

The lower display is normally used for displaying the rate of flow, but this function also allows it to intermittently or continuously identify which of the two inputs is being displayed, or the lower display may be disabled.



To check the status of the lower display, select *d, 5P-2* from the configuration menu and press **P** which will reveal the existing setting which can be changed by pressing the **▼** or **▲** button followed by the **E** button to enter the selection and return to the configuration menu.





The following table shows the effect of the three *d, 5P-2* options when input A, input b or the composite display are selected in the totalising mode.

Display selected using the  or  buttons in the tota-lising mode.	Lower display d, 5P-2 setting in configuration menu.		
	Std	LRbEL	oFF
Composite	Composite rate and total shown permanently	Composite rate and total shown permanently	R:b or R:-b shown briefly. No numerical value
, nPul-t-R	Numerical value alternating with , n-R shown briefly every few seconds	, n-R shown continuously. No numerical value	, n-R shown briefly. No numerical value
, nPul-t-b	Numerical value alternating with , n-b shown briefly every few seconds	, n-b shown continuously. No numerical value	, n-b shown briefly. No numerical value

6.12 Position of the decimal points: dP

The upper and lower displays have eight and six digits respectively. This function enables the position of the decimal point on both displays to be independently positioned.

To adjust the position of the decimal points select dP from the configuration menu and press . The upper display defined as the rate or total display by function d, 5P-1 (section 6.10) will be activated and identified by the display annunciator as Rate or Total. The decimal point, which may be positioned between any of the digits or may be absent is positioned by operating the  or  push button.





When the decimal point in the upper display has been positioned pressing the  button will transfer control to the lower display variable, but it will be shown and annunciated on the larger upper display. The decimal point may be positioned in the same way by operating the  or  push buttons. When set as required enter the settings and return to the configuration menu by operating the  button.

6.13 Flowmeter K-factor: FRCtor-R *

The rate totaliser pulse input A is divided by FRCtor-R, which is adjustable between 0.0001 and 99999. For flow applications FRCtor-R should be set to the K-factor of the flowmeter connected to input A. K-factor is the number of pulses that the flowmeter produces per unit volume of flow e.g. 20 pulses per litre. FRCtor-R therefore converts the flowmeter output into engineering units ready for further scaling to produce the required rate and total flow displays. See Fig 9.







When the 16 segment lineariser L, n is selected in Funct, on up to 16 values of FRCtor-R may be entered, each starting at a specified input pulse frequency, which may be adjusted to compensate for flowmeter non-linearity. See section 7 of this manual.

To check or change the value, select FRCtor-R from the configuration menu and press  which will reveal the existing value with one digit flashing.

The flashing digit may be adjusted by pressing the  or  button. When this digit has been adjusted, pressing  will transfer control to the next digit. When all the digits have been adjusted pressing  again will transfer control to the decimal point that may be positioned between any of the digits, or may be omitted by moving it to the right of the least significant digit. Finally press  to return to the FRCtor-R prompt in the configuration menu.

6.14 Total scale factor*: SCALE.t-R

SCALE.t-R is a dividing factor adjustable between 0.0001 and 99999 that enables total flow to be displayed in the required engineering units. e.g. if the output from FRCtor-R is one pulse per litre and the total display is required in thousands of gallons, SCALE.t-R should be set to 4546.1 which is the number of litres in 1,000 imperial gallons. The total flow display is independent of the rate display.

To check or change the total scale factor select SCALE.t-R from the configuration menu and press  which will reveal the existing value with one digit flashing. The value of the flashing digit may be changed by pressing the  or  button. When this digit has been adjusted as required, pressing  will transfer control to the next digit. When all the digits have been adjusted pressing again  will transfer control to the decimal point that may be positioned between any of the digits, or may be omitted by moving it to the right of the least significant digit. When the required total scale factor has been entered, press  to return to the SCALE.t-R prompt in the configuration menu.

6.15 Rate scale factor*: $SCALE.R-R$

$SCALE.R-R$ is a dividing factor adjustable between 0.0001 and 99999 that enables the flow rate to be displayed in the required engineering units. e.g. if the output from $FRCLE.R-R$ is one pulse per litre and the rate display is required in gallons, $SCALE.R-R$ should be set to 4.5461 which is the number of litres in an imperial gallons.

The units of the rate display are volume per unit of time. The unit of time is the timebase of the instrument which is determined by $TBASE$ described in section 6.16.

To check or change the rate scale factor select $SCALE.R-R$ from the configuration menu and press P which will reveal the existing value with one digit flashing. The value of the flashing digit may be changed by pressing the \blacktriangledown or \blacktriangle button. When this digit has been adjusted as required, pressing P will transfer control to the next digit. When all the digits have been adjusted pressing P again will transfer control to the decimal point which may be positioned between any of the digits, or may be omitted by moving it to the right of the least significant digit. When the rate scale factor has been entered, press E to return to the $SCALE.R-R$ prompt in the configuration menu.

6.16 Timebase: $TBASE$

The timebase multiplies the rate display by 1, 60 or 3,600 depending upon whether the Rate Totaliser is required to display flow rate per second, per minute or per hour. See Fig 9.

To check or change the timebase, select $TBASE$ from the configuration menu and press P which will reveal the existing setting. Pressing the \blacktriangledown or \blacktriangle button will scroll through the following three options to display:

$TB-1$	for flow / second
$TB-60$	for flow / minute
$TB-3600$	for flow / hour

When the required multiplier is displayed press E to return to the $TBASE$ prompt in the configuration menu.

6.17 Display filter*: $FLTER-R$

The digital display filter associated with each input has two independent adjustable parameters enabling the rate display response to be tailored for optimum performance. The filter parameters are controlled by a two digit number. The first digit defines the amount of filtering applied to the display as shown below.

First digit	Filter time constant seconds
0X	0
1X	1.3
2X	4.3
3X	6.5
4X	8.7
5X	11.3
6X	15.7
7X	20.9
8X	25.2
9X	31.5

The second digit defines the deviation from the displayed rate at which the filter will be overridden and the rate display will move rapidly to the new value.

Second digit	Magnitude of step change which will produce a rapid response
X0	off
X1	1%
X2	2%
X3	4%
X4	8%
X5	12%
X6	16%
X7	24%
X8	32%
X9	64%

By careful adjustment of the two parameters a stable display with an acceptable input step response can be obtained for most applications.

During commissioning it is recommended that initially the second digit is set to 0 (off) and the first digit is adjusted to provide acceptable rate display stability. The second digit should then be increased until the selected step size is greater than the noise on the display signal, at which setting the rate display will become stable. These will be the optimum filter parameters for acceptable rate display stability and a fast response to a large rapid flow rate change.

To check or change the filter select `F, LTER-R` in the configuration menu and press `[P]` which will reveal the current settings with the first digit flashing. Pressing the `[▼]` or `[▲]` button will change the flashing digit and `[P]` will transfer control to the second digit. While making adjustments the filtered rate display is shown on the lower display so that stability can be assessed while adjustments are being made. When set as required, press the `[E]` button to enter the revised parameters and return to the `F, LTER-R` prompt in the configuration menu.

6.18 Clip-off*: `[LP.off-R]`

To prevent totalisation of very low flow rates that over long periods may result in significant totalisation errors, the BA384G may be configured to stop totalising when the flow rate falls below an adjustable threshold.

To check or change the clip-off threshold select `[LP.off-R]` from the configuration menu and press `[P]` which will reveal the existing setting. The threshold is shown in the units already selected for the flow rate display. One digit will be flashing. The value of the flashing digit may be changed by pressing the `[▼]` or `[▲]` button. When this digit is correct, pressing `[P]` will transfer control to the next digit. When clip-off is set as required, press the `[E]` button to enter the revised figure and return to the `[LP.off-R]` prompt in the configuration menu.

When the Input-A flow rate falls below the clip-off threshold, the rate display will show zero flow, totalisation will stop and the `HOLD` annunciator will be activated. The flow indicator will continue to rotate for 2 seconds each time an input pulse is received i.e. at input pulse frequencies above 0.5Hz it will appear to rotate continuously.

Note: To avoid confusion, when `FR[tor-R]`, `SRLE.r-R`, `t-bR5E`, or the position of the rate display decimal point are changed, clip-off will automatically be reset to zero. A new clip-off threshold must be entered after changes to any of these functions have been made.

6.19 Local reset: `L[LR]`

The Local reset function contains two sub-functions `[LR tot]` and `[LR gtot]` which when enabled allow each input total and the grand total to be reset to zero via the instrument push buttons while the Rate Totaliser is in the totalising mode.

6.20 Local total reset: `[LR tot]`

`[LR tot]` is a sub-menu in the `L[LR]` function which when activated allows an operator to reset total A, total b or both totals and any stored pulses in the pulse output by operating the `[▼]` or `[▲]` push buttons simultaneously for more than three seconds while the BA384G is in the totalising mode.

To check or change the function select `L[LR]` in the configuration menu and press `[P]` which will reveal the `[LR tot]` prompt, operate `[P]` again to show if the local total reset is `on` or `off`. If set as required operate the `[E]` button twice to return to the configuration menu, or the `[▼]` or `[▲]` button to change the setting followed by the `[E]` button twice to enter the change and return to the `L[LR]` prompt in the configuration menu.

Note: The total display may also be reset to zero remotely by connecting terminals RS1 and RS2 together for more than one second. See sections 3.6; 4.1.8 and 4.2.8 of this manual.

6.21 Local grand total reset: `[LR gtot]`

The grand total is a separate sixteen digit counter which is incremented in parallel with the composite total input A+b or input A-b, but is not zeroed when any of the displayed totals are reset to zero. The grand total may be viewed in the totalising mode in two eight digit sections as described in section 2.2 of this manual.

`[LR gtot]` is a sub-menu in the `L[LR]` function which when activated allows the operator to reset the grand total display to zero with the BA384G in the totalising mode by operating the `[E]` and `[▲]` push buttons simultaneously for more than ten seconds.

To check or change the local grand total reset select `L[LR]` in the configuration menu and press `[P]` which will reveal `[LR tot]`. Using the `[▼]` or `[▲]` button select `[LR gtot]` and press `[P]` which will show if the local grand total reset function is `on` or `off`. If set as required operate the `[E]` button twice to return to the configuration menu, or the `[▼]` or `[▲]` button to change the setting followed by the `[E]` button twice to enter the change and return to the `L[LR]` prompt in the configuration menu.

6.22 External reset: E [Lr

The BA384G total displays can be remotely reset to zero when terminals RS1 and RS2 are connected together for more than one second. This function defines which totals are reset.

To check or change which totals are reset, select E [Lr from the configuration menu and press **P** which will reveal the existing setting. Using the **▼** or **▲** button select the required option:

[Lr Rnb	to reset total A and total b
[Lr R	to reset total A
[Lr b	to reset total b

When the required option is displayed press **E** to save the selection and return to the E.[Lr prompt in the configuration menu.

6.23 Grand total reset from configuration menu: [Lr Gt0t

The grand total is a separate sixteen digit counter which is incremented in parallel with the composite total input A+b or input A-b, but is not zeroed when the two individual totals input A and input b are reset to zero. The grand total may be viewed with the instrument in the totalising mode as two eight digit sections as described in section 2.2 of this manual.

The grand total can be reset to zero from within the configuration menu using this [Lr Gt0t function, or from the totalising mode if sub-function [Lr Gt0t is activated in the L0[[Lr function – see 6.21.

To zero the grand total from within the configuration menu select [Lr Gt0t and press **P** which will cause the instrument to display [Lr.n0 with n0 flashing. Press the **▼** or **▲** push button until [Lr.5E5 is displayed and then press **P** which will result in a 0000 prompt being displayed with the first digit flashing. This is a request for the instruction to be confirmed by entering 5urE using the **▼** or **▲** button to adjust the flashing digit and the **P** button to move control to the next digit. When entered pressing **E** will reset the grand total to zero and return the Rate Totaliser to the configuration menu.

Note: Once reset, the grand total can not be recovered.

6.24 Security code: [0dE

Access to the instrument configuration menu may be protected by a four digit alphanumeric security code which must be entered to gain access. Unless otherwise requested, new instruments are configured with the default security code 0000 which allows unrestricted access to all configuration functions.

To enter a new security code select [0dE from the configuration menu and press **P** which will cause the Rate Totaliser to display 0000 with one digit flashing. The flashing digit may be adjusted using the **▼** or **▲** push button, when set as required operating the **P** button will transfer control to the next digit. When all the digits have been adjusted press **E** to save the new code and return to the [0dE prompt in the configuration menu. The revised security code will be activated when the Rate Totaliser is returned to the totalising mode.

Please contact BEKA associates sales department if the security code is lost.

6.25 Reset to factory defaults: r5Et dEF

This function resets the BA384G Rate Totaliser including the two linearisers, to the factory default configurations which are shown in section 6.0

To reset the Rate Totaliser to the factory default configurations select r5Et dEF from the configuration menu and press **P** which will result in a 0000 display with the first digit flashing. This is a request to confirm the reset to factory default instruction by entering 5urE. Using the **▼** or **▲** button set the flashing digit to 5 and press **P** to transfer control to the second digit which should be set to u. When 5urE has been entered, pressing the **E** button will reset the BA384G to the factory defaults and return the instrument to the totalising mode.

Note: Once reset, the grand total can not be recovered.

7. LINEARISERS

The BA384G Rate Totaliser can produce accurate results when used with flowmeters having K-factors that vary with the flow rate, such as a turbine meter used over a wide range of flows. Each channel of the Rate Totaliser has an independent sixteen segment straight-line lineariser that may be adjusted to compensate for the nonlinearity of the flowmeter connected to the input as shown in Fig 11.

The two linearisers are enabled by selecting *L*₁ in *F*_{UN}*L*_{ION} – see section 6.4. The configuration menu shown in Fig 10 remains basically unchanged, except that up to 16 values of the flowmeter K-factor, can be entered as *L*-*F**R**E**T**O**R*, together with *P*_{ULSE} *F**R* the corresponding input frequency at which each starts in the *F**R**E**T**O**R* *A* and *F**R**E**T**O**R* *B* functions. Fig 12 shows how the *F**R**E**T**O**R* *A* is extended.

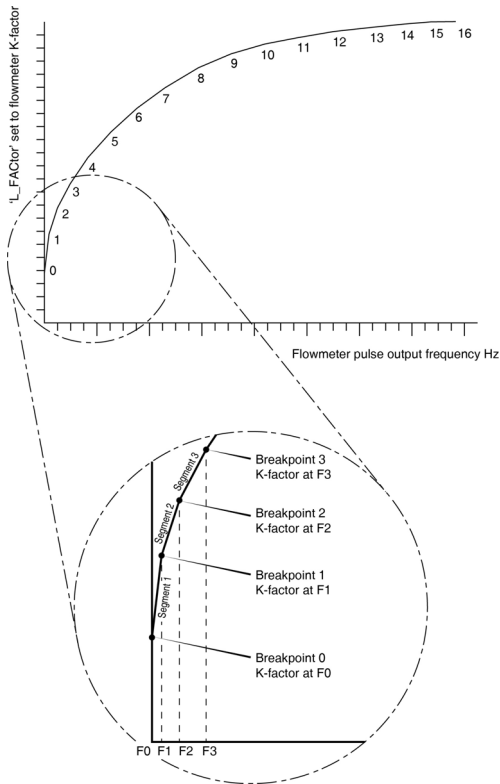

Fig 11 shows a typical linearising characteristic

The lineariser configuration is retained irrespective of how *F*_{UN}*L*_{ION} in the Rate Totaliser configuration menu is subsequently changed. It is therefore possible to select and deselect the linearisers without having to reconfigure them.

7.1 Flowmeter specification

Flowmeters are usually supplied with a calibration certificate specifying the average K-factor and the flow range over which it applies. For use over extended flow ranges and for non-linear devices, multiple K-factors will be specified, often in a table similar to the one shown below.

Flow Rate Litres/minute	K-factor Pulse/litre
5	200
10	230
15	239
20	242

From this calibration certificate information the output frequency of the flowmeter, which is required for conditioning the Rate Totaliser lineariser, can be calculated.

$$\text{Output frequency Hz} = \frac{(\text{Flow rate per min}) \times (\text{K-factor})}{60}$$

Flow Rate Litres/min	K-factor Pulses/litre	Output frequency Hz
0	0	0
5	200	16.66
10	230	38.33
15	239	59.75
20	242	80.66

7.2 Summary of lineariser configuration functions

This section summarises the lineariser configuration functions. When read in conjunction with Fig 11 it provides a quick aid for configuring each of the two linearisers. If more detail is required, each section contains a reference to a full description of the function.

The number of straight-line lineariser segments required should first be entered using the *R**D**D* and *d**E**L* functions. In both of these sub-functions the Rate Totaliser displays the current segment and the total number of segments being used as shown below.

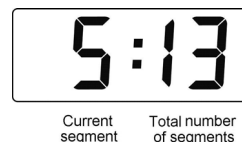

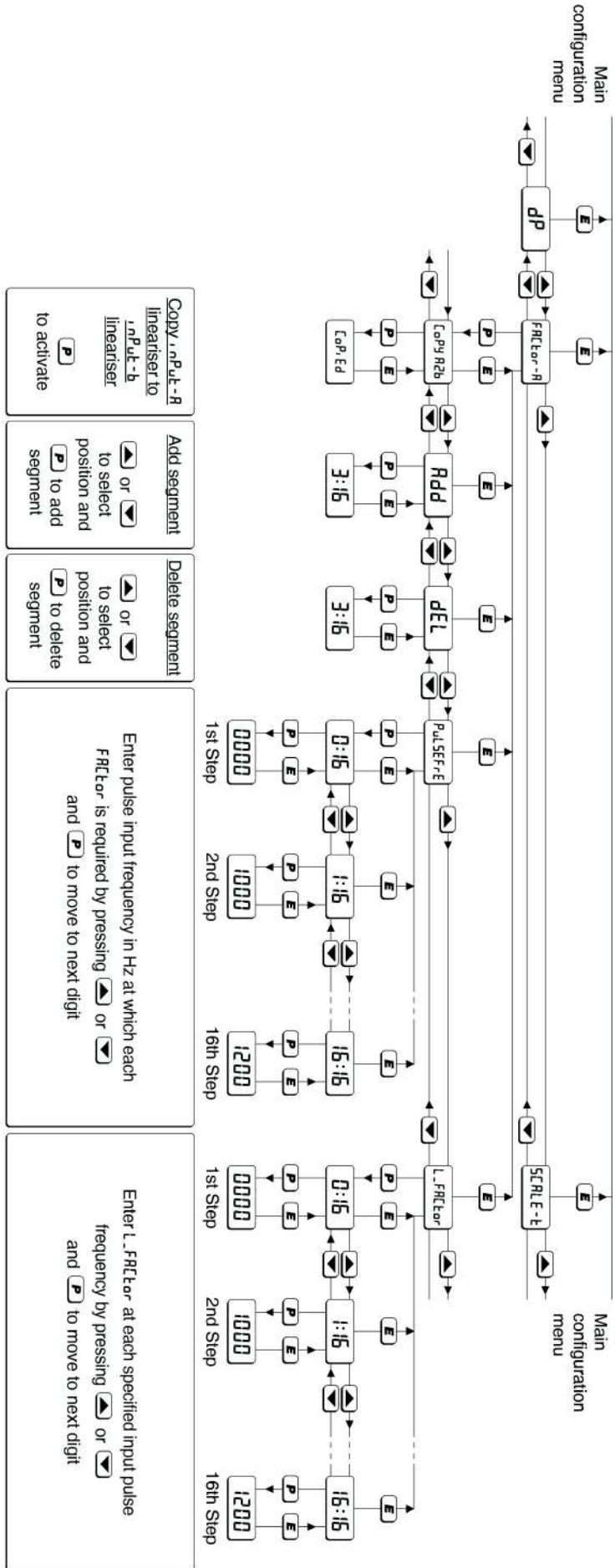

Fig 12 Lineariser configuration menu

Increasing the number of segments will provide a more accurate approximation of the flowmeter characteristic and increase totalisation accuracy.

Note: The pulse input frequency, $PULSE Fr$, of successive breakpoints must be monotonic i.e. the pulse input frequency must increase with breakpoint number. See 7.8

Display	Summary of function
---------	---------------------

[COPY] R2b Copy A lineariser configuration to b lineariser.

When the **[P]** push button is pressed the configuration of the A input lineariser is copied to the b input configuration lineariser.
See section 7.3

Rdd Add a segment

Adds a new segment before the displayed segment. The calibration of existing segments is not changed, but the identification number of all subsequent segments is increased by one.

See section 7.4

dEL Remove a segment

Removes the displayed segment, the identification number of all subsequent segments is decreased by one.

See section 7.5

PULSE Fr Pulse input frequency

Defines the input frequency in Hz at which the selected lineariser segments starts.

See section 7.6

L_FACTOR Flowmeter K-factor

The rate totaliser pulse input is divided by **L_FACTOR**, which is usually set to the K-factor of the flowmeter, thus converting the flowmeter output into engineering units. **L_FACTOR** may be adjusted between 0.0001 and 99999. Up to 16 values for **L_FACTOR** may be entered, each at a specified input pulse frequency.

See section 7.7

Note: The following detailed description of the lineariser configuration functions refer to the input A lineariser. The Input b lineariser has separate identical functions.

7.3 Copy A lineariser configuration to b lineariser: [COPY] R2b

When both inputs of the BA384G Rate Totaliser are connected to separate flowmeters with the same non-linearity, this sub-function simplifies configuration by copying input A lineariser configuration to the input b lineariser so that the information only has to be entered once.

Select **FRCTOR-R** in the configuration menu and press **[P]**, which will reveal one of five sub-functions. If **[COPY] R2b** is not displayed, repeatedly press the **[V]** or **[A]** button to select **[COPY] R2b**. Pressing the **[P]** button will initiate the copy, when complete the instrument will display **[dP] Ed** followed by the **[COPY] R2b** prompt from which another sub-function may be selected, or pressing the **[E]** button will return the instrument to the configuration menu.

7.4 Add a segment: Rdd

Rdd is a sub-function in the **FRCTOR-R** function that enables a straight-line segment to be added to the lineariser at any point. Select **FRCTOR-R** in the configuration menu and press **[P]**, which will reveal one of five sub-functions. If **Rdd** is not displayed, repeatedly press the **[V]** or **[A]** button to select **Rdd** followed by **[P]** which will display the current segment and the total number of segments as shown below:



Each time the **[P]** push button is operated a segment will be added to the lineariser. If configuring the lineariser for the first time, repeatedly press **[P]** until the required total number of segments is shown on the right hand side of the display. Any number between 1 and 16 may be selected.

If adding an additional segment to an already configured lineariser, the insertion position, which is shown on the left hand side of the display, can be selected using the **[V]** or **[A]** push button. When inserting an additional segment, the identification numbers of all segments equal to and above the insertion point are increased by one.

An additional segment may be placed below segment 0:n providing the frequency at which segment 0:n starts is greater than zero.

To return to the **Rdd** prompt in the **FRCTOR-R** sub-menu press **[E]**.

7.5 Remove a segment: ΔEL

ΔEL is a sub-menu in the $FRE\text{TOR}-R$ function that enables any segment to be removed from the lineariser configuration. To remove a segment, select $FRE\text{TOR}-R$ in the configuration menu and press P , which will reveal one of five sub-functions. If ΔEL is not displayed, repeatedly press the \blacktriangledown or \blacktriangle button to select ΔEL followed by P which will display the current segment and the total number of segments as shown below:

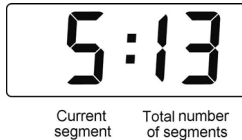

Each time the P push button is operated the current segment will be deleted from the lineariser. If configuring the lineariser for the first time, repeatedly press P until the total number of segments is reduced to the required number.

If removing a segment from a configured lineariser, the segment to be deleted, which is shown on the left hand side of the display, can be selected using the \blacktriangledown or \blacktriangle push button. When a segment is deleted, the identification numbers of all segments above the deleted segment are decreased by one.

To return to the ΔEL prompt in the lineariser sub-menu press E .

7.6 Input frequency: $PULSE Fr$

$PULSE Fr$ is a sub-menu in the $FRE\text{TOR}-R$ function for entering the pulse input frequency at which each of the lineariser segments starts, see Fig 12.

To enter the input pulse frequency at which a lineariser segment starts, select $FRE\text{TOR}-R$ in the configuration menu and press P , which will reveal one of four sub-functions. If $PULSE Fr$ is not displayed press the \blacktriangledown or \blacktriangle button repeatedly to select $PULSE Fr$ followed by P to display the current segment for which the start frequency will be entered and the total number of segments that have already been defined using the Rdd and ΔEL functions, see below.

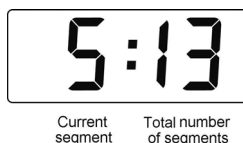

The required segment, which is shown on the left hand side of the display, can be selected using the \blacktriangledown or \blacktriangle push buttons. When selected press

P which will reveal the current input frequency with one digit flashing. The value of the flashing digit may be changed by pressing the \blacktriangledown or \blacktriangle button. When this digit is correct pressing P will transfer control to the next digit. When the input frequency for this lineariser segment is set as required, press the E button to return to the segment identification display from which the next segment may be selected using \blacktriangledown or \blacktriangle push buttons. When the input frequency for all of the segments has been entered, return to the $FRE\text{TOR}-R$ prompt in the configuration menu by operating the E push button.

7.7 Flowmeter K-factors: $L_FRE\text{TOR}$

$L_FRE\text{TOR}$ is a sub-menu in the $FRE\text{TOR}-R$ function for entering the flowmeter K-factor for each of the lineariser segments, see Fig 12.

The rate totaliser pulse input is divided by $L_FRE\text{TOR}$ which is adjustable between 0.0001 and 99999; for flow applications it should be set to the K-factor of the flowmeter. K-factor is the number of pulses that the flowmeter produces per unit volume of flow e.g. 20 pulses per litre. $L_FRE\text{TOR}$ therefore converts the flowmeter output into engineering units ready for further scaling to produce the required rate and total flow displays.

To enter the flowmeter K-factor for one or more segments, select $FRE\text{TOR}-R$ in the configuration menu and press P , which will reveal one of four sub-functions. If $L_FRE\text{TOR}$ is not displayed in the sub-menu repeatedly press the \blacktriangledown or \blacktriangle button to select $L_FRE\text{TOR}$ and followed by P to display the current segment for which $L_FRE\text{TOR}$ will be entered. The required segment, which is shown on the left hand side of the display, can be selected using the \blacktriangledown or \blacktriangle push button, see below.

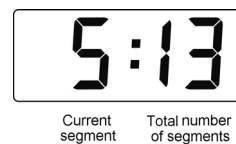

When selected, press P which will reveal the current $L_FRE\text{TOR}$ for the selected segment with one digit flashing. The value of the flashing digit may be changed by pressing the \blacktriangledown or \blacktriangle button. When this digit has been adjusted as required, pressing P will transfer control to the next digit. When all the digits have been adjusted pressing P will transfer control to the decimal point that may be positioned between any of the digits, or may be omitted by moving it to the right of the least significant digit.

When $L_FRE\text{TOR}$ for this lineariser segment is set as required, press the E button to return to the segment identification display from which the next

segment may be selected using \blacktriangledown or \blacktriangleleft push button. When $L_FRACtor$ for all of the segments has been entered, return to the $FRACtor-R$ prompt in the configuration menu by operating the E push button twice.

7.8 Lineariser error message

If an attempt is made to position a segment at an input frequency which is not greater than the frequency of the preceding segment, or at an input frequency which is not less than the frequency of the following segment, the error message $URLUE.ERR$ will be displayed.

To avoid generating an error it may be easier to enter the bottom and top frequencies first and then insert new break points between them.

7.9 Lineariser factory defaults

The linearisers factory defaults are two breakpoints, producing one segment starting at 0Hz and finishing at 5000Hz with an $L_FRACtor$ of 1.0.

Break point	PULSE Fr	L_FRACtor
0:1	0Hz	1.00
1:1	5000Hz	1.00

8. PULSE OUTPUT

The BA384G Rate Totaliser has an opto-isolated pulse output with the following electrical parameters:

R_{on}	=	$60\Omega + 3V$
R_{off}	=	$1M\Omega$
I_{max}	=	$10mA$

The output pulse may be a synchronous duplicate of pulse input A or pulse input b for re-transmission applications, or it may be derived from the least significant digit of the composite total display. When derived from the composite total display the output pulse frequency may be divided and the output pulse width defined.

The retransmitted RTx annunciator on the instrument display shows the status of the retransmitted pulse output. Annunciator activation depends upon the setting of $SOURCE$ in the pulse output configuration menu.

SCALE:

Annunciator activated each time pulse output open collector is on, i.e. R_{on} is less than $60\Omega + 3V$.

dirECT:

Annunciator continuously activated

8.1 Intrinsic safety

The pulse output is an optically isolated separate intrinsically safe circuit that has zero output safety parameters. The output therefore complies with the requirements for *simple apparatus*. This allows pulse output terminals P1 and P2 to be connected to any intrinsically safe circuit protected by a certified Zener barrier or galvanic isolator providing the output parameters do not exceed:

U_o	\leq	$28V$ dc
I_o	\leq	$200mA$ dc
P_o	\leq	$0.84W$

The equivalent capacitance and inductance of the pulse output are both zero which allows the maximum permissible cable parameters specified by the certificate for the Zener barrier or galvanic isolator powering the pulse output circuit to be used.

8.2 System design

The Rate Totalisers pulse output is a passive circuit i.e. unpowered open collector, but it is totally isolated from all other Rate Totaliser circuits. Subject to complying with intrinsic safety interconnection requirements defined in section 8.1, the terminals P1 and P2 may be connected to another instrument that can accept an open collector input. The pulse output may also be transferred to the safe area via a galvanic isolator or a Zener barrier.

Fig 13 shows how a 2-channel Zener barrier may be used to produce a voltage pulse in the safe area that could be connected to counter. The positive terminal of the pulse output circuit P1 is connected to the Rate totaliser's positive supply terminal 1 at the Rate Totaliser. When an output pulse occurs and the open collector 'closes', P2 is connected to P1 and a pulse current flows through the diode return barrier to resistor R1 in the safe area. The current flowing in the circuit is defined by resistor R1 which should be chosen to limit the pulse current to less than 10mA. For a 24V supply R1 should be greater than 2,200Ω

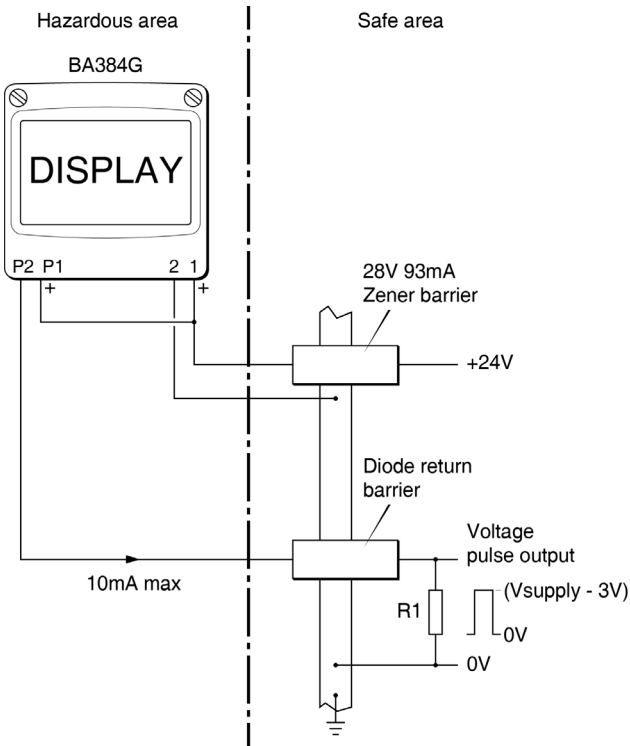

Fig 13 Transferring pulse output to safe area using a Zener barrier.

8.3 Configuration

The pulse output sub-menu is accessed via the **PULSE oP** function in the configuration menu. The pulse output sub-menu allows the source of the output pulse to be selected in the **Source** sub-function. For re-transmission applications the output pulse may be a duplicate of one of the input pulses by selecting **direct-R** or **direct-b** in the **Source** sub-function. Alternatively, selecting **SCALEd** derives the output pulse from incrementation of the least significant digit of the composite total display input A+ input b.

Note: The **SCALEd** function is not available when the composite total is **input R - input b**.

When **SCALEd** is selected two additional functions, **divide** and **duration** are added to the sub-menu allowing the output pulse frequency to be divided and the output pulse width (duration) to be defined – see Fig 14.

8.4 Access Pulse output sub-menu: PULSE.oP.

Access the Rate Totaliser configuration menu as described in section 6.2. Using the \blacktriangledown or \blacktriangle push buttons scroll through the menu until **PULSE.oP** is displayed, pressing **P** will then access the pulse output sub-menu which is shown in Fig 14.

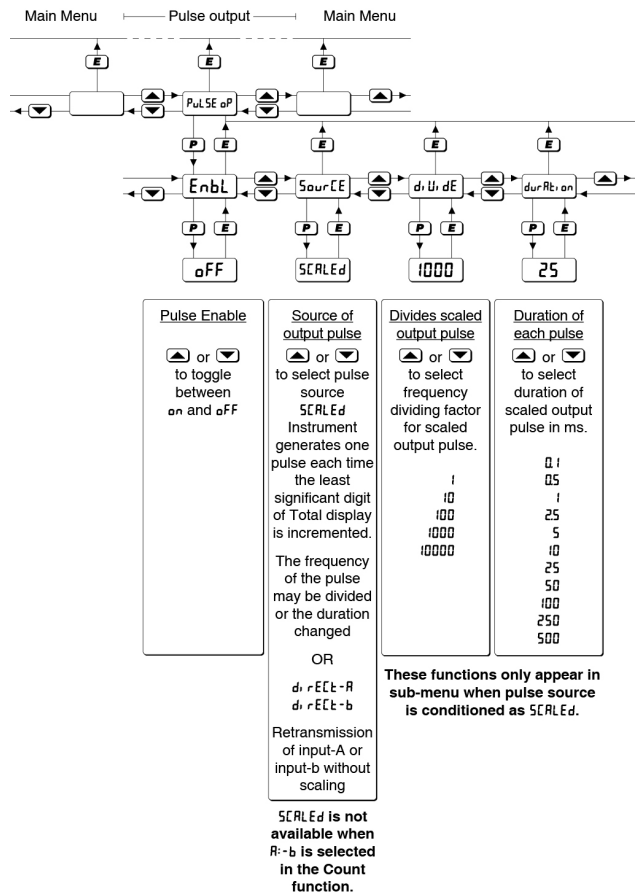

Fig 14 Pulse output configuration sub-menu

8.5 Enable pulse output: E_{nbl}

This function allows the pulse output to be disabled or enabled without altering any of the pulse output parameters. Using the \blacktriangledown or \blacktriangle push button select E_{nbl} in the pulse output sub-menu and press P to reveal the existing setting on or off . The function can be changed by pressing the \blacktriangledown or \blacktriangle push button followed by the E button to return to E_{nbl} prompt.

8.6 Source of output pulse: 5_{ourCE}

The output pulse may be derived from:

$d, rEEt-A$ **Rate Totaliser input-A pulse.**
Output is a duplicate of input-A pulse.

$d, rEEt-b$ **Rate Totaliser input pulse-b**
Output is a duplicate of input-b pulse.

$5[R]LEd$ **Composite total**
Input A+b which is defined by the $Count$ function in the configuration menu.

A pulse output occurs each time the least significant digit of the composite total is incremented. The frequency of the pulse output may be divided and width defined by functions d, U, dE and $dURRt, on$ which are only available when $5[R]LEd$ is selected.

Note: When input A – input b $R-b$ is selected in the Count function, the scaled pulse output $5[R]LEd$ is not available.

Using the \blacktriangledown or \blacktriangle push button select 5_{ourCE} in the pulse output sub-menu and press P to reveal the existing pulse source. The function can be changed by pressing the \blacktriangledown or \blacktriangle push button followed by the E button to return to 5_{ourCE} prompt.

8.7 Divide output pulse frequency: d, U, dE

When the output pulse is derived from the least significant digit of the composite total, the output pulse frequency may be divided by:

1
10
100
1000
10000

Using the \blacktriangledown or \blacktriangle push button select d, U, dE in the pulse output sub-menu and press P to reveal the existing divisor. The value can be changed by pressing the \blacktriangledown or \blacktriangle push button to select the required value followed by the E button to return to d, U, dE prompt.

Note: This function only appears in the pulse output sub-menu when the output pulse is derived from the composite total.

8.8 Output pulse width: *durRate on*

When the output pulse is derived from the least significant digit of the composite total, the output pulse width in milliseconds is defined by this function. One of 11 pulse widths may be selected:

0.1
0.5
1
2.5
5
10
25
50
100
250
500

Using the \blacktriangledown or \blacktriangle push button select *durRate on* in the pulse output sub-menu and press P to reveal the existing pulse duration. The value can be changed by pressing the \blacktriangledown or \blacktriangle push button to select the required value followed by the E button to return to *durRate on* prompt.

Note: This function only appears in the pulse output sub-menu when the output pulse is derived from the least significant digit of the total display.

8.9 Stored pulses

If the *dL*, *dE* and *durRate on* functions are configured such that the output pulse frequency with the specified pulse width can not be output in real time, the number of pulses will be stored and transmitted at the maximum possible speed.

When total-A or total-b are reset to zero, any stored pulses which have yet to be transmitted will be discarded.

Stored pulses which have yet to be transmitted will not be retained when the BA384G Rate Totaliser power supply is interrupted.

9. CONFIGURATION EXAMPLE

In this example a BA384G Rate Totaliser is required to display the total rate of flow, the total flow and the sum of the flow rate and total in two pipes. Identical flowmeters are fitted in each pipe which have a K-factor of 105 pulses per litre with a magnetic pick-off output.

The BA384G is required to display rate of flow in imperial gallons per hour with a resolution of one gallon and total flow in cubic metres with a maximum total of 100000 and a resolution of 0.01 cubic metres. Linearisation is not required. Totalisation is to stop when the flow rate on each input falls below 10 gallons per hour. The display is to be updated twice per second.

For this application the operator needs to reset the total display to zero from the totalising mode, but should not be able to reset the grand total. To prevent tampering the instrument configuration menu is to be protected by security code of 1209

9.1 Configuration procedure

The BA384G Rate Totaliser may be configured on-site without disconnection from the power supply or from the flowmeters.

Step 1 Enter the configuration menu

Enter the configuration menu by simultaneously pressing P and E . Assuming a security code has not already been entered the instrument will respond by displaying *FuncRate on* which is the first function in the configuration menu.

See Fig 10.

Step 2 Select a linear function

With *FuncRate on* displayed press P to reveal the function of the Rate Totaliser. Using the \blacktriangledown or \blacktriangle button select *Std* to switch off the linearisers and provide a linear function. Press E to enter the selection. See 6.4

Step 3 Select the type of input & debounce

Using the \blacktriangledown or \blacktriangle button select *input-R* in the configuration menu and press P which will reveal the sub-menu. Again using the \blacktriangledown or \blacktriangle button select *input* and press P to reveal the current input. The Rate Totaliser is required to work with a magnetic pick-off so using the \blacktriangledown or \blacktriangle button select *pick-off* followed by E to return to the *input* prompt in the sub-menu.

Using the \blacktriangledown or \blacktriangle button select $dEbounEE$ from the sub-menu and press P . Using the \blacktriangledown or \blacktriangle button select $dEFRuLt$ which will provide moderate noise protection. If the Rate Totaliser is subsequently found to miscount the noise rejection can be increased. Enter the selection and return to the $i, nPuL-R$ prompt in the configuration menu by pressing the E button twice. As both flowmeters are the same repeat for input b using the $i, nPuL-b$ function. See 6.6 and 6.7

Step 4 Select the interval between display updates.

Using the \blacktriangledown or \blacktriangle button select $uPdRE$ in the configuration menu and press P to reveal how frequently the Rate Totaliser display is updated. Using the \blacktriangledown or \blacktriangle push button select 0.5 (0.5 seconds i.e. 2 display updates per second). Enter the selection and return to the $uPdRE$ prompt in the configuration menu by pressing the E button. See 6.8

Step 5 Count

Using the \blacktriangledown or \blacktriangle button select Count in the configuration menu and press P to reveal the existing arithmetic relationship between input A and input b. In this example the Rate Totaliser is required to display the sum of the two inputs, therefore using the \blacktriangledown or \blacktriangle push button select $A+b$. Enter the selection and return to the Count prompt in the configuration menu by pressing the E button. See 6.9

Step 6 Upper display

Using the \blacktriangledown or \blacktriangle button select $d, 5P-1$ in the configuration menu and press P to select whether flow rate or flow total is shown on the upper 8 digit display. The required maximum total of 100000 with 0.01 resolution can only be accommodated on the top eight digit display. Using the \blacktriangledown or \blacktriangle button select $totRL$ and press E to enter the selection and return to the $d, 5P-1$ prompt in the configuration menu. See 6.10

Step 7 Lower display

Using the \blacktriangledown or \blacktriangle button select $d, 5P-2$ in the configuration menu and press P to select if the lower display function. The Rate Totaliser is required to display both total flow and the rate of flow so the lower display is required. Using the \blacktriangledown or \blacktriangle button select $5td$ and press E to enter the selection and return to the $d, 5P-2$ prompt in the configuration menu. See 6.11

Step 8 Position rate & total decimal points

Select dP from the configuration menu and press P . The upper display already defined as the total display by function $d, 5P-1$ will be activated and identified by the Total annunciator. Using the \blacktriangledown or \blacktriangle push button position the decimal point in front of the second least significant digit to give a total display resolution of 0.00.

Pressing the P button will show the rate display, but in the upper display position with the Rate annunciator activated. Using the \blacktriangledown or \blacktriangle push button position the decimal point to the right of the least significant digit so that it is not visible to give a total display resolution of 1.

Finally press the E button to enter the selections and return to the dP prompt in the configuration menu. See 6.12

Step 9 Enter the flowmeter K-factor

K-factor is the number of pulses that a flowmeter produces per unit volume of flow. The Rate Totaliser pulse input A is divided by $FR[tor-R]$, which is adjustable between 0.0001 and 99999; when set to the K-factor of the flowmeter it converts the flowmeter output into engineering units ready for further scaling to produce the required rate and total flow displays

Using the \blacktriangledown or \blacktriangle push button select $FR[tor-R]$ from the configuration menu and press P to show the existing value with one digit flashing. This should be changed to 105 using the \blacktriangledown and \blacktriangle push buttons to adjust the flashing digit and the P button to transfer control to the next digit and to position the decimal point.

Finally, enter the new figure and return to the *FREtOr-R* prompt in the configuration menu by pressing **(E)**. The output from FACtor-A will now be in litres which may be scaled to produce required rate and total displays.

Repeat for input b using the *FREtOr-b* function.
See 6.13

Step 10 Enter the total scale factor

The Total Scale Factor *SCALE.t-R* is a dividing factor adjustable between 0.0001 and 99999 that enables total flow to be displayed in the required engineering units. In this example the total flow display is required in cubic metres. There are 1,000 litres in a cubic metre so *SCALE.t-R* should be set to 1000.

Using the **(V)** or **(A)** push button select *SCALE.t-R* from the configuration menu and press **(P)** to reveal the existing value with one digit flashing. This should be changed to 1000 using the **(V)** or **(A)** push button to adjust the flashing digit and the **(P)** button to transfer control to the next digit and to position the decimal point. Finally, enter the new value and return to the *SCALE.t-R* prompt in the configuration menu by pressing **(E)**.

The total flow display is independent of the rate display.

Repeat for input b using the *SCALE.t-b* function.

See 6.14

Step 11 Enter the rate scale factor

SCALE.r-R is a dividing factor adjustable between 0.0001 and 99999 that enables the input A flow rate to be displayed in the required engineering units. The rate display timebase is determined by 't-bR5E that is adjusted in Step 12.

In this example the rate of flow display is required in imperial gallons. *FREtOr-R*, which was adjusted in Step 8, has an output in Litres that must be converted to imperial gallons. There are 4.5461 Litres in an imperial gallon therefore *SCALE.r-R* should be adjusted to 4.5461

Using the **(V)** or **(A)** push button select *SCALE.r-R* from the configuration menu and press **(P)** to reveal the existing value with one digit flashing.

This should be changed to 4.5461 using the **(V)** or **(A)** push button to adjust the flashing digit and the **(P)** button to transfer control to the next digit and to position the decimal point. Finally, enter the new value and return to the *SCALE.r-R* prompt in the configuration menu by pressing **(E)**.

The flow rate display is independent of the total flow display.

Repeat for input b using the *SCALE.r-b* function.

See 6.15

Step 12 Enter the rate timebase

The rate timebase determines if rate is displayed per second, per minute or per hour. In this example gallons per hour are required. Using the **(V)** or **(A)** push button select t-bR5E from the configuration menu and press **(P)**. Again using the **(V)** or **(A)** push button select t-b-3600 from the three options which will multiply the rate display by 3600. Enter the selection and return to the t-bR5E prompt in the configuration menu by pressing **(E)**.

See 6.16

Step 13 Adjust the display filter

The digital display filter has two independent adjustable parameters enabling the rate display response to be tailored for optimum performance. The filter parameters are controlled by a two digit number. The first digit defines the amount of filtering applied to the display, for initial configuration it is recommended it is set to 2 which is a time constant of 4.3 seconds. The second digit controls jump-out following a step input change and it is recommended that this is initially set to 0.

After configuration during commissioning both parameters should be adjusted experimentally to provide a stable display with an acceptable step response. To allow the effect of filter changes to be seen immediately, the live rate display is shown on the lower display while the filter parameters are shown and may be adjusted on the upper display.

Using the \blacktriangledown or \blacktriangle push button select $F, LLEr-R$ from the configuration menu and press P . The first digit, which controls the filter time constant, will be flashing and should be set to 2 using the \blacktriangledown or \blacktriangle push button. The P button will transfer control to the second digit, which controls the step response and should be set to 0 in the same way. Finally, enter the selection and return to the $F, LLEr$ prompt in the configuration menu by pressing E .

Repeat for input b using the $F, LLEr-b$ function.
See 6.17

Step 14 Define clip-off

To prevent totalisation of low flow rates clip-off defines an adjustable flow rate threshold below which totalisation is inhibited. In this example it is required that totalisation does not occur at flow rates below 10 gallons per hour on each input.

Using the \blacktriangledown or \blacktriangle push button select $[LP, OFF-R$ from the configuration menu. Press P which will reveal the existing clip-off threshold in gallons per hour i.e. the same units already selected for the rate display. Change the display to 10 using the \blacktriangledown or \blacktriangle push buttons to adjust the flashing digit and the P button to transfer control to the next digit. Finally, enter the new clip-off threshold and return to the $[LP, OFF-R$ prompt in the configuration menu by pressing E .

Repeat for input b using the $[LP, OFF-b$ function.
See 6.18

Step 15 Local reset of total and grand total

Two separate functions in the $L0[[Lr$ sub-menu may be individually activated to allow the operator to reset the individual totals and the composite grand total displays from the totalising mode without entering the configuration menu.

In this example the operator is required to reset the total displays but not the composite grand total display when the BA384G Rate Totaliser is in the totalising mode.

Using the \blacktriangledown or \blacktriangle button select $L0[[Lr$ in the configuration menu and press P which will reveal the sub-menu. Again using the \blacktriangledown or \blacktriangle button select the local total reset function $[Lr tot$ and press P . This is required so using the \blacktriangledown or \blacktriangle button select on followed by E to return to the $[Lr tot$ prompt in the sub-menu.

Using the \blacktriangledown or \blacktriangle button select the local grand total reset function $[Lr gtot$ and press P . This is not required so using the \blacktriangledown or \blacktriangle button select off . Enter the selection and return to the $L0[[Lr$ prompt in the configuration menu by pressing the E button twice.
See 6.20 and 6.21

Step 16 Reset the grand total to zero

Before completing configuration, the Rate Totaliser's composite grand total should be reset to zero. Using the \blacktriangledown or \blacktriangle button select $[Lr, gtot$ in the configuration menu and press P which will cause $[Lr, no$ to be displayed. Again using the \blacktriangledown or \blacktriangle button select $[Lr YES$ and press P which will result in a 0000 display with one digit flashing. This is a request for the instruction to be confirmed by entering 5urE using the \blacktriangledown or \blacktriangle buttons to set each digit and the P button to move control to the next digit.

Pressing **[E]** will then reset the composite grand total to zero and return the instrument to the **CLr. tEtEt** prompt in the configuration menu.
See 6.23

Step 17 Define the security code

Defining a security code prevents unauthorised access to the configuration menu. Using the **[v]** or **[^]** buttons select **Code** from the configuration menu and press **[P]** which will reveal **0000** with the first digit flashing. This example requires the security code to be 1209. Using the **[v]** or **[^]** buttons set the flashing digit to **1** and press **[P]** to transfer control to the second digit. When all have been entered press **[E]** to return to the configuration menu.
See 6.24

Step 18 Return to the totalising mode

Configuration of the BA384G is now complete. Pressing the **[E]** button will save the new configuration and return the Rate Totaliser to the totalising mode. The BA384G will display **Rate** followed by **Sum** while the new information is stored in permanent memory, which will be protected from unauthorised adjustment by the security code.

In the totalising mode, operating the **[v]** or **[^]** button will scroll the BA384G display between Input-A, Input-b and the composite display Input-A + Input-b.

10. MAINTENANCE

10.1 Fault finding during commissioning

If a BA384G fails to function during commissioning the following procedure should be followed:

Symptom	Cause	Check:
No display	No power supply, or incorrect wiring. Note: Terminals 2, 6, 10 & RS2 are interconnected within the instrument.	That there is between 10 and 28V on terminals 1 & 2 with terminal 1 positive.
Rate Totaliser is receiving power but flow indicator is not rotating when either input is selected.	No input pulses, or incorrect input configuration	Input configuration. Correct linking of terminals 3 & 4 for input A and terminals 7 & 8 for input b. Input pulses have correct polarity.
Flow indicator rotating, but incorrect rate display on one or both inputs.	Incorrect rate display calibration.	<i>Rate - A</i> <i>Rate - b</i> <i>Rate - A</i> <i>Rate - b</i> <i>Rate</i>
Flow indicator rotating, but incorrect total display.	Incorrect total display calibration. Remote reset switch contacts are closed.	<i>Rate - A</i> <i>Rate - b</i> <i>Rate - A</i> <i>Rate - b</i> If reset annunciator is activated, check reset wiring and switch.
Unstable rate display.	Noisy pulse input signal.	Eliminate electrical noise. Increase input de-bounce and/or display filter.
Alarms do not function.	Alarms have been automatically disabled following rate display recalibration.	Enable both alarm outputs.
Unable to enter configuration menu.	Incorrect security code	That the correct security code is being used. Contact BEKA if code is lost.

10.2 Fault finding after commissioning

ENSURE PLANT SAFETY BEFORE STARTING MAINTENANCE

Live maintenance is permitted on intrinsically safe equipment installed in a hazardous area, but only certified test equipment should be used unless a gas clearance certificate is available.

If a BA384G fails after it has been functioning correctly, the following table may help to identify the cause of the failure.

Symptom	Cause	Check:
No display	No power supply	That there is between 10 and 28V on terminals 1 & 2 with terminal 1 positive.
Flow indicator not rotating on one or both inputs.	No input pulses	Output from flowmeter. Wiring between flowmeters and BA384G.
Flow indicator rotating. HOLD annunciator activated.	Input is below clip-off threshold	CLIFF threshold and adjust if necessary.
Unable to enter configuration menu.	Incorrect security code	That the correct security code is being used. Contact BEKA if code is lost.

If this procedure does not reveal the cause of the fault, it is recommended that the instrument is replaced.

10.3 Servicing

We recommend that faulty BA384G rate totalisers are returned to BEKA associates or to your local BEKA agent for repair.

10.4 Routine maintenance

The mechanical and electrical condition of the instrument should be regularly checked. Inspection frequency should be adjusted to suit the environmental conditions.

10.5 Guarantee

Instruments which fail within the guarantee period should be returned to BEKA associates or your local BEKA agent. It is helpful if a brief description of the fault symptoms is provided.

10.6 Customer comments

BEKA is always pleased to receive comments from customers about our products and services. All communications are acknowledged and whenever possible, suggestions are implemented.

11. ACCESSORIES

11.1 Units of measurement & instrument identification.

New BA384G Rate Totalisers are supplied with a printed scale card showing the units of measurement and tag information specified when the instrument was ordered. If this information was not supplied a blank scale card will be fitted which can easily be marked with a dry transfer or a permanent marker on-site.

Custom printed scale cards are available as accessories and may be easily fitted as shown in section 5.4 of this manual.

The BA384G can also be supplied with a blank or custom laser engraved stainless steel legend plate - see Fig 7. The plate, which after installation is visible from the front of the instrument, is supplied loose with two fixing screws for securing it to the rear of the instrument's back-box. This plate can typically accommodate:

1 row of 5 alphanumeric characters 10mm high

or 1 row of 6 alphanumeric characters 7mm high

or 2 rows of 10 alphanumeric characters 5mm high

10.2 Backlight

The BA384G Rate Totaliser can be supplied with a factory fitted backlight that produce green illumination enhancing display contrast and enabling it to be read at night or in poor lighting conditions. The backlight is internally powered from the instrument so that no additional wiring or intrinsically safe interface is required, but the instrument supply current increases to 32mA.

11.3 Alarms

The BA384G can be supplied with factory fitted dual solid state single pole alarm outputs. These may be independently configured as high or low, rate or total alarms with normally open or normally closed outputs functioning on input A, input b, or on the calculated composite rate or total.

Configurable functions for each alarm include adjustable setpoint, alarm delay time and alarm silence time. Hysteresis may be applied to rate alarms.

CAUTION

These alarm outputs should not be used for critical safety applications such as a shut down system.

When the BA384G power supply is turned off or disconnected, alarm outputs will open irrespective of whether normally open or normally closed outputs have been selected. When designing a system an open output should therefore be chosen for the alarm condition.

Alarm annunciators on the instrument display indicate the status of both alarms. If an alarm delay or silence time has been selected the annunciator will flash during the delay or silence period. The BA384G internal counters are up-dated and compared with the alarm setpoint twice per second, irrespective of the display update time selected. This may result in an alarm being delayed for up to half a second after the rate or total has exceeded the setpoint.

11.3.1 Solid state output

Each alarm has a galvanically isolated single pole solid state switch output as shown in Fig 15. The outputs are polarised and current will only flow in one direction. Terminals A1 and A3 should be connected to the positive side of the supply.

$R_{on} = \text{less than } 5\Omega + 0.7V$

$R_{off} = \text{greater than } 1M\Omega$

Note: Because of the series protection diode some test meters may not detect a closed alarm output.

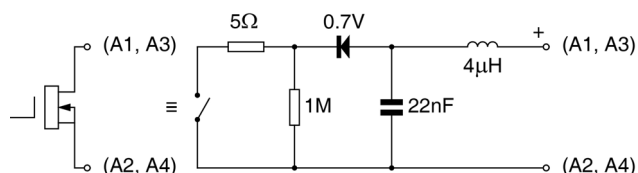

Fig 15 Equivalent circuit of each alarm output

11.3.2 Intrinsic safety

Each alarm output is a separate galvanically isolated intrinsically safe circuit with output safety parameters complying with the requirements for *simple apparatus*. This allows the alarm output terminals A1 & A2 and A3 & A4 to be connected to almost any intrinsically safe circuit protected by a Zener barrier or galvanic isolator providing the output parameters of the circuit do not exceed:

$U_o \leq 28V \text{ dc}$

$I_o \leq 200mA \text{ dc}$

$P_o \leq 0.84W$

The maximum equivalent capacitance and inductance between each set of alarm terminals is:

$$C_i = 22\text{nF}$$

$$L_i = 4\mu\text{H (Effectively 0)}$$

To determine the maximum permissible cable parameters C_i should be subtracted from the maximum permitted external capacitance C_o specified by the certificate for the intrinsically safe interface powering the alarm circuit, such as the solenoid driver or switch transfer galvanic isolators shown in Fig 16.

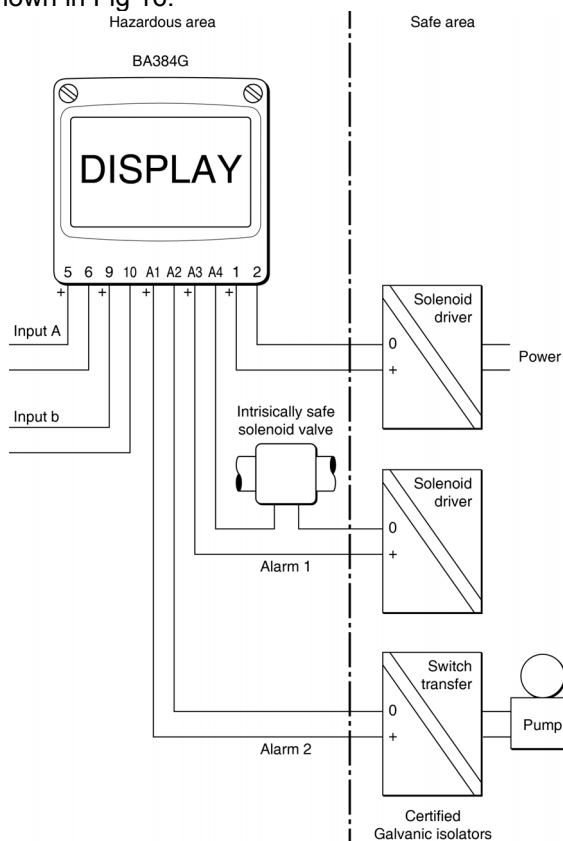

Fig 16 Typical alarm application

11.3.3 Configuration and adjustment

When a BA384G is supplied with alarms the configuration menu is extended as shown in Fig 17. The alarm functions appear after $E \ll r$, and each alarm may be configured to operate on the rate or total display of input A, input b or on the composite display input A+ input b or input A- input b.

For simplicity Fig 17 only shows the configurable functions on the rate option of alarm AL1, the total options are identical except that the total alarms can not have hysteresis. Alarm AL2 is identical to alarm AL1.

The following table summarises each of the alarm configuration functions and includes a cross reference to more detailed information. Again only the functions on alarm AL1 are listed.

Display Summary of function

EnbL Alarm enable
Enables or disables the alarm without changing the alarm configuration. See section 11.3.4

TYPE Type of alarm
Defines whether the alarm operates on the rate or total of input A, input b or the composite rate or total. See section 11.3.5

SP Ir-R Alarm setpoint
Adjusts the alarm setpoint. The alarm is activated when the rate or total display equals the setpoint.

Note: setpoints are identified as:

SP Ir-R Alarm 1, Rate, Input A
SP Ir-b Alarm 1, Rate, Input b
SP Ir Alarm 1, Rate (A+b or A-b)
SP It-R Alarm 1, Total, Input A
SP It-b Alarm 1, Total, Input b
SP It Alarm 1, Total (A+b or A-b)

Similarly for alarm 2 setpoints. See section 11.3.6

Hi.Lo Alarm function
Defines whether the alarm has a high or low function. See section 11.3.7

no.nC Normally open or normally closed output.
Determines whether the single pole alarm output is open or closed in the non-alarm condition. See section 11.3.8

HSt r Hysteresis
Adjusts the alarm hysteresis. Only available on a rate alarm. See section 11.3.9

dELR Alarm delay time
Adjusts the delay between the display equaling the setpoint and the alarm output being activated. See section 11.3.10

S, L Alarm silence time
Defines the time that the alarm output remains in the non-alarm condition following acceptance of an alarm. See section 11.3.11

Display Summary of function

FLSH **Flash display when alarm occurs**
 When enabled, alternates the rate or total display between process value and alarm reference RL 1 or RL2 when an alarm output is activated.
 See section 11.3.12

Display Summary of function

ACSP **Access setpoint**
 Sub-menu that enables access to the alarm setpoints from the totalising mode and defines a four digit access code.
 See section 11.3.13

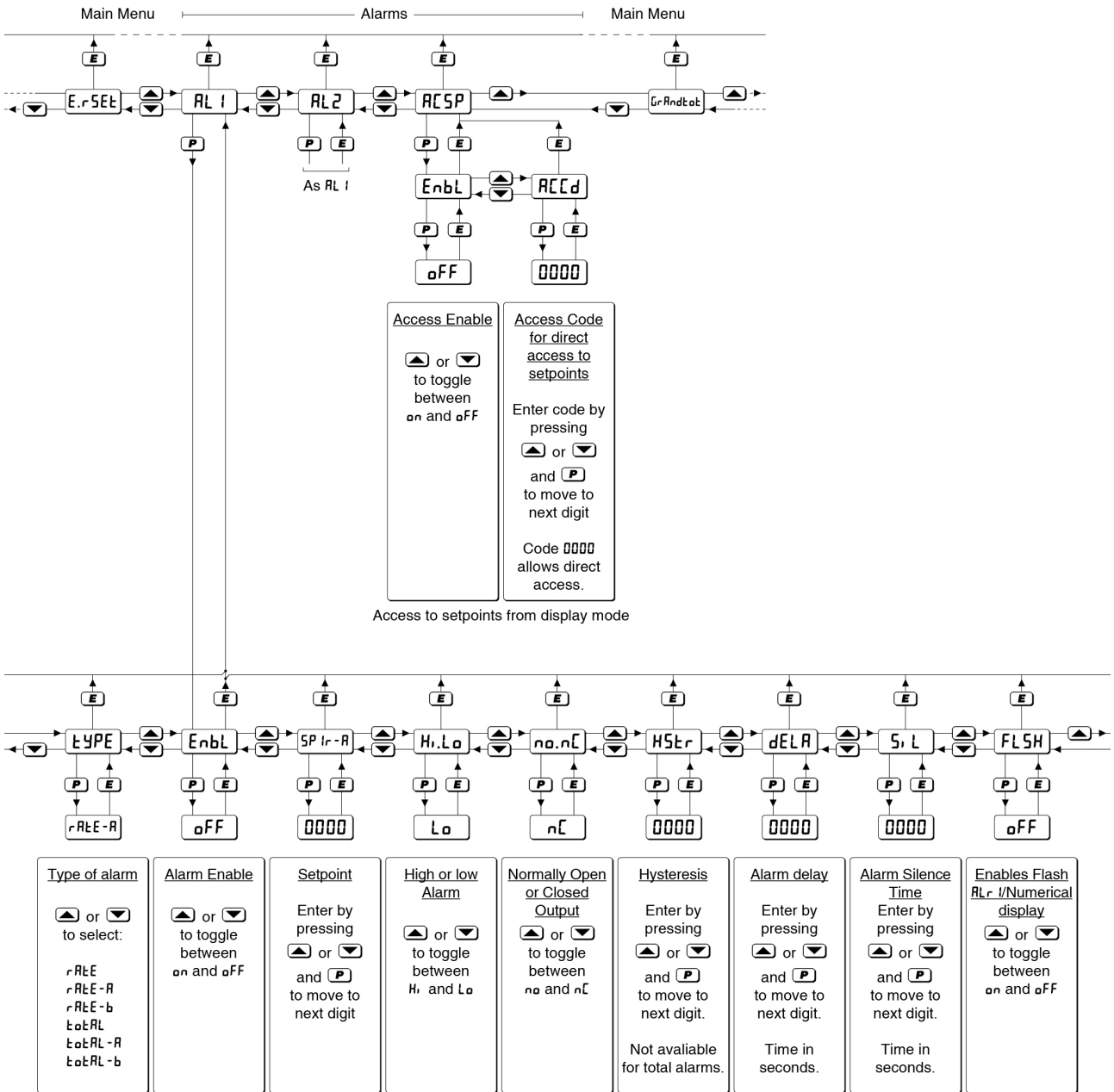

Fig 17 Alarm menu

11.3.4 Alarm enable: E_{nbl}

This function allows the alarm to be enabled or disabled without altering any of the alarm parameters. Using the \blacktriangledown or \blacktriangleleft push button select $RL1$ or $RL2$ from the configuration menu and press \mathbb{P} to reach E_{nbl} in the alarm sub-menu. Pressing \mathbb{P} will then reveal the existing setting. The function can be changed by pressing the \blacktriangledown or \blacktriangleleft push button followed by the \mathbb{E} button to return to the alarm sub-menu.

11.3.5 Type of alarm: $TYPE$

Alarm 1 and Alarm 2 are totally independent, both may be rate or total alarms, or one may be conditioned for rate and the other for total. Similarly both may function on input-A or Input-b or one may operate on input-A and the other on input-b. Using the \blacktriangledown or \blacktriangleleft push button select $TYPE$ from the selected alarm sub-menu and press \mathbb{P} to check or change the function. The \blacktriangledown or \blacktriangleleft push button will scroll through the following options:

$rRtE$	Alarm 1, Rate (A+b or A-b)
$rRtE-A$	Alarm 1, Rate, input A
$rRtE-b$	Alarm 1, Rate, input b
$tOtRtL$	Alarm 1, Total (A+b or A-b)
$tOtRtL-A$	Alarm 1, Total, Input A
$tOtRtL-b$	Alarm 1, Total, input b

When the required alarm has been selected press the \mathbb{E} button to enter the selection and return to the alarm sub-menu.

Alarm 2 has the same selectable options.

Note: When $TYPE$ is changed, the alarm configuration is automatically reset to the default values and the alarm is disabled. It must therefore be reconfigured before use.

11.3.6 Setpoint adjustment: $SP1$ - and $SP2$ -

The function of each alarm is determined by the $TYPE$ function, the setpoint name will change to reflect this selection. For example, if $rRtE-b$ was selected in the $TYPE$ function for alarm 1, the setpoint will be identified as $SP1r-b$.

Rate alarm setpoints may be positioned anywhere between -99999 and 999999; total alarm setpoints may be anywhere between -999999 and 9999999.

All setpoints are adjusted in the same way. Using the \blacktriangledown or \blacktriangleleft push button select the required setpoint in the alarm sub-menu and press \mathbb{P} which will reveal the existing setpoint value with one digit flashing.

The required setpoint can be entered using the \blacktriangledown or \blacktriangleleft push button to adjust the flashing digit and the \mathbb{P} button to transfer control to the next digit. When set as required press \mathbb{E} to enter the value and return to the setpoint prompt in the alarm sub-menu.

11.3.7 Alarm function: $Hi.Lo$

Alarm 1 and Alarm 2 are totally independent, both may be Hi or Lo, or one may be conditioned as a Hi alarm and the other as a Lo alarm. Using the \blacktriangledown or \blacktriangleleft push button select $Hi.Lo$ from the alarm sub-menu and press \mathbb{P} to check or change the function. The \blacktriangledown or \blacktriangleleft push button will toggle the alarm function between Hi and Lo, when set as required, press the \mathbb{E} button to return to the $Hi.Lo$ prompt in the alarm sub-menu.

11.3.8 Alarm output status: $no.nf$

Each single pole alarm output may be open or closed in the non-alarm condition. When the BA384G power supply is turned off or disconnected, the alarm outputs will open irrespective of whether normally open or normally closed outputs have been selected. Therefore, when designing an alarm system normally closed nf should be selected so that the output opens when an alarm occurs or if the power supply fails.

Using the \blacktriangledown or \blacktriangleleft push button select $no.nf$ from the selected alarm sub-menu and press \mathbb{P} to check or change the function. The \blacktriangledown or \blacktriangleleft push button will toggle the contact status between no and nf , when set as required, press the \mathbb{E} button to return to the $no.nf$ prompt in the alarm sub-menu.

11.3.9 Hysteresis: $H5tr$







Hysteresis is only available for rate alarms therefore the $H5tr$ function only appears in the configuration sub-menu when alarm $TYPE$ has been set to $rRtE-A$, $rRtE-b$ or $rRtE$. During configuration hysteresis is shown in the units of rate previously configured for the rate display.

Using the \blacktriangledown or \blacktriangleleft push button select $H5tr$ in the selected alarm sub-menu and press \mathbb{P} which will reveal the existing hysteresis with one digit flashing. The required hysteresis can be entered using the \blacktriangledown or \blacktriangleleft push button to adjust the flashing digit and the \mathbb{P} button to transfer control to the next digit. When set as required press \mathbb{E} to enter the value and return to the $H5tr$ prompt in the alarm sub-menu.

e.g. A BA384G configured to display a flow rate of 0 to 5000, with a high alarm set at 4000 and hysteresis of 100 will perform as follows: High alarm will be activated when flow rate increases to equal or exceed 4000, but will not reset until the flow rate falls below 3900.

11.3.10 Alarm delay: *dELR*

This function enables activation of the alarm output to be delayed for a fixed time following the alarm condition occurring. The delay can be set in 1 second increments up to 3600 seconds. If a delay is not required zero should be entered.







To adjust the delay select *dELR* using the  or  push button in the selected alarm sub-menu and press  which will reveal the existing delay time in seconds with one digit flashing. The required delay time can be entered using the  or  push button to adjust the flashing digit and the  button to transfer control to the next digit. When set as required press  to enter the value and return to the *dELR* prompt in the alarm sub-menu.

The alarm annunciator will start flashing immediately an alarm condition occurs and will continue for the delay time, after which the alarm output will be activated and the alarm annunciator will be permanently activated.

11.3.11 Alarm silence time: *S, L*

The alarm silence function is primarily intended for use in small installations where the alarm output directly operates an annunciator such as a sounder. When the alarm silence time is set to any figure other than zero, the BA384G Rate Totaliser  push button becomes an alarm accept button.

After an alarm has occurred, operating the  button will cause the alarm output to revert to the non-alarm condition for the configured alarm silence time. When an alarm is silenced the alarm annunciator will flash until the silence time expires.

To adjust the alarm silence time select *S, L* using the  or  push button in the selected alarm sub-menu and press  which will reveal the existing alarm silence time in seconds with one digit flashing. The required silence time can be entered using the  or  push button to adjust the flashing digit and the  button to transfer control to the next digit. When set as required press  to enter the value and return to the *S, L* prompt in the alarm sub-menu.







11.3.12 Flash display when alarm occurs: *FL5H*

In addition to the two alarm annunciators on the lower left hand side of the Rate Totaliser display which show the status of both alarms irrespective of which input is being displayed, this function provides an even more conspicuous indication that an alarm condition has occurred.



When enabled and the Rate Totaliser is displaying the input on which the alarm has occurred, the *FL5H* function alternates the rate or total display between the numerical value and the alarm identification. For example if alarm 1 has been









activated by a rate alarm occurring on input A the rate display will alternate between the numerical rate value and AL1, plus the input identification in - A if 5td has been selected for the lower display function *d, 5P-2* configuration – see 6.11.







Note: When an alarm occurs on one input the flash function will only be seen when viewing that input, not when the Rate Totaliser is showing the other input or the composite display. However, the two alarm annunciators, which indicate the status of each alarm, are activated irrespective of which input is being displayed.

To enable the function select *FL5H* from the alarm sub-menu using the  or  push button and press  to check or change the function. The  or  push button will toggle the function between *oFF* and *oN*, when set as required, press the  button to return to the *FL5H* prompt in the alarm sub-menu.

11.3.13 Access Setpoints: *RC5P*

This function activates a separate menu that provides direct access to the alarm setpoints from the totalising mode by simultaneously operating the  and  buttons. An operator can therefore adjust the alarm setpoints without having access to the configuration and alarm sub-menus. Protection against unauthorised or accidental adjustment is provided by a separate optional security access code.

Using the  or  push button select *RC5P* from the configuration menu and press  to reach the enable sub-function *EnbL*. Pressing  will reveal the existing setting which can be toggled between *oN* and *oFF* by pressing the  or  push button. When set as required, press the  button to return to the *EnbL* prompt from which a separate security access code can be entered using the *RC5P* sub-function which can be selected using the  or  push button.

To enter a new security access code select *RC5P* from the sub-menu and press  which will cause the Rate Totaliser to display *0000* with one digit flashing. The flashing digit may be adjusted using the  or  push buttons, when set as required operating the  button will transfer control to the next digit. When all the digits have been adjusted press  to return to the *RC5P* prompt. The revised security code will be activated when the Rate Totaliser is returned to the totalising mode. Default security access code *0000* will disable the security code allowing direct access to the setpoints in the totalising mode by pressing the  and  buttons simultaneously.

11.3.14 Adjusting alarm setpoints from the totalising mode.

Access to the two alarm setpoints from the Rate Totaliser totalising mode is obtained by operating the **[P]** and **[▲]** push buttons simultaneously as shown in Fig 18. If the setpoints are not protected by an access security code the alarm setpoint prompt **SP 1x** or **SP 2x** will be displayed depending upon whether a rate or total alarm has been conditioned. If the setpoints are protected by a security code, **Code** will be displayed first. Pressing **[P]** again will allow the alarm setpoint security code to be entered digit by digit using the **[▼]** or **[▲]** buttons to change the flashing digit and the **[P]** push button to move control to the next digit. If the correct code is entered pressing **[E]** will then cause alarm setpoint prompt **SP 1x** or **SP 2x** to be displayed. If an incorrect security code is entered, or a button is not pressed within ten seconds, the instrument will automatically return to the totalising mode.

Once within the menu pressing the **[▼]** or **[▲]** buttons will toggle the display between the two alarm setpoint prompts.

To adjust an alarm setpoint select the required alarm and press **[P]** which will reveal the existing value with one digit flashing. The flashing digit may be adjusted using the **[▼]** or **[▲]** push button followed by the **[P]** button to move control to the next digit. When the required setpoint has been entered, pressing **[E]** will return the display to the setpoint prompt from which the other setpoint may be selected, or the instrument may be returned to the totalising mode by pressing **[E]** again.

Note: Direct access to the alarm setpoints is only available when the menu is enabled - see section 11.3.13

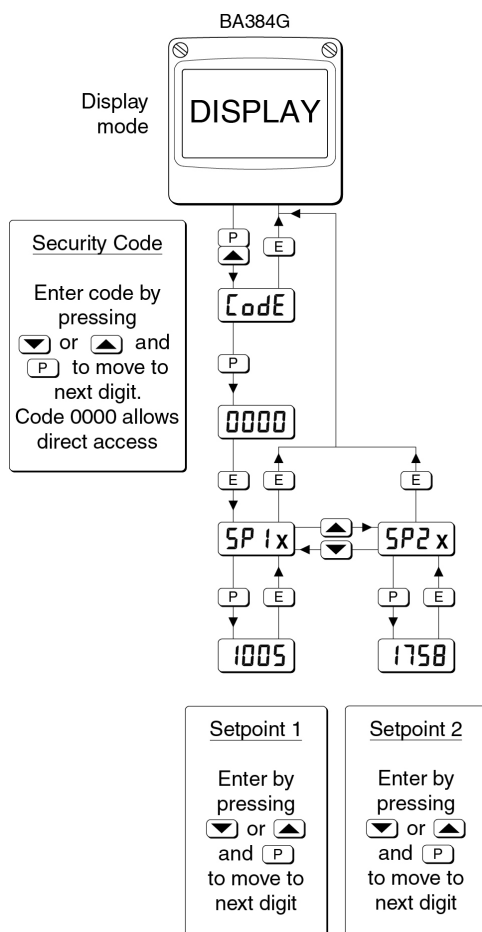

Fig 18 Setpoint adjustment from the totalising mode

11.4 4/20mA output

The BA384G Rate Totaliser can be supplied with a factory fitted galvanically isolated 4/20mA current sink output which may be conditioned to represent the composite rate or total display.

11.4.1 Intrinsic safety

The 4/20mA output has been certified as a separate galvanically isolated intrinsically safe circuit complying with the requirements for simple apparatus. This allows terminals C1 and C2 to be connected to any intrinsically safe circuit protected by a certified Zener barrier or galvanic isolator providing the output parameters do not exceed:

Uo	≤	28V dc
Io	≤	200mA dc
Po	≤	0.84W

The maximum equivalent capacitance and inductance of the 4/20mA output is:

Ci	=	2.2nF
Li	=	4µH

To determine the maximum permissible cable parameters, these figures should be subtracted from the maximum cable capacitance and inductance specified by the certificate for the Zener barrier or galvanic isolator powering the 4/20mA output circuit.

11.4.2 System design

The Rate Totalisers 4/20mA output is a passive current sink i.e. not powered, but it is totally isolated from all other Rate Totaliser circuits. It is effectively a 2-wire 4/20mA transmitter requiring a minimum supply of 5V with the output current controlled by the Rate Totaliser's composite rate or total. Subject to complying with intrinsic safety interconnection requirements, the terminals C1 and C2 may be connected to another instrument which supplies power and will accept a 4/20mA transmitter input. The 4/20mA current output may also be transferred to the safe area via a galvanic isolator or Zener barriers. Terminals C2 and C4 are internally linked and may be used for joining a return 4/20mA wire.

Fig 19 shows how a 2-channel Zener barrier may be used to transfer the 4/20mA current output into the safe area, alternatively a galvanic isolator may be used.

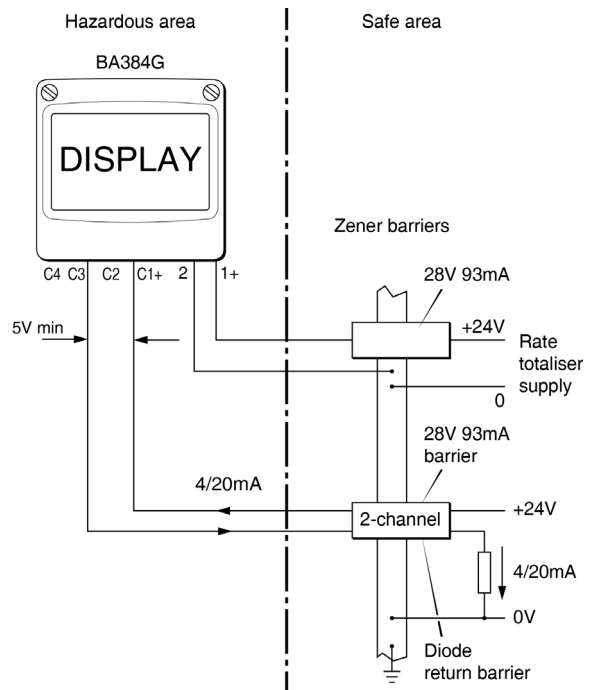

Fig 19 Application of 4/20mA output

11.4.3 Configuration

When a Rate Totaliser is supplied with an optional 4/20mA output the configuration menu is extended as shown in Fig 20. The 4/20mA output sub-menu is accessed via the 4-20 oP function that is located between the PULSE oP and CLR GtEt functions.

The 4/20mA output sub-menu allows the 4/20mA output to be controlled by the composite rate or the composite total display.

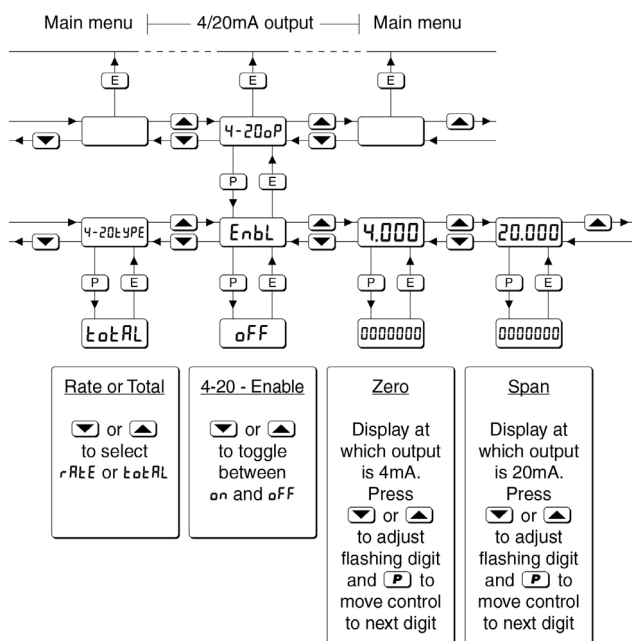

Fig 20 4/20mA output configuration sub-menu

11.4.4 Access 4/20mA output sub-menu: 4-20 oP

Access the Rate Totaliser configuration menu as described in section 6.2. Using the \blacktriangleleft or \blacktriangleright push button scroll through the menu until 4-20 oP is displayed, pressing P will then access the 4/20mA output sub-menu which is shown in Fig 20.

11.4.5 Enable 4/20mA output: EnbL

This function allows the 4/20mA current output to be disabled or enabled without altering the calibration. Using the \blacktriangleleft or \blacktriangleright push button select EnbL in the 4-20 oP sub-menu and press P to reveal the existing setting on or off. The function can be changed by pressing the \blacktriangleleft or \blacktriangleright push button followed by the E button to return to EnbL prompt in the sub-menu.

11.4.6 Select rate or total source: 4-20 tYPE

The 4/20mA output current can represent the Rate Totalisers composite rate or composite total display, which must be defined before any other current output functions are adjusted.

Using the \blacktriangleleft or \blacktriangleright push button select 4-20 tYPE in the 4/20mA output sub-menu and press P to reveal the existing setting tEtRL or rRtE. The function can be changed by pressing the \blacktriangleleft or \blacktriangleright push button followed by the E button to return to the 4-20 tYPE prompt in the sub-menu.

11.4.7 Display which corresponds to 4mA output: 4.000

The composite Rate Totaliser display which corresponds to a 4.000mA output current is defined by this sub-function. Using the \blacktriangleleft or \blacktriangleright push button select 4.000 in the 4/20mA output sub-menu and press P which will reveal the existing display with one digit flashing. The required display can be entered using the \blacktriangleleft or \blacktriangleright push button to adjust the flashing digit and the P button to transfer control to the next digit. When set as required press E to enter the value and return to the 4.000 prompt in the 4/20mA output sub-menu.

11.4.8 Display which corresponds to 20mA output: 20.000

The Rate Totaliser composite display which corresponds to a 20.000mA output current is defined by this function. Using the \blacktriangleleft or \blacktriangleright push button select 20.000 in the 4/20mA output sub-menu and press P which will reveal the existing display with one digit flashing. The required display can be entered using the \blacktriangleleft or \blacktriangleright push button to adjust the flashing digit and the P button to transfer control to the next digit. When set as required press E to enter the value and return to the 20.000 prompt in the 4/20mA output sub-menu.

Notes:

- 1: If the calibration of the source of the 4/20mA output is changed i.e. composite rate or composite total display, the 4/20mA output will automatically be set to give a constant 3.5mA output irrespective of the display. The 4/20mA output must always be reconfigured following reconfiguration of the source display.
- 2: If the Rate Totaliser and the 4/20mA current sink output are powered from separate supplies, the 4/20mA output current will continue to flow when the Rate Totaliser supply fails or is turned off. Powering both from a common supply but via separate Zener barriers or galvanic isolators eliminates this effect.

APPENDIX 1

ATEX Dust Certification

A1.0 ATEX dust certification

In addition to ATEX certification permitting installation in explosive gas atmospheres which is described in the main section of this instruction manual, the BA384G also has ATEX dust certification.

A1.1 Zones, and Maximum Surface Temperature.

The BA384G has been certified Group II Category 1D Ex ia IIIC T80°C Da, Ta = -40° to 60°C. When connected to a suitable system it may be installed in:

- Zone 20 explosive atmosphere in the form of a cloud of combustible dust in air is continuously present, or for long periods or frequently.
- Zone 21 explosive atmosphere in the form of a cloud of combustible dust in air is likely to occur occasionally in normal operation.
- Zone 22 explosive atmosphere in the form of a cloud of combustible dust in air is not likely to occur in normal operation, but if it does occur, will only persist for a short period.

Be used with dust in subdivisions:

- IIIA combustible flyings
- IIIB non-conductive dust
- IIIC conductive dust

Having a Minimum Ignition Temperature of:

Dust cloud 120°C

Dust layer on Rate 155°C
Totaliser up to 5mm thick

Dust layer on Rate Refer to
Totaliser over 5mm thick. EN 60079-14

At an ambient temperature between -40 and +60°C

A1.2 Installation and maintenance

The installation requirement described in this manual for use in a gas potentially explosive atmospheres also apply when the Rate totaliser is installed in a dust potentially explosive atmosphere.

The instrument assembly should only be removed from the enclosure back-box when dust can not enter the instrument enclosure. Before replacing the instrument assembly the sealing gasket should be inspected to ensure that it is undamaged and free from foreign bodies.

It is good practice to prevent dust accumulating on the Rate Totaliser enclosure. If this can not be avoided, care should be taken to ensure that the layer thickness does not exceed 5mm for dusts having a minimum ignition temperature of 155°C.

APPENDIX 2

IECEX certification

A2.0 The IECEX Certification Scheme

IECEX is a global certification scheme for explosion protected products which aims to harmonise international certification standards. For additional information about the IECEX certification scheme and to view the BEKA associate certificates, please visit www.iecex.com

A2.1 IECEX Certificate of Conformity

The BA384G Rate Totaliser and the optional accessories have been issued with an IECEX Certificate of Conformity number IECEX ITS 16.0004X which specifies the following certification codes:

Ex ia IIC T5 Ga
Ta = -40°C to 70°C
Ex ia IIIC T80°C IP66 Da
Ta = -40°C to 60°C

The specified IECEX gas and dust intrinsic safety parameters are identical to the ATEX safety parameters described in the main section and Appendix 1 of this manual.

The IECEX certificate may be downloaded from the BEKA associate of the IECEX websites or requested from the BEKA sales office.

A2.2 Installation

The IECEX and ATEX certificates specify identical safety parameters and installation requirements for both approvals as defined by IEC 60079-14. The ATEX installation requirements specified in the main section and Appendix 1 of this manual may therefore be used for IECEX installations, but the local code of practice should also be consulted.

APPENDIX 3

ETL & cETL certification for installations in USA and Canada.

A3.0 cETL Mark

For installations in the USA and Canada, the BA384G Rate Totaliser has ETL and cETL intrinsic safety and nonincendive approval, Control Number 4008610. Copies of the Authorisation to Mark may be downloaded from the BEKA associates website www.beka.co.uk or requested from the BEKA associates sales office

A3.1 Intrinsic safety approval

The US and Canadian standards used for assessment and certification of the BA337E and BA338E are listed on the cETL Authorisation to Mark.

Installations must comply with BEKA associates Control Drawing CI330-52, which is attached to this appendix.

The ETL safety parameters are the same as the ATEX and IECEx parameters, the systems shown in sections 3 and 4 of this manual may therefore also be used for US and Canadian installations subject to compliance with the local codes of practice.

ETL and cETL intrinsic safety codes

USA & Canada

CL I Div 1 Groups A, B, C, D T5
 CL II Div 1 Groups E, F, G.
 CL III
 $-40^{\circ}\text{C} < \text{Ta} < 70^{\circ}\text{C}$

USA

CL I Zone 0 AEx ia IIC T5 Ga
 Zone 20 AEx ia IIIC T80°C Da
 $-40^{\circ}\text{C} < \text{Ta} < 70^{\circ}\text{C}$

Canada

Ex ia IIC T5 Ga
 Ex ia IIIC T80°C Da
 $-40^{\circ}\text{C} < \text{Ta} < 70^{\circ}\text{C}$

A3.2 Nonincendive approval

The BA384G Rate Totaliser also has ETL nonincendive approval allowing installation in Division 2 hazardous (classified) locations without the need for Zener barriers or galvanic isolators.

Installations must comply with BEKA associates Control Drawing CI330-53, which is attached to this appendix, and with the local codes of practice.

ETL and cETL nonincendive codes US & Canada

CL I Div 2 Groups A, B, C, D T5
 CL II Div 2 Groups F, G
 CL III Div 2
 $-40^{\circ}\text{C} < \text{Ta} < 70^{\circ}\text{C}$

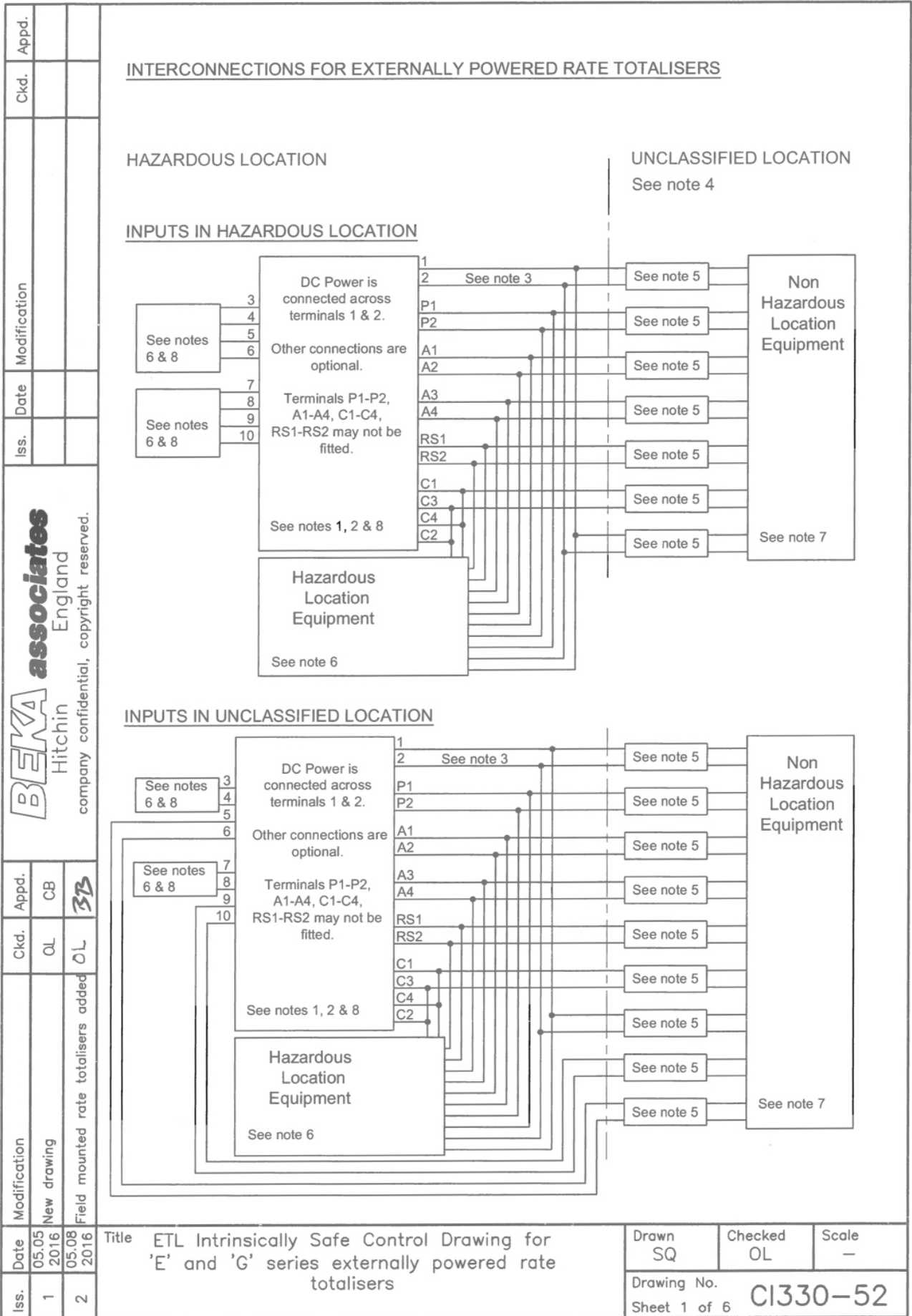

BEKA associates
 Hitchin
 England
 company confidential, copyright reserved.

Iss.	1	Date	05.05 2016	Modification	New drawing	Appd.	CB
Iss.	2	Date	05.08 2016	Modification	Field mounted rate totalisers added	Appd.	OL
Ckd.	OL	Ckd.	OL				

Title ETL Intrinsically Safe Control Drawing for 'E' and 'G' series externally powered rate totalisers

Drawn	Checked	Scale	
SQ	OL	—	
Drawing No.		CI330-52	
Sheet 1 of 6			

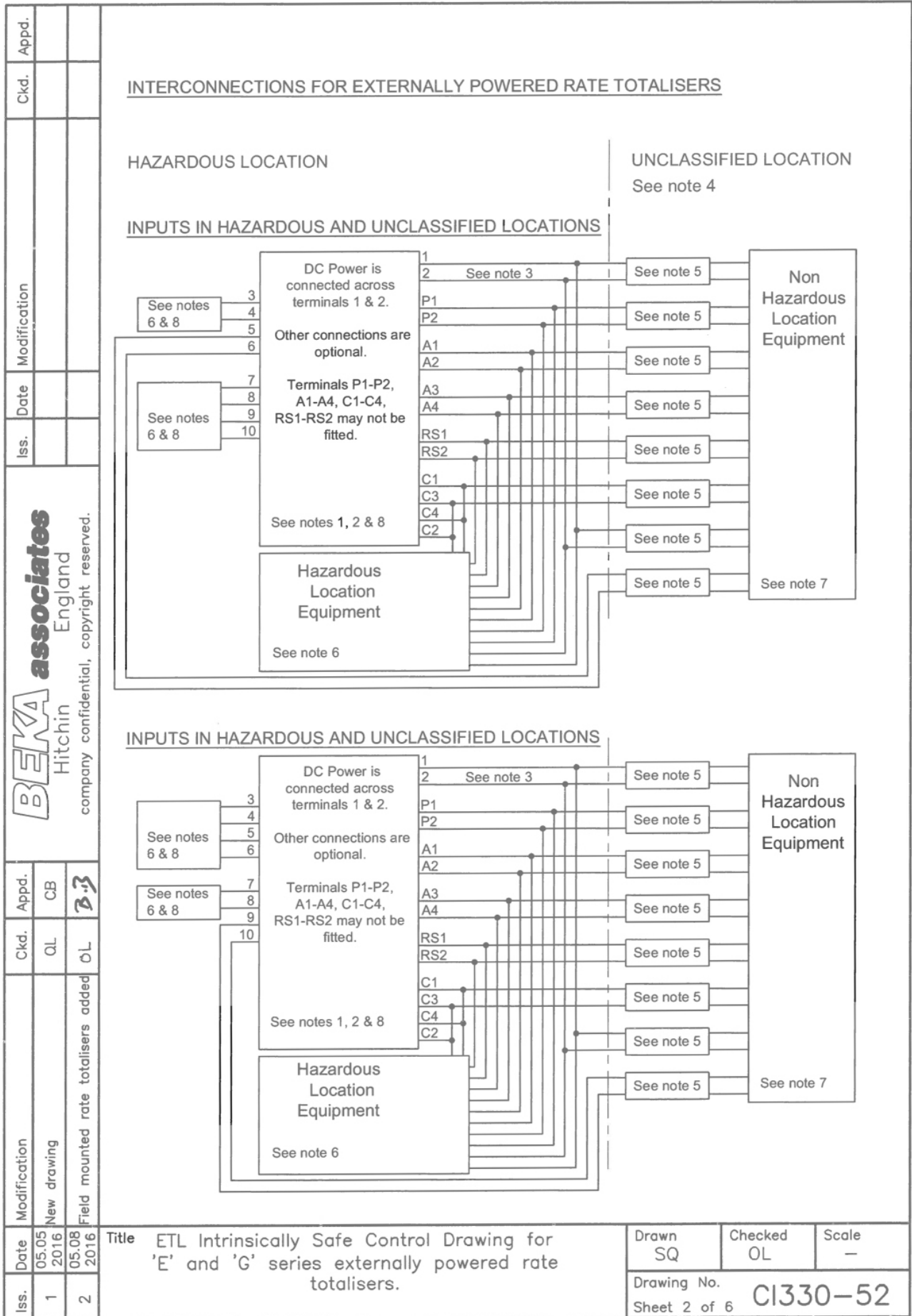

BEKA associates
 Hitchin
 England
 company confidential, copyright reserved.

Iss.	1	Date	05.05 2016	Modification	New drawing	Appd.	CB
Iss.	2	Date	05.08 2016	Modification	Field mounted rate totalisers added	Appd.	DL

Title ETL Intrinsically Safe Control Drawing for 'E' and 'G' series externally powered rate totalisers.

Drawn SQ	Checked OL	Scale —
Drawing No.		CI330-52
Sheet 2 of 6		

Iss.		Date		Modification		Ckd.		Appd.																															
1		05.05 2016		New drawing		OL		CB																															
2		05.08 2016		Field mounted rate totalisers added		OL		BZ																															
																																							
<p>3. Installations shall be in accordance with ANSI/ISA RP 12.06.01 'Installation of Intrinsically Safe Systems for Hazardous (Classified) Locations' and the National Electrical Code ANSI/NFPA 70. Installations in Canada shall be in accordance with the Canadian Electrical Code C22.2.</p> <p>4. The associated protective barriers and galvanic isolators shall be NRTL approved and the manufacturers instructions shall be followed when installing this equipment. For installations in Canada the associated protective barriers and galvanic isolators shall be NRTL or CSA approved and the manufacturers installation drawings shall be followed when installing this equipment.</p> <p>5. One single channel or one two channel associated protective barrier or galvanic isolator with entity parameters complying with the following requirements:</p> <table border="0" style="width: 100%;"> <tr> <td style="width: 15%;">U_o</td> <td style="width: 35%;">equal or less than</td> <td style="width: 50%;">the lowest U_i of the NRTL or CSA approved apparatus installed in the loop.</td> </tr> <tr> <td>I_o</td> <td>equal or less than</td> <td>the lowest I_i of the NRTL or CSA approved apparatus installed in the loop.</td> </tr> <tr> <td>P_o</td> <td>equal or less than</td> <td>the lowest P_i of the NRTL or CSA approved apparatus installed in the loop.</td> </tr> <tr> <td>L_o</td> <td>equal or greater than</td> <td>the sum of the cable inductances and the internal inductances L_i of each NRTL or CSA approved apparatus in the loop.</td> </tr> <tr> <td>C_o</td> <td>equal or greater than</td> <td>the sum of the cable capacitance and the internal capacitance C_i of each NRTL or CSA approved apparatus in the loop.</td> </tr> </table> <p>6. Simple Apparatus as defined in the National Electrical Code ANSI/NFPA 70, or for installations in Canada by the Canadian Electrical Code C22.2 OR:</p> <table border="0" style="width: 100%;"> <tr> <td style="width: 15%;">U_i</td> <td style="width: 35%;">equal or greater than</td> <td style="width: 50%;">the highest U_o of the NRTL or CSA approved apparatus powering the loop.</td> </tr> <tr> <td>I_i</td> <td>equal or greater than</td> <td>the highest I_o of the NRTL or CSA approved apparatus powering the loop.</td> </tr> <tr> <td>P_i</td> <td>equal or greater than</td> <td>the highest P_o of the NRTL or CSA approved apparatus powering the loop.</td> </tr> <tr> <td>L_o</td> <td>of the NRTL or CSA approved apparatus powering the loop equal or greater than</td> <td>the sum of the cable inductances and the internal inductances L_i of each NRTL or CSA approved apparatus in the loop.</td> </tr> <tr> <td>C_o</td> <td>of the NRTL or CSA approved apparatus powering the loop equal or greater than</td> <td>the sum of the cable capacitances and the internal capacitances C_i of each NRTL or CSA approved apparatus in the loop.</td> </tr> </table>										U_o	equal or less than	the lowest U_i of the NRTL or CSA approved apparatus installed in the loop.	I_o	equal or less than	the lowest I_i of the NRTL or CSA approved apparatus installed in the loop.	P_o	equal or less than	the lowest P_i of the NRTL or CSA approved apparatus installed in the loop.	L_o	equal or greater than	the sum of the cable inductances and the internal inductances L_i of each NRTL or CSA approved apparatus in the loop.	C_o	equal or greater than	the sum of the cable capacitance and the internal capacitance C_i of each NRTL or CSA approved apparatus in the loop.	U_i	equal or greater than	the highest U_o of the NRTL or CSA approved apparatus powering the loop.	I_i	equal or greater than	the highest I_o of the NRTL or CSA approved apparatus powering the loop.	P_i	equal or greater than	the highest P_o of the NRTL or CSA approved apparatus powering the loop.	L_o	of the NRTL or CSA approved apparatus powering the loop equal or greater than	the sum of the cable inductances and the internal inductances L_i of each NRTL or CSA approved apparatus in the loop.	C_o	of the NRTL or CSA approved apparatus powering the loop equal or greater than	the sum of the cable capacitances and the internal capacitances C_i of each NRTL or CSA approved apparatus in the loop.
U_o	equal or less than	the lowest U_i of the NRTL or CSA approved apparatus installed in the loop.																																					
I_o	equal or less than	the lowest I_i of the NRTL or CSA approved apparatus installed in the loop.																																					
P_o	equal or less than	the lowest P_i of the NRTL or CSA approved apparatus installed in the loop.																																					
L_o	equal or greater than	the sum of the cable inductances and the internal inductances L_i of each NRTL or CSA approved apparatus in the loop.																																					
C_o	equal or greater than	the sum of the cable capacitance and the internal capacitance C_i of each NRTL or CSA approved apparatus in the loop.																																					
U_i	equal or greater than	the highest U_o of the NRTL or CSA approved apparatus powering the loop.																																					
I_i	equal or greater than	the highest I_o of the NRTL or CSA approved apparatus powering the loop.																																					
P_i	equal or greater than	the highest P_o of the NRTL or CSA approved apparatus powering the loop.																																					
L_o	of the NRTL or CSA approved apparatus powering the loop equal or greater than	the sum of the cable inductances and the internal inductances L_i of each NRTL or CSA approved apparatus in the loop.																																					
C_o	of the NRTL or CSA approved apparatus powering the loop equal or greater than	the sum of the cable capacitances and the internal capacitances C_i of each NRTL or CSA approved apparatus in the loop.																																					
Title						Drawn		Checked		Scale																													
ETL Intrinsically Safe Control Drawing for 'E' and 'G' series externally powered rate totalisers.						SQ		OL		-																													
						Drawing No.						C1330-52																											
						Sheet 4 of 6																																	

Iss.	Date	Modification	Ckd.	Appd.	Iss.	Date	Modification	Ckd.	Appd.	<p>7. The unclassified location equipment shall not use or generate more than 250V rms or 250V dc.</p> <p>8. Safety parameters</p> <p>DC Power terminals 1 & 2</p> <p style="margin-left: 40px;"> $U_i = 28V$ $U_o = 0$ $I_i = 200mA$ $I_o = 0$ $P_i = 0.84W$ $C_i = 2nF$ $L_i = 4\mu H$ </p> <p>Terminals 4,5,6 (input A for models in notes 6 and 7), terminals 8,9,10 (input b for models in note 7).</p> <p style="margin-left: 40px;"> $U_i = 28V$ $U_o = 1.1V$ $I_i = 200mA$ $I_o = 0.5mA$ $P_i = 0.84W$ $P_o = 0.2mW$ $C_i = 2nF$ $L_i = 4\mu H$ </p> <p>Optional pulse output terminals P1 & P2</p> <p style="margin-left: 40px;"> $U_i = 28V$ $U_o = 0$ $I_i = 200mA$ $I_o = 0$ $P_i = 0.84W$ $C_i = 0$ $L_i = 0$ </p> <p>Optional alarm output terminals A1, A2, A3 and A4</p> <p style="margin-left: 40px;"> $U_i = 28V$ $U_o = 1.47V$ $I_i = 200mA$ $I_o = 1\mu A$ $P_i = 0.84W$ $P_o = 2\mu W$ $C_i = 22nF$ $L_i = 4\mu H$ </p> <p>9. When installed purely as intrinsically safe equipment in division 1, division 2, zone 0, zone 1 or zone 2, the ambient temperature range of the BA317E-SS, BA337E-SS, BA367E-SS, BA377E-SS, BA314G, BA334G, BA364G, BA374G and BA384G is: $-40^{\circ}C \leq T_a \leq +70^{\circ}C$.</p>
1	05.05.2016	New drawing	OL		1	05.08.2016	Field mounted rate totalisers added	DL		<p>BEKA associates Hitchin England company confidential, copyright reserved.</p>
2	05.08.2016				2					
Title								<p>ETL Intrinsically Safe Control Drawing for 'E' and 'G' series externally powered rate totalisers.</p>		<p>Drawn SQ</p> <p>Checked OL</p> <p>Scale -</p>
								<p>Drawing No. C1330-52</p> <p>Sheet 5 of 6</p>		

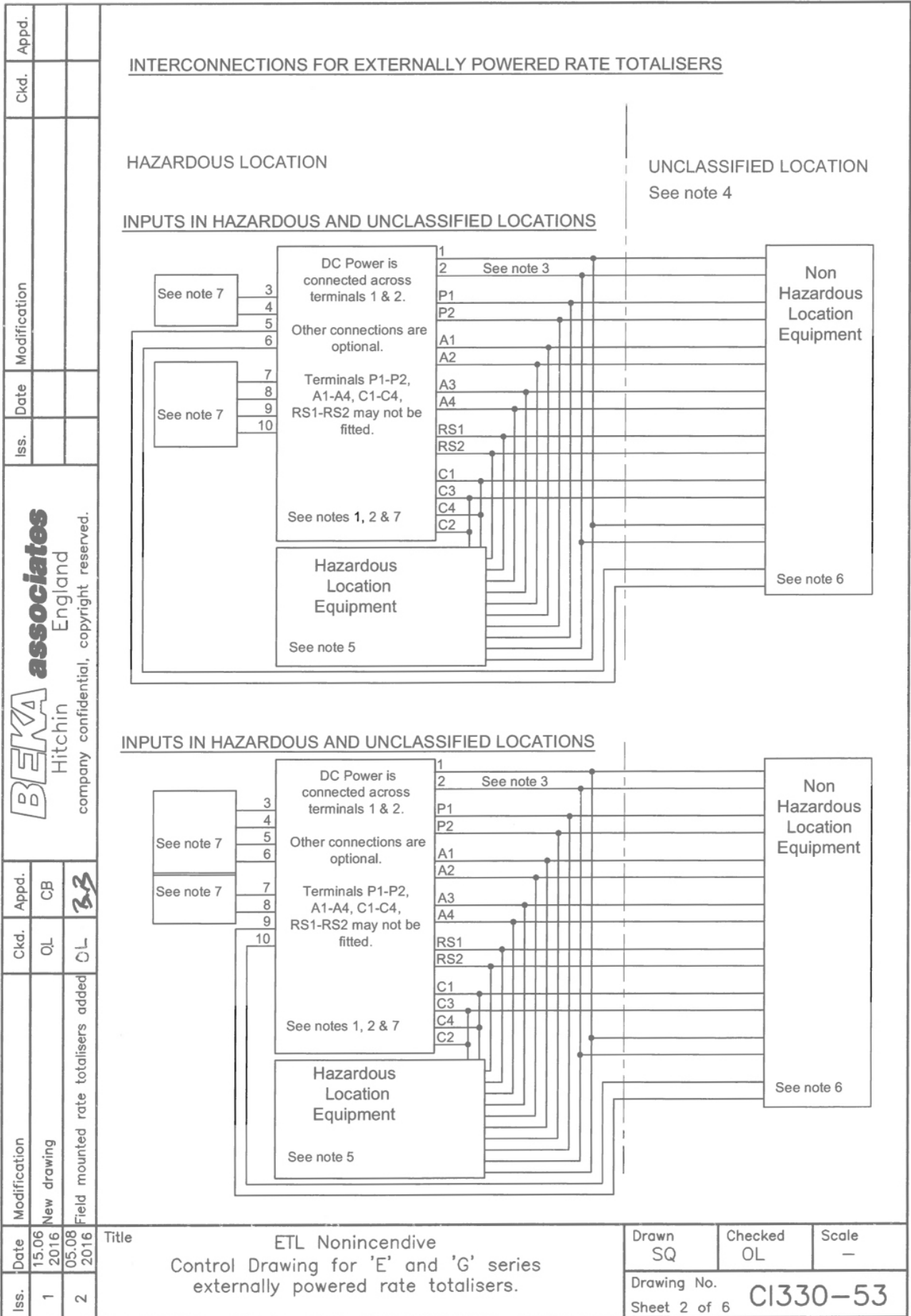

BEKA associates
 Hitchin
 England
 company confidential, copyright reserved.

Iss.	Date	Modification	Ckd.	Appd.
1	15.06.2016	New drawing	OL	CB
2	05.08.2016	Field mounted rate totalisers added	OL	BS

Title

ETL Nonincendive
Control Drawing for 'E' and 'G' series
externally powered rate totalisers.

Drawn SQ	Checked OL	Scale —
Drawing No.		C1330-53
Sheet 2 of 6		

		Iss.	Date	Modification	Ckd.	Appd.			
		1	15.06 2016	New drawing	QL	CB			
		2	05.08 2016	Field mounted rate totalisers added	OL	2.3			
									
<p>2. Terminals 7, 8, 9 and 10 only exist on 2 input instruments.</p> <p>3. Nonincendive field wiring installations shall be in accordance with the National Electrical Code ANSI/NFPA 70. The Nonincendive Field Wiring concept allows interconnection of Nonincendive Field Apparatus with Associated Nonincendive Field Wiring Apparatus using any of the wiring methods permitted for unclassified locations. Installations in Canada shall be in accordance with the Canadian Electrical Code C22.2.</p> <p>4. Classified location equipment shall be NRTL Approved Nonincendive Field Wiring Apparatus or simple apparatus as defined in ANSI/NFPA70. For Canadian installations classified location equipment shall be NRTL or CSA Approved Nonincendive Field Wiring Apparatus.</p> <p>5. Simple Apparatus as defined in the National Electrical Code ANSI/NFPA 70, 3r for installations in Canada by the Canadian Electrical Code C22.2 or as defined in note 2.</p> <p>6. The unclassified location equipment shall not use or generate more than 250V rms or 250V dc.</p>									
		Title ETL Nonincendive Control Drawing for 'E' and 'G' series externally powered rate totalisers.				Drawn SQ	Checked OL	Scale -	
						Drawing No. C1330-53		Sheet 4 of 6	

Iss.	Date	Modification	Iss.	Date	Modification	Ckd.	Appd.
1	15.06 2016	New drawing					
2	05.08 2016	Field mounted rate totalisers added					
			<p>7. Safety parameters</p> <p>DC Power terminals 1 & 2</p> $U_i = 30V$ $I_i = 100mA$ <p>Terminals 4,5,6 (input A for models in notes 5 and 6), terminals 8,9,10 (input b for models in note 6).</p> $U_i = 30V$ $U_o = 1.1V$ $I_o = 0.5mA$ <p>Optional pulse output terminals P1 & P2</p> $U_i = 30V$ $I_i = 100mA$ $U_o = 0$ $I_o = 0$ <p>Optional alarm output terminals A1, A2, A3 and A4</p> $U_i = 30V$ $I_i = 200mA$ $U_o = 1.47V$ $I_o = 1\mu A$ <p>8. The 'AEx ic' in codes refers to instrument push button contacts which are nonincendive.</p> <p>9. When installed purely as non-incendive equipment, the ambient temperature range of the BA317NE, BA337NE, BA367NE, BA377NE, BA314NG, BA334NG, BA364NG, BA374NG, and BA384NG is: $-40^{\circ}C \leq T_a \leq +70^{\circ}C$.</p> <p>Terminals RS1-RS2, (optional reset input)</p> $U_i = 30V$ $U_o = 3.8V$ $I_o = 1mA$ <p>Terminal 3,4,5,6 (for models in notes 5 and 6), terminals 7,8,9,10 (input b with terminals for models in note 6).</p> $U_i = 15V$ $U_o = 10.5V$ $I_o = 9.2mA$ <p>Optional 4-20mA output terminals C1, C2, C3 and C4</p> $U_i = 30V$ $U_o = 0$ $I_o = 0$				
<p>Title</p> <p>ETL Nonincendive Control Drawing for 'E' and 'G' series externally powered rate totalisers.</p>			<p>Drawn SQ</p>		<p>Checked OL</p>		<p>Scale —</p>
<p>Iss.</p>			<p>Drawing No. Sheet 5 of 6</p>		<p>C1330-53</p>		

Iss.		Date		Modification		Ckd.		Appd.					
1		15.06.2016		New drawing									
2		05.08.2016		Field mounted rate totalisers added		OL		B.D					
				<p>10. CAUTION The BA317E, BA318E, BA337E, BA338E, BA367E, BA368E, BA377E, BA378E and the BA388E Externally Powered rate totaliser enclosures may carry the following potential electrostatic warning:</p> <p style="text-align: center;">WARNING Potential electrostatic charging hazard clean only with a damp cloth</p> <p style="text-align: center;">AVERTISSEMENT Risque potentiel de charge électrostatique Nettoyer uniquement avec un chiffon humide</p> <p>Alternatively, the enclosures may be manufactured from a conducting plastic per Article 250 of the National Electrical Code.</p> <p>11. When mounting the BA317E, BA318E, BA337E, BA338E, BA367E, BA368E, BA377E, BA378E, BA388E, BA317E-SS, BA337E-SS, BA367E-SS, BA377E-SS, BA317NE, BA337NE, BA367NE & BA377NE panel mounting Externally Powered Rate Totalisers in an enclosure to maintain Type 4 front panel rating:</p> <p style="text-align: center;">Minimum panel thickness should be 2mm (0.08inches) Steel 3mm (0.12inches) Aluminium</p> <p>Outside panel finish should be smooth, free from particles, inclusions, runs or build-ups around cut-out.</p> <p>Panel cut-out for BA317E, BA337E, BA367E, and BA377E shall be: 90.0 x 43.5mm -0.0 +0.5mm (3.54 x 1.71 inches -0.00 +0.02)</p> <p>Two panel mounting clips are required for BA317E, BA337E, BA367E, and BA377E and each shall be tightened to between: 20 & 22cNm (1.77 to 1.95inLb)</p> <p>Panel cut-out for BA318E, BA338E, BA368E, BA378E, and BA388E shall be: 136.0 x 66.2mm -0.0 +0.5mm (5.35 x 2.60 inches -0.00 +0.02)</p> <p>Four panel mounting clips are required for BA318E, BA338E, BA368E, BA378E, and BA388E and each shall be tightened to between: 20 & 22cNm (1.77 to 1.95inLb)</p> <p>Panel cut-out for BA317E-SS, BA337E-SS, BA367E-SS, BA377E-SS, BA317NE, BA337NE, BA367NE & BA377NE shall be: (92.0mm -0.0 +0.8) x (45.0mm -0.0 +0.6) (3.62 inches -0.00 +0.03) x (1.77 inches - 0.00 +0.02)</p> <p>Four panel mounting clips are required for BA317E-SS, BA337E-SS, BA367E-SS, BA377E-SS, BA317NE, BA337NE, BA367NE & BA377NE and each shall be tightened to at least: 22cNm (1.95inLb)</p>									
Date				Title				Drawn		Checked		Scale	
15.06.2016				ETL Nonincendive Control Drawing for 'E' and 'G' series externally powered rate totalisers.				SQ		OL		-	
05.08.2016								Drawing No.		C1330-53			
								Sheet 6 of 6					

APPENDIX 4

BA384E Rate Totaliser

The BA384E Rate Totaliser is functionally identical to the BA384G Rate Totalisers described in the main sections of this manual, but differs in mechanical construction, certification and factory fitted options.

All BA384E Rate Totalisers are fitted with:

- A green internally powered display backlight

- Dual galvanically isolated alarms

- An isolated 4/20mA current sink output

These are only available as factory fitted options for the BA384G Rate Totaliser.

A4.1 Mechanical construction

The BA384E is housed in a robust GRP IP66 enclosure with a separate terminal compartment. Section A4.5 of this appendix describes the enclosure and installation procedure.

A4.2 Certification

The BA384E has the same ATEX, IECEx and ETL intrinsic safety certification as the BA384G, but the **BA384E does not have ATEX and IECEx dust certification.**

The safety parameters and certification numbers specified in this manual for the BA384G Rate Totalisers also apply to the BA384E Rate Totaliser. Therefore all of the systems described for the BA384G in the main section of this manual may also be used for the BA384E.

A4.3 Location

The BA384E Rate Totaliser is housed in a robust IP66 glass reinforced polyester (GRP) enclosure incorporating an armoured glass window and stainless steel fittings. It is suitable for exterior mounting in most industrial installations, including off-shore and waste water treatment sites. The Rate Totaliser should be positioned where the display is not in continuous direct sunlight.

The field terminals and the two mounting holes are located in a separate compartment with a sealed cover allowing the instrument to be installed without exposing the display assembly.

The enclosure is fitted with a bonding plate to ensure electrical continuity between the three conduit / cable entries.

A4.4 BA384E Accessories

A4.4.1 Units measurement & instrument identification.

The BA384E is fitted with a blank escutcheon around the liquid crystal display. This can be supplied printed with any units of measurement and tag information specified at the time of ordering. Alternatively, the information may be added on-site via an embossed strip, dry transfer or a permanent marker.

To gain access to the escutcheon remove the terminal cover by unscrewing the two 'A' screws which will reveal two concealed 'D' screws. Remove the push buttons by unscrewing the two 'C' screws and un-plug the five way connector. Finally, unscrew all four 'D' screws and carefully lift off the front of the instrument. The location of all the screws is shown in Fig A4.1.

Add the required legend to the display escutcheon, or stick a new pre-printed self-adhesive escutcheon, which is available from BEKA associates, on top of the existing escutcheon. Do not remove the original escutcheon.

The BA384E can also be supplied with a blank or custom laser engraved stainless steel plate secured by two screws to the front of the instrument enclosure. This plate can typically accommodate:

- 1 row of 9 alphanumeric characters 10mm high

- or 1 row of 11 alphanumeric characters 7mm high

- or 2 rows of 18 alphanumeric characters 5mm high.

A4.4.2 Pipe mounting kits

The BA384E Rate Totaliser is surface mounting, but may be pipe mounted using the BA392D or the BA393 pipe mounting kit.

A4.5 Installation Procedure

Fig A4.1 illustrates the instrument installation procedure.

- a. Remove the instrument terminal cover by unscrewing the two captive 'A' screws.
 - b. Mount the instrument on a flat surface and secure with screws or bolts through the two 'B' holes. Alternatively secure to a vertical or horizontal pipe using a BA392D or BA393 pipe mounting kit.
 - c. Remove the temporary hole plug and install an appropriate IP rated cable gland or conduit fitting. If more than one entry is required, one or both of the IP66 stopping plugs may be replaced with an appropriate IP rated cable gland or conduit fitting.
 - d. Connect the field wiring to the terminals as shown in Fig A4.2.
- 6 Replace the instrument terminal cover and evenly tighten the two 'A' screws.

If the BA384E is not bolted to an earthed post or structure, the earth terminal should be connected to the plant potential equalising conductor.

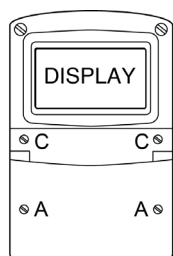

Step A

Remove the terminal cover by unscrewing the two 'A' screws

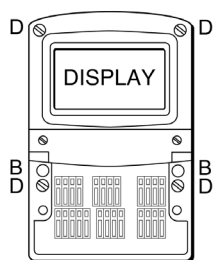

Step B

Secure the instrument to a flat surface with M6 screws through the two 'B' holes. Alternatively use a pipe mounting kit.

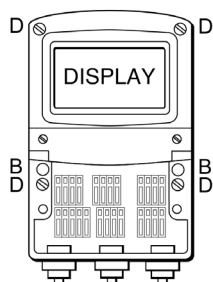

Step C and D

Remove the temporary hole plug and install an appropriate IP rated cable gland or conduit fitting and terminate field wiring. Finally replace the terminal cover and tighten the two 'A' screws.

Fig A4.1 BA384E installation procedure

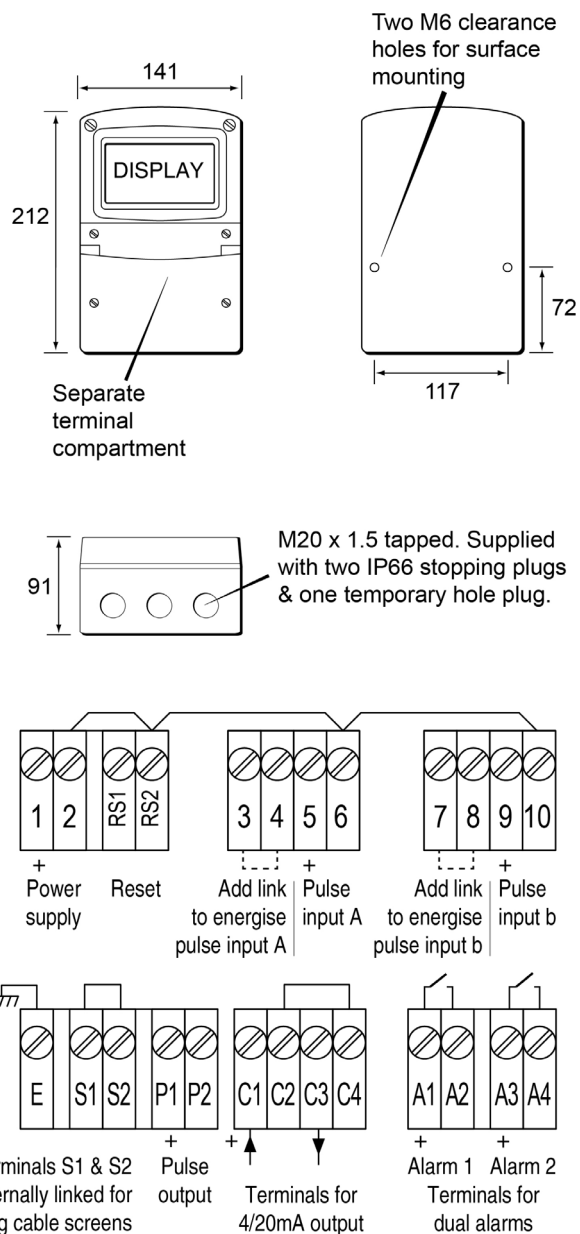

Fig A4.2 Dimensions and terminal connections

A4.6 EMC

The BA384E complies with the requirements of the European EMC Directive 2014/30/EU. For specified immunity all wiring should be in screened twisted pairs, with the screens earthed in the safe area.