

BA377E-SS
Rugged one input
intrinsically safe
Timer or Clock

Issue 6

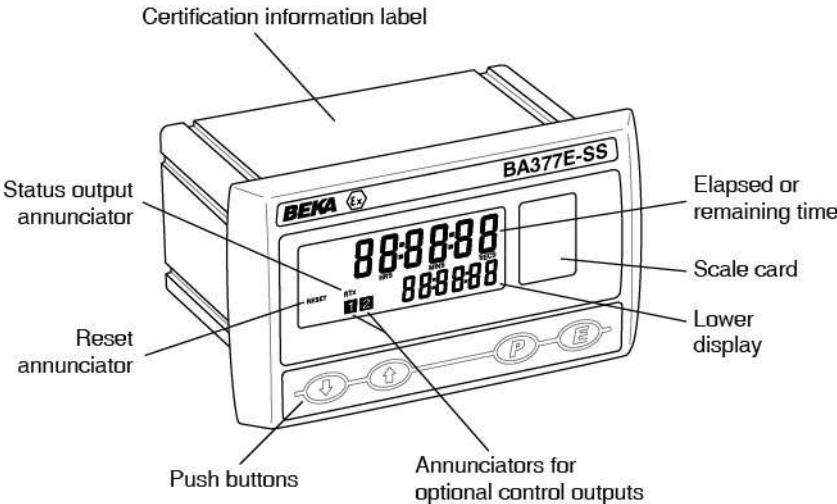

CONTENTS

1. DESCRIPTION

2. INTRINSIC SAFETY CERTIFICATION

- 2.1 ATEX gas certification
- 2.2 Zones, gas groups and T rating
- 2.3 Special conditions for safe use
- 2.4 Power supply
- 2.5 Input terminals
 - 2.5.1 Sensors that do not require energising.
 - 2.5.2 Sensors that require energising
- 2.6 Remote reset terminals
- 2.7 Control outputs - optional
- 2.8 Certification label information

3. SYSTEM DESIGN FOR HAZARDOUS AREAS

- 3.1 Use with Zener barriers
 - 3.1.1 Power supply
 - 3.1.2 Sensor inputs
 - 3.1.3 Switch contact input
 - 3.1.4 Open collector input
 - 3.1.5 2-wire proximity detector input
 - 3.1.6 Magnetic pick-off input
 - 3.1.7 Voltage input
 - 3.1.8 Remote reset
 - 3.1.9 Control outputs - optional
- 3.2 Use with Galvanic Isolators
 - 3.2.1 Power supply
 - 3.2.2 Sensor inputs
 - 3.2.3 Switch contact input
 - 3.2.4 Open collector input
 - 3.2.5 2-wire proximity detector input
 - 3.2.6 Magnetic pick-off input
 - 3.2.7 Voltage input
 - 3.2.8 Remote reset
 - 3.2.9 Control outputs - optional
- 3.3 Use in an Ex e or Ex p panel enclosure in Zone 1 or Zone 2.
 - 3.3.1 Installation in an Ex e panel enclosure within Zone 1 or Zone 2.
 - 3.3.2 Installation in an Ex p panel enclosure within Zone 1 or Zone 2.

4. INSTALLATION

- 4.1 Location
- 4.2 Installation procedure
- 4.3 EMC
- 4.4 Timer or clock earthing
- 4.5 Scale card

5. ACCESSORIES

- 5.1 Display backlight
- 5.2 Control outputs
- 5.3 Scale card
- 5.4 Tag information
- 5.5 BA495 rear sealing kit

6. OPERATION AS A TIMER

- 6.1 Initialisation
- 6.2 Controls when configured as a Timer
- 6.3 Displays when configured as a Timer
- 6.4 Timer structure
- 6.5 Configuration as a Timer
 - 6.5.1 Accessing configuration functions
 - 6.5.2 Summary of Timer configuration functions.
 - 6.5.3 Instrument function: $F_{un}E_{t, on}$
 - 6.5.4 Input: INP_{ut}
 - 6.5.5 Input type: INP_{tYPE}
 - 6.5.6 debounce: $dEb_{oun}E$
 - 6.5.7 Lower display: $d_{i}SP-2$
 - 6.5.8 Starting & stopping the Timer: $StAr-5t_{oP}$
 - 6.5.9 Units of display: $u_{n}t_{5}$
 - 6.5.10 Set time: SEt_{t}
 - 6.5.11 Repeat timing cycle: $E_{Y}E_{5}$
 - 6.5.12 Cycle function enable: $E_{nb}L$
 - 6.5.13 Cycle count: $E_{Y}E_{L}E_{nt}$
 - 6.5.14 Restart delay: $r_{5t}dELR$
 - 6.5.15 Adjusting the set time SEt_{t} and restart delay $r_{5t}dELR$ from the display mode: $R_{E}SEt_{t}$
 - 6.5.16 Direction of count: $uP_{or}dn$
 - 6.5.17 Power fail: P_{FR}_{L}
 - 6.5.18 Local reset: $L_{o}C_{r}E_{t}$
 - 6.5.19 Local total reset: $r_{E}SEt_{t}.E_{nb}L$
 - 6.5.20 Local grand total reset: $E_{Lr}G_{t}o_{t}$
 - 6.5.21 Control output 1 (Optional): oP_{I}
 - 6.5.22 Control output 1 enable: $E_{nb}L$
 - 6.5.23 Control output on at: $oP_{I}o_{n}$
 - 6.5.24 Control output off at: $oP_{I}o_{FF}$
 - 6.5.25 Output on delay time: $oP_{I}dELR$
 - 6.5.26 Control output 2 (Optional): oP_{2}
 - 6.5.27 Reset grand total from within the configuration menu: $E_{Lr}G_{t}o_{t}$
 - 6.5.28 Security code: $E_{o}dE$
 - 6.5.29 Reset configuration to Timer factory defaults: $r_{5E}t_{dEF}$

7. TIMER APPLICATION EXAMPLES

- 7.1 Measuring the time that a contact is closed
- 7.2 Controlling an IS solenoid valve

8 MAINTENANCE when configured as a Timer

- 8.1 Fault finding during commissioning
- 8.2 Fault finding after commissioning
- 8.3 Servicing
- 8.4 Routine maintenance
- 8.5 Guarantee
- 8.6 Customer comments

9. OPERATION AS A CLOCK

- 9.1 Initialisation and loss of power
- 9.2 Controls when configured as a clock
- 9.3 Displays when configured as a clock
- 9.4 Configuration as a clock
 - 9.4.1 Accessing configuration functions
 - 9.4.2 Summary of Clock configuration functions.
 - 9.4.3 Instrument function: *Funct, on*
 - 9.4.4 Display format: *di SP LRY*
 - 9.4.5 Set Clock display time: *SEt*
 - 9.4.6 Enter synchronising time: *SYnE t*
 - 9.4.7 Control output 1 (Optional): *oP 1*
 - 9.4.8 Enable Control output 1: *EnbL*
 - 9.4.9 On and off times:
 - oP 1: on 1; oP 1: oFF 1*
 - oP 1: on 2; oP 1: oFF 2*
 - 9.4.10 Control output 2 (Optional): *oP 2*
 - 9.4.11 Enable control output 2: *EnbL*
 - 9.4.12 On and off times:
 - oP 2: on 1; oP 2: oFF 1*
 - oP 2: on 2; oP 2: oFF 2*
 - 9.4.13 Access *on & off* times from display mode: *RLSP*
 - 9.4.14 Security code: *EdE*
 - 9.4.15 Reset configuration to Clock factory defaults: *rSEt dEF*

10. CLOCK CONFIGURATION EXAMPLE

- 10.1 Configuration procedure

11. MAINTENANCE when configured as a Clock

- 11.1 Fault finding during commissioning
- 11.2 Fault finding after commissioning
- 11.3 Servicing
- 11.4 Routine maintenance
- 11.5 Guarantee
- 11.6 Customer comments

Appendix 1 ATEX Dust certification

Appendix 2 IECEx certification

Appendix 3 ETL and cETL certification

1. DESCRIPTION

The BA377E-SS is a rugged intrinsically safe, panel mounting instrument with a single input that can be configured as a Timer or as a Clock. As a Timer the BA377E-SS is able to measure and display the elapsed time between external events, or control external events via two optional factory fitted control outputs.

When configured as a Clock, the instrument can display time in a variety of formats and the two optional control outputs may be configured to switch loads *on* and *off* at pre-set times.

This instruction manual is divided into sections.

Common features

2. Intrinsic safety certification
3. System design for hazardous areas
4. Installations
5. Accessories

Timer

6. Operation as a timer
7. Configuration example
8. Maintenance

Clock

9. Operation as a clock
10. Configuration example
11. Maintenance

The BA377E-SS has been certified intrinsically safe for use in gas and dust hazardous areas by Notified Body Intertek Testing and Certification Ltd and complies with the European ATEX Directive 2014/34/EU. It has a rugged stainless steel enclosure and an impact resistant glass window. In addition to normal intrinsically safe applications, the certification allows it to be installed in an Ex e, Ex n, Ex p or Ex t panel enclosure without invalidating the panel enclosure's certification.

The common features sections of this instruction manual describe ATEX certification for use in gas atmospheres. Dust certification is described in Appendix 1.

For international applications the BA377E-SS has IECEx certification which is described in Appendix 2.

This instruction manual supplements the abbreviated instruction sheet supplied with each instrument.

2. INTRINSIC SAFETY CERTIFICATION

The BA377E-SS has IECEx and ATEX gas certification. This section of the instruction manual describes ATEX gas certification. IECEx and other approvals are each described in separate appendixes to this manual. The intrinsic safety of the instrument is unaffected by whether it is configured as a Timer or as a Clock.

2.1 ATEX gas certification

Notified Body Intertek Testing and Certification Ltd have issued the BA377E-SS with an EU-Type Examination Certificate number ITS16ATEX28408X. This confirms compliance with harmonised European standards and it has been used to confirm compliance with the European ATEX Directive for Group II, Category 1G equipment. The Timer or Clock carries the European Community mark and subject to local codes of practice may be installed in any of the European Economic Area (EEA) member countries. ATEX certificates are also acceptable for installations in Switzerland.

This section of the instruction manual describes ATEX installations in explosive gas atmospheres complying with EN60079-14 *Electrical Installation Design, Selection and Erection*. When designing systems for installation outside the UK the local Code of Practice should be consulted.

2.2 Zones, gas groups and T rating

The BA377E-SS Timer or Clock has been certified Ex ia IIC T5 Ga. When connected to a suitable system it may be installed in:

Zone 0	explosive gas air mixture continuously present.
Zone 1	explosive gas air mixture likely to occur in normal operation.
Zone 2	explosive gas air mixture not likely to occur, and if it does will only exist for a short time.

In gases that may be used with equipment having a temperature classification of:

Group A	propane
Group B	ethylene
Group C	hydrogen

Having a temperature classification of:

T1	450°C
T2	300°C
T3	200°C
T4	135°C
T5	100°C

At ambient temperatures between:

-40 to +60°C When installed as an Ex i intrinsically safe instrument in an Ex e, Ex n, Ex p or Ex t enclosure.

-40 to +70°C When used as an Ex i intrinsically safe instrument **not** in an Ex e, Ex n, Ex p or Ex t enclosure.

2.3 Special conditions for safe use

The ATEX intrinsic safety certificate number has an 'X' suffix indicating that for some applications special conditions apply for safe use.

When installed in an Ex e, Ex n, Ex p or Ex t panel enclosure all connections to the BA377E-SS must be made by appropriately rated Zener barriers or galvanic isolators.

This means that when installed in an Ex e, Ex n, Ex p or Ex t panel enclosure the BA377E-SS remains an intrinsically safe instrument and must comply with the installation requirements shown in this manual.

The certificate also states:

The front of the stainless steel enclosure complies with the requirements for Ex e, Ex n Ex p & Ex t type of protection.

Therefore when correctly installed the BA377E-SS Timer or Clock will not invalidate the Ex e, Ex n, Ex p or Ex t panel enclosure certification in which it is mounted.

Note: At temperatures below -20°C the instruments will continue to function, but the display response will become slower and the contrast will be reduced.

2.4 Power supply

When installed in a hazardous area the BA377E-SS must be powered via a certified Zener barrier or galvanic isolator from a dc supply located in the safe area, or from certified associated apparatus with an intrinsically safe output.

The input safety parameters of the BA377E-SS power supply terminals 1 and 2 are:

$$\begin{aligned} U_i &= 28V \text{ dc} \\ I_i &= 200\text{mA dc} \\ P_i &= 0.84W \end{aligned}$$

Any certified Zener barrier or galvanic isolator with output safety parameters equal to or less than these limits may be used to power the BA377E-SS.

The maximum equivalent capacitance and inductance between terminals 1 and 2 is:

$$\begin{aligned} C_i &= 2\text{nF} \\ L_i &= 4\mu\text{H} \end{aligned}$$

To determine the maximum permissible power supply cable parameters the above figures, which are small and may be ignored for many applications, should be subtracted from the maximum permitted parameters, C_o and L_o , specified for the Zener barrier or galvanic isolator powering the BA377E-SS.

2.5 Input terminals

When configured as a Timer the BA377E-SS is controlled via a single input that may be configured for use with different types of sensor. The input is a separate intrinsically safe circuit, although the negative side is internally connected to the negative side of the power supply and the reset terminal RS2. See Fig 15.

Some types of sensor that may be connected to the BA377E-SS input, such as a switch contact or a 2-wire proximity detector, require energising to determine their state. For sensors requiring energising fitting an external link between terminals 3 & 4 connects an internal 7V, 6mA supply to the input. Energising is not required when the BA377E-SS input is connected to a voltage input source.

Fitting an energising link changes the output safety parameters of the BA377E-SS input as shown in the following table which also shows the types of sensor requiring energising (link fitting).

Output safety parameters of input terminals 5 & 6.

Type of input	Link*	U_o	I_o	P_o
Switch contact	Yes	10.5V	8.2mA	25mW
Proximity detector	Yes	10.5V	8.2mA	25mW
Open collector	Yes	10.5V	8.2mA	25mW
Magnetic pick-off	No	1V	11µA	3µW
Voltage input (low)	No	1V	11µA	3µW
Voltage input (high)	No	1V	11µA	3µW

*Link terminals 3 and 4

2.5.1 Sensors that do not require energising

Sensors with a voltage output do not require energising, therefore terminals 3 & 4 should not be linked. When not energised i.e. without a link the BA377E-SS input complies with the requirements for *simple apparatus*. For intrinsic safety purposes, sources of energy with output parameters less than 1.5V; 100mA and 25mW are considered to be *simple apparatus* (Clause 5.7 of EN60079-11), which allows them not to be considered or documented when assessing the safety of an intrinsically safe system, thus simplifying loop assessment.

This allows almost any voltage output sensor to be directly connected to the BA377E-SS input in a hazardous area providing that:

- a. The sensor is a certified intrinsically safe device having output parameters equal to or less than:

$$\begin{array}{lcl} U_o & \leq & 28V \text{ dc} \\ I_o & \leq & 200mA \text{ dc} \\ P_o & \leq & 0.84W \end{array}$$

or complies with requirements for *simple apparatus*.

- b. The sensor and associated wiring can withstand a 500V rms insulation test to earth.
c. The sensor is located in the same hazardous area as the BA377E-SS.

The BA377E-SS EC-Type Examination Certificate specifies that the equivalent capacitance and inductance of the BA377E-SS sensor input is:

$$\begin{array}{lcl} C_i & = & 2nF \\ L_i & = & 4\mu H \end{array}$$

To determine the maximum permissible cable parameters these figures should be subtracted from the maximum permitted output parameters L_o and C_o specified by the certificate for the sensor connected to the BA377E-SS input terminals. The BA377E-SS input parameters are small and therefore unlikely to make a significant difference to the allowable cable parameters.

2.5.2 Sensors that require energising

Switch contacts, proximity detectors and open collector sensors require energising which is achieved by linking two BA377E-SS terminals together as described in section 2.5. When energised, the output parameters of the BA377E-SS input are:

$$\begin{array}{lcl} U_o & = & 10.5V \text{ dc} \\ I_o & = & 8.2mA \text{ dc} \\ P_o & = & 25mW \end{array}$$

These parameters do not comply with the requirements for *simple apparatus* and should be considered when assessing the safety of the sensor connected to a BA377E-SS input.

Any certified intrinsically safe sensor may be connected to the BA377E-SS energised input providing that the sensor's input safety parameters are equal to, or greater than, the output safety parameters of the BA377E-SS input shown above. This is not restrictive and most intrinsically safe sensors will comply. A sensor complying with the requirements for *simple apparatus*, such as a mechanically operated switch contact, may also be connected.

This allows most mechanically operated switches, open collector transistors and certified intrinsically safe NAMUR proximity detectors to be directly connected to the BA377E-SS energised input. The sensor and wiring should be able to withstand a 500V rms insulation test to earth and the sensor should be located in the same hazardous area as the BA377E-SS.

The BA377E-SS EC-Type Examination Certificate specifies that the maximum capacitance and inductance that may be safely connected to the energised input (link connected) is:

$$\begin{array}{lcl} C_o & = & 2.4\mu F \\ L_o & = & 200mH \end{array}$$

Again this is not restrictive as the combined capacitance and inductance of most sensors and connecting cable will be less than this.

2.6 Remote reset terminals

Connecting the external reset terminals RS1 and RS2 together will reset the BA377E-SS when configured as a Timer and synchronise the displayed time when configured as a Clock. The two reset terminals have the following input and output safety parameters:

U_o	=	3.8V dc
I_o	=	1.6mA dc
P_o	=	2.0mW
U_i	=	28V dc
I_i	=	200mA dc
P_i	=	0.84W

The equivalent capacitance and inductance between them is:



C_i	=	0nF
L_i	=	0 μ H

The maximum cable capacitance and inductance that may be safely connected between the reset terminals RS1 and RS2 is:

C_o	=	40 μ F
L_o	=	1H

The reset terminals may be directly connected to any mechanically operated switch located within the same hazardous area as the BA377E-SS. The switch and associated wiring should be able to withstand a 500V insulation test to earth.

If the reset switch is required in the safe area a Zener barrier or intrinsically safe relay is required to transfer the contact closure into the hazardous area. A diode return barrier is not suitable for this application. Almost any intrinsically safe relay with certification permitting the contacts to be connected to equipment in the hazardous area may be used.

When used as a Timer the BA377E-SS may also be reset from the display mode by operating the  and  push buttons simultaneously for more than two seconds. See 6.5.19

2.7 Control outputs - optional

Each of the two factory fitted optional control outputs is a separate galvanically isolated intrinsically safe circuit with output safety parameters complying with the requirements for *simple apparatus*. This allows the control output terminals A1 & A2 and A3 & A4 to be connected to almost any intrinsically safe circuit protected by a Zener barrier or galvanic isolator providing the output safety parameters of the circuit do not exceed:

U_o	\leq	28V dc
I_o	\leq	200mA dc
P_o	\leq	0.84W

The maximum equivalent capacitance and inductance between each set of control output terminals is:

C_i	=	22nF
L_i	=	8 μ H

To determine the maximum permissible cable capacitance C_i should be subtracted from the maximum permitted external capacitance C_o specified by the certificate for the intrinsically safe interface powering the circuit being switched by the control output. See fig 4.

2.8 Certification label information

The BA377E-SS product certification label is fitted in a recess on the top outer surface of the enclosure. It shows the ATEX and IECEx certification information plus BEKA associates name and location and the instrument serial number. Certification information from other authorities may also be included.



BA377E-SS Certification information label

3. SYSTEM DESIGN FOR HAZARDOUS AREAS

3.1 Use with Zener barriers

Zener barriers are the least expensive intrinsically safe interface between a safe and hazardous area. However, they require a high integrity earth connection that may be expensive to install and they do not provide isolation. When a high integrity earth connection is not already available, it may be less expensive and complicated to use galvanic isolators for the installation of a single BA377E-SS.

Terminals 2, 6 and RS2 of the BA377E-SS are internally connected together as shown in Fig 15. If any of these terminals are earthed, as shown in Figs 1 & 2, the other common terminals should only be connected to the same earth, i.e. the barrier busbar, or to circuits that have at least 500V insulation to earth.

Any Zener barrier certified for the gas group and Zone in which the BA377E-SS is installed may be used, providing the output parameters do not exceed the input parameters of the BA377E-SS terminals to which it is connected. Only one polarity of Zener barrier i.e. positive or negative may be used in each system.

Fig 1 illustrates the basic circuit that is used for all BA377E-SS Timer installations protected by Zener barriers. BA377E-SS Clock installations are the same, except that the input terminals 5 & 6 are not used. For simplicity the optional control outputs are described separately in section 3.1.9 of this manual.

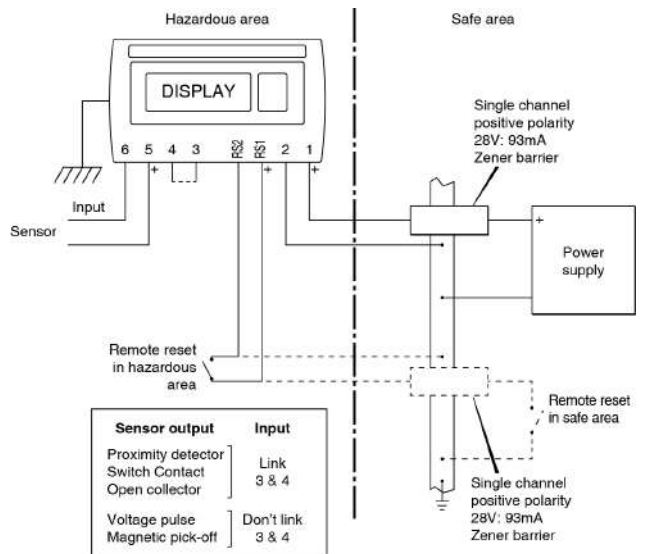

Fig 1 BA377E-SS Timer used with Zener barriers

Alternatively the sensor may be located in the safe area. Fig 2 shows how an additional Zener barrier is used to transfer signals to the Timer in the hazardous area.

When more than one Zener barrier is used in a system all must have the same polarity. i.e. all positive or all negative barriers. When designing a Timer system it is important to remember that terminals 2, 6 and RS2 of the BA377E-SS are connected together within the instrument. Similarly, terminals 2 and RS2 are internally connected together when the BA377E-SS is configured as a Clock. See Fig 20.

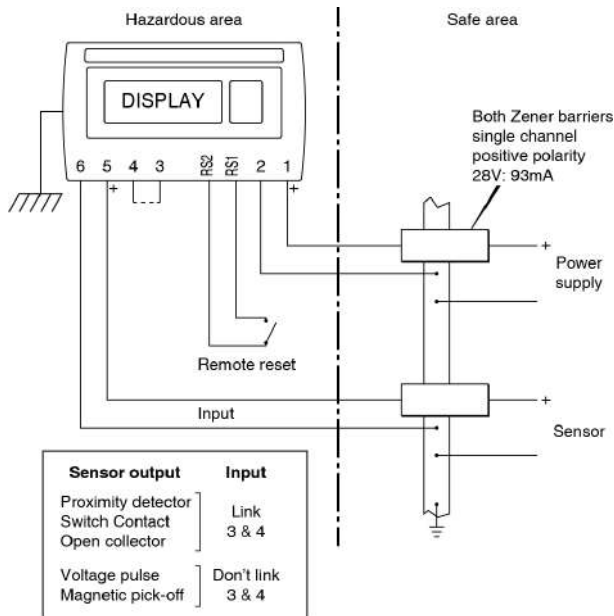

Fig 2 BA377E-SS Timer used with Zener barriers and input sensor in the safe area.

3.1.1 Power supply

The BA377E-SS requires a minimum of 10V between terminal 1 & 2 and consumes:

10mA	without optional backlight
plus 22mA	for optional backlight
plus 6mA	when terminals 3 & 4 are linked

Any Zener barrier certified for the gas group and Zone in which the BA377E-SS is installed may be used to power the instrument, providing the output safety parameters of the barrier are equal to or less than the input safety parameters of terminals 1 & 2.

Although this allows a wide variety of barriers to be used, a positive polarity 28V; 93mA; 300Ω Zener barrier, which has an end-to-end resistance of about 340Ω, is an industry standard device which is frequently used. With this barrier the supply voltage in the safe area must be between the minimum value shown below and the maximum working voltage of the Zener barrier which, depending upon manufacturer, will be approximately 26V.

13.5V min	without optional backlight
20.9V min	with optional backlight
plus 2.1V	when terminals 3 & 4 are linked

3.1.2 Sensor input

When configured as a Timer the sensor input may be connected to a wide variety of hazardous area devices as shown in Fig 1, or to safe area sensor as shown in Fig 2. The input must be maintained not momentary. The BA377E-SS input is not used when the instrument is configured as a Clock.

No Zener barrier is required in series with the input if the intrinsically safe sensor is located within the same hazardous area as the BA377E-SS. The following table shows the instrument's input switching thresholds when configured to operate with various sensors. For reliable operation the BA377E-SS input must fall below the lower threshold and rise above the upper threshold.

Sensor	Switching thresholds	
	Lower	Upper
Low voltage range	1.0V	3.0V
High voltage range	3.0V	10.0V
Proximity detector	1.2mA	2.1mA
Switch	100Ω	1000Ω
Open collector	2kΩ	10kΩ

Switch contacts, proximity detectors and open collector sensors require energising which is achieved by linking terminals 3 and 4 together as described in section 2.5.

3.1.3 Switch contact input

Any mechanically activated switch contact may be directly connected to input terminals 5 & 6 providing the switch is located in the same hazardous area as the BA377E-SS, and the switch and associated wiring can withstand a 500V rms insulation test to earth. Most industrial push buttons and magnetically activated reed relays comply with these requirements. The BA377E-SS contains a configurable debounce circuit to prevent false triggering of the instrument. Three levels of debounce protection are available. See section 6.5.6.

3.1.4 Open collector input

Any sensor with an open collector output located in the same hazardous area as the BA377E-SS, such as a mechanically activated opto-isolator may be directly connected to input terminals 5 & 6. The sensor and the associated wiring must be able to withstand a 500V rms insulation test to earth. The BA377E-SS contains a configurable debounce circuit to prevent false triggering. Three levels of debounce protection are available. See section 6.5.6.

3.1.5 2-wire proximity detector input

Most intrinsically safe NAMUR 2-wire proximity detectors may be connected to the BA377E-SS sensor input, providing the input safety parameters of the proximity detector are equal to or greater than the output safety parameters of a BA377E-SS input. i.e.

U_i	\geq	10.5V dc
I_i	\geq	8.2mA dc
P_i	\geq	25mW

and the minimum operating voltage of the proximity detector is less than 7.5V. The proximity detector must be located in the same hazardous area as the BA377E-SS.

The BA377E-SS contains a configurable debounce circuit to prevent false triggering of the instrument. Three levels of debounce protection are available. See section 6.5.6.

3.1.6 Magnetic pick-off input

U_{OL} in the input configuration menu is a low level voltage input intended for use with an intrinsically safe magnetic pick-off sensor which is not suitable for controlling a BA377E-SS.

3.1.7 Voltage input

Two voltage input ranges are selectable in the BA377E-SS Timer configuration menu, $U_{OL} \leq 5 L$ and $U_{OL} \leq 5 H$. When configured for either of the voltage ranges and terminals 3 and 4 are not linked, the input terminals 5 and 6 comply with the requirements for *simple apparatus*. This allows the input to be connected to any certified intrinsically safe voltage source located within the same hazardous area as the BA377E-SS having output parameters equal to or less than:

U_o	\leq	28V dc
I_o	\leq	200mA dc
P_o	\leq	0.84W

The BA377E-SS Timer may therefore be directly connected to and controlled by most certified intrinsically safe high level voltage signals.



The maximum permitted cable parameters will be defined by the intrinsic safety certification of the voltage source less the BA377E-SS input parameters which are small and can often be ignored.

The BA377E-SS contains a configurable debounce circuit to prevent false triggering of the instrument. Three levels of debounce protection are available. See section 6.5.6.

3.1.8 Remote reset

Connecting the external reset terminals RS1 and RS2 together will reset the BA377E-SS when configured as a Timer and synchronise the displayed time when configured as a Clock. Remote resetting may be accomplished by any mechanically operated switch located in the same hazardous area as the instrument providing the switch and the associated wiring can withstand a 500V rms insulation test to earth. No Zener barrier is required.

A BA377E-SS may also be remotely reset from the safe area. Any switch may be used but a Zener barrier is required to transfer the contact closure into the hazardous area which may be combined with the supply barrier so that only one package is required. A diode return barrier is not suitable for this application. Fig 1 illustrates how a BA377E-SS may be reset from both the safe and the hazardous area.

Note: When used as a Timer the BA377E-SS may also be reset from the display mode by operating the  and  push buttons simultaneously for more than two seconds. See 6.5.19

3.1.9 Control outputs (optional)

Each of the two factory fitted optional control outputs is a galvanically isolated single pole solid state switch as shown in Fig 3. The outputs are polarised and current will only flow in one direction. Terminals A1 and A3 should be connected to the positive side of the supply.

$$R_{on} < 5\Omega + 0.7V$$

$$R_{off} > 1M\Omega$$

Note: Because of the series protection diode some test meters may not detect a closed alarm output

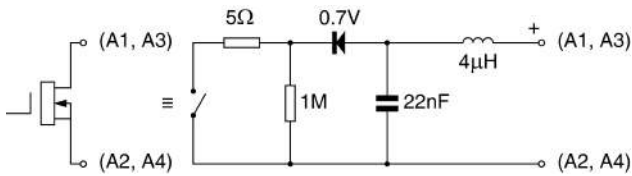

Fig 3 Equivalent circuit of each control output

Each control output is a separate galvanically isolated intrinsically safe circuit with output safety parameters complying with the requirements for *simple apparatus*. This allows the control output terminals A1 & A2 and A3 & A4 to be connected to almost any intrinsically safe circuit protected by a Zener barrier having output parameters equal to or less than:

$$U_o \leq 28V$$

$$I_o \leq 200mA$$

$$P_o \leq 0.84W$$

The maximum equivalent capacitance and inductance between each set of control output terminals is:

$$C_i = 22nF$$

$$L_i = 8\mu H$$

To determine the maximum permissible cable parameters C_i and L_i of the BA377E-SS should be subtracted from the maximum permitted external capacitance C_o and inductance L_o specified by the certificate for the Zener barrier powering the circuit as shown in Fig 4. The internal capacitance and inductance of other devices in the loop, such as the solenoid valve in Fig 4, should also be subtracted from C_o & L_o .

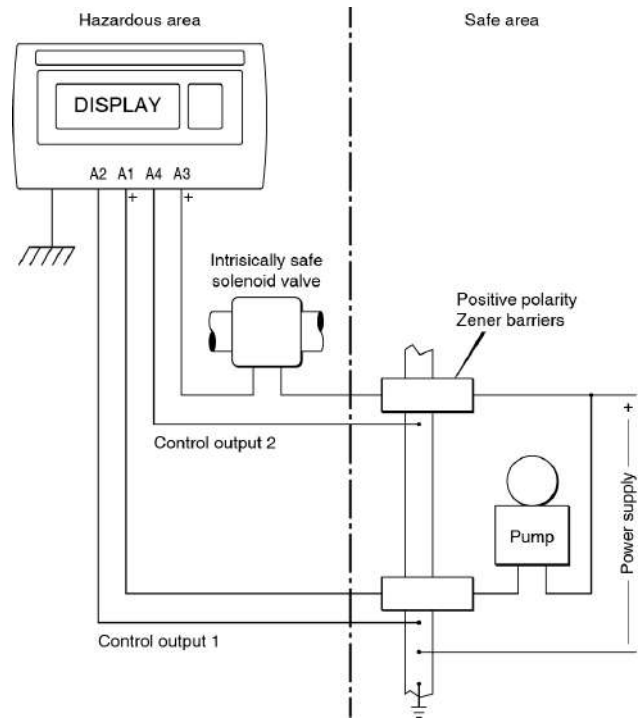

Fig 4 Typical control output application

3.2 Use with Galvanic Isolators

Galvanic isolators are probably the simplest intrinsically safe interface to install as they provide isolation and do not require a high integrity earth connection.

Any galvanic isolator certified for the gas group in which the BA377E-SS is installed, with output parameters less than the input parameters of the BA377E-SS having the correct function may be used.

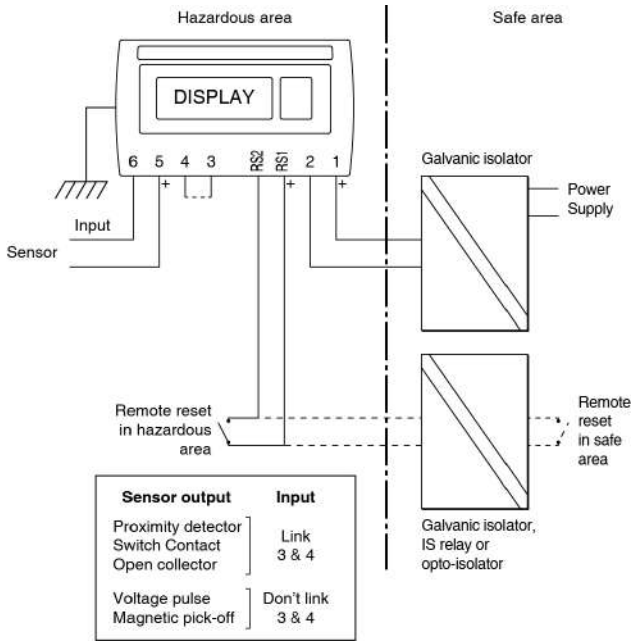

Fig 5 BA377E-SS used with galvanic isolators

Fig 5 illustrates the basic circuit that is used for all BA377E-SS installations protected by galvanic isolators.

Alternatively sensors may be located in the safe area. Fig 6 shows how an additional galvanic isolator is used to transfer the sensor output to the BA377E-SS in the hazardous area, although it may be difficult to find isolators for some types of sensor. The BA377E-SS input energising link should be fitted to suite the output of the galvanic isolator not the sensor.

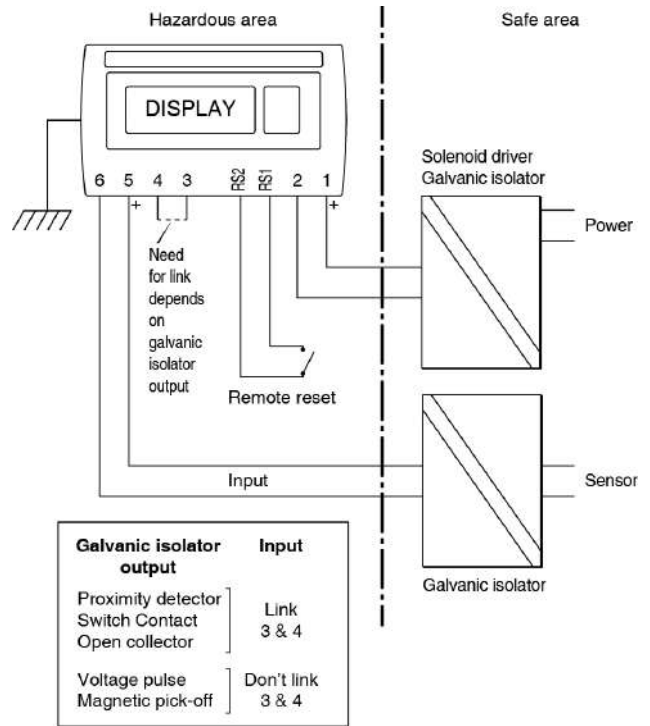

Fig 6 BA377E-SS Timer used with galvanic isolators and input sensor in safe area.

3.2.1 Power supply

The BA377E-SS requires a minimum of 10V between terminal 1 & 2 and consumes:

- 10mA without optional backlight
- plus 22mA with optional backlight
- plus 6mA when terminals 3 & 4 are linked

Any galvanic isolator certified for the gas group and Zone in which the BA377E-SS is installed may be used to power the instrument. The output safety parameters of the isolator must be equal to or less than the input safety parameters of terminals 1 & 2 and the voltage at terminals 1 & 2 must be greater than 10V. These requirements are not restrictive and allow a wide range of galvanic isolators, such as solenoid drivers, to be used.

3.2.2 Sensor inputs

As shown in Fig 5 the BA377E-SS input can be directly connected to hazardous area sensor, or to safe area sensors via isolators as shown in Fig 6. Galvanic isolators are not required in series with the input if the intrinsically safe sensor is located within the same hazardous area as the BA377E-SS. The input must be maintained not momentary.

The BA377E-SS may be used with a wide variety of sensors, the following table shows the switching thresholds for each type. For reliable operation the input signal must fall below the lower threshold and rise above the upper threshold.

Sensor	Switching thresholds	
	Lower	Upper
Low voltage range	1.0V	3.0V
High voltage range	3.0V	10.0V
Proximity detector	1.2mA	2.1mA
Switch	100Ω	1000Ω
Open collector	2kΩ	10kΩ

Switch contacts, proximity detectors and open collector sensors require energising which is achieved by linking two BA377E-SS terminals together as described in section 2.5.

3.2.3 Switch contact input

Any mechanically activated switch contact may be directly connected to input terminals 5 & 6 providing the switch is located in the same hazardous area as the BA377E-SS, and the switch and associated wiring can withstand a 500V rms insulation test to earth. Most magnetically activated industrial push buttons and reed relays comply with these requirements. The BA377E-SS contains a configurable debounce circuit to prevent false triggering of the instrument. Three levels of debounce protection are available. See section 6.5.6

3.2.4 Open collector input

Any open collector sensor located in the same hazardous area as the BA377E-SS, such as a mechanically activated opto-isolator, may be directly connected to input terminals 5 & 6. The sensor and the associated wiring must be able to withstand a 500V rms insulation test to earth.

The BA377E-SS contains a configurable debounce circuit to prevent false triggering. Three levels of debounce protection are available See section 6.5.6

3.2.5 2-wire proximity detector input

Most intrinsically safe NAMUR 2-wire proximity detectors may be connected to the BA377E-SS input, providing the input safety parameters of the proximity detector are equal to or greater than the output safety parameters of a BA377E-SS input. i.e.

U_i	\geq	10.5V dc
I_i	\geq	8.2mA dc
P_i	\geq	25mW

and the minimum operating voltage of the proximity detector is less than 7.5V. The proximity detector must be located in the same hazardous area as the BA377E-SS.

The BA377E-SS contains a configurable debounce circuit to prevent false triggering of the instrument. Three levels of debounce protection are available. See section 6.5.6

3.2.6 Magnetic pick-off input

[0, L in the input configuration menu is a low level voltage input intended for use with an intrinsically safe magnetic pick-off sensor which is not suitable for controlling the BA377E-SS,

3.2.7 Voltage input

Two voltage input ranges are independently selectable in the BA377E-SS configuration menu, $U_{oL\leq 5 L}$ and $U_{oL\leq 5 H}$. When configured for either of the voltage ranges and terminals 3 and 4 are not linked, the input terminals 5 and 6 comply with the requirements for *simple apparatus*. This allows the inputs to be connected to any certified intrinsically safe voltage source within the same hazardous area as the BA377E-SS having output parameters equal to or less than:

$$\begin{aligned} U_o &\leq 28V \text{ dc} \\ I_o &\leq 200\text{mA dc} \\ P_o &\leq 0.84W \end{aligned}$$

The BA377E-SS Timer may therefore be directly connected to and controlled by most certified intrinsically safe high level outputs.



The maximum permitted cable parameters will be defined by the intrinsic safety certification of the voltage source less the BA377E-SS input parameters which are small and can often be ignored.

The BA377E-SS contains a configurable debounce circuit to prevent false triggering of the instrument. Three levels of debounce protection are available. See section 6.5.6

3.2.8 Remote reset

Connecting the external reset terminals RS1 and RS2 together will reset the BA377E-SS when configured as a Timer and synchronise the displayed time when configured as a Clock. Remote resetting may be accomplished by any mechanically operated switch located in the same hazardous area as the instrument providing the switch and the associated wiring can withstand a 500V rms insulation test to earth. No galvanic isolator is required.

A BA377E-SS may also be remotely reset or synchronised from the safe area. Any switch may be used but a galvanic isolator or IS relay is required to transfer the contact closure into the hazardous area. Fig 5 illustrates how a BA377E-SS Timer may be reset from both the safe and the hazardous area.

Note: The BA377E-SS can also be configured to reset when the  and  push buttons are operated simultaneously in the display mode for more than two seconds - see 6.5.19

3.2.9 Control outputs - optional

Each of the two factory fitted optional control outputs is a galvanically isolated single pole solid state switch as shown in Fig 7. The outputs are polarised and current will only flow in one direction. Terminals A1 and A3 should be connected to the positive side of the supply.

$$\begin{aligned} R_{on} &= \text{less than } 5\Omega + 0.7V \\ R_{off} &= \text{greater than } 1M\Omega \end{aligned}$$

Note: Because of the series protection diode some test meters may not detect a closed alarm output

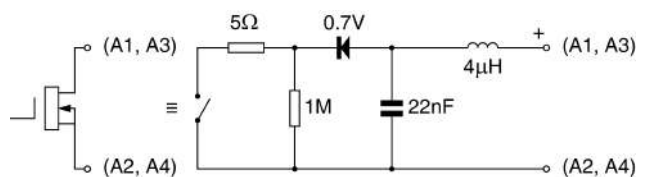

Fig 7 Equivalent circuit of each control output

Each control output is a separate galvanically isolated intrinsically safe circuit with output safety parameters complying with the requirements for *simple apparatus*. This allows the control output terminals A1 & A2 and A3 & A4 to be connected to almost any certified intrinsically safe circuit protected by a galvanic isolator providing the isolator has the correct function and the output parameters do not exceed:

$$\begin{aligned} U_o &\leq 28V \\ I_o &\leq 200\text{mA} \\ P_o &\leq 0.84W \end{aligned}$$

The maximum equivalent capacitance and inductance between each set of alarm terminals is:

$$\begin{aligned} C_i &= 22\text{nF} \\ L_i &= 8\mu\text{H (Effectively 0)} \end{aligned}$$

To determine the maximum permissible cable parameters C_i and L_i , plus those for any other intrinsically safe instruments in the loop, should be subtracted from the maximum permitted external capacitance C_o and inductance L_o specified by the certificate for the galvanic isolator powering the circuit as shown in Fig 8.

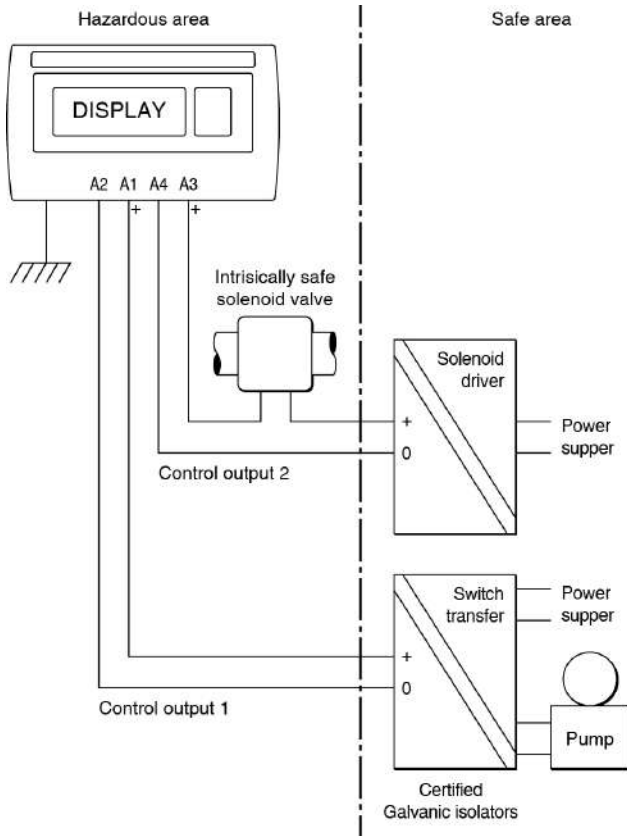

Fig 8 Typical control output application

3.3 Use in an Ex e or Ex p panel enclosure located in Zone 1 or Zone 2.

The BA377E-SS ATEX EC-Type Examination Certificate allows the Timer or Clock to be installed in an Ex e IIC Gb increased safety panel enclosure located in Zone 1 or 2, or in an Ex p IIC Gb pressurised panel enclosure located in a Zone 1 or 2 hazardous area. The BA377E-SS may also be installed in an Ex n enclosure located in Zone 2.

When installed in a certified panel enclosure the BA377E-SS Timer or Clock remains intrinsically safe and must be protected by a Zener barrier or galvanic isolator as described in sections 3.1 and 3.2. When correctly installed, the BA377E-SS Timer or Clock does not invalidate the certification of the Ex e, Ex n or Ex p panel enclosure allowing installation with higher power control equipment.

3.3.1 Installation in an Ex e panel enclosure within Zone 1 or Zone 2.

Installation of a BA377E-SS Timer or Clock in an Ex e IIC Gb increased safety panel enclosure does not invalidate the Ex e panel's ingress and impact protection as the front of the BA377E-SS complies with Ex e impact and ingress requirements. Although mounted in an Ex e panel enclosure, the BA377E-SS remains Group II Category 1G Ex ia IIC T5 Ga intrinsically safe apparatus therefore it must be powered via a Zener barrier or galvanic isolator as described in section 3.1 and 3.2 of this manual.

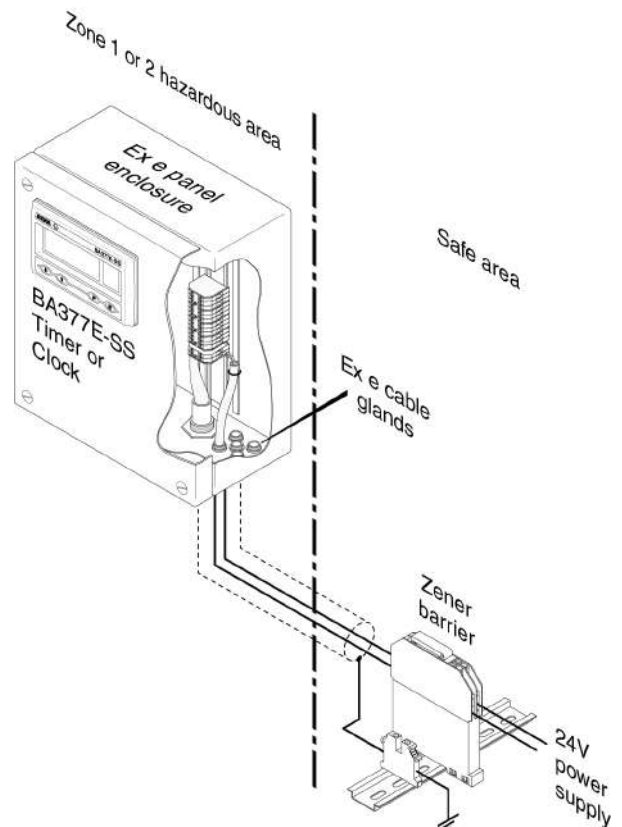

Fig 9 Typical installation in Ex e panel enclosure

Some Zener barriers and galvanic isolators are certified for mounting within a protective enclosure located in Zone 2 which may permit them to be mounted in the same Ex e enclosure as the BA377E-SS Timer or Clock. Zener barriers and galvanic isolators are not permitted in Ex e enclosures located in Zone 1.

The Timer or Clock terminals, the wiring to the Timer or Clock and the intrinsically safe interface, if mounted within the enclosure, should be segregated from all other non-intrinsically safe wiring and equipment within the panel enclosure as required by EN 60079-11 *Equipment protected by intrinsic safety* and EN 60079-14 *Electrical installations design, selection and erection*.

The Ex e panel enclosure should be fitted with a warning label saying 'Do not open when non-intrinsically safe circuits are energised', alternatively all bare live non-intrinsically safe parts within the panel enclosure should have an IP30 cover carrying a warning label 'Do not open when energised'.

The power dissipation within an BA377E-SS fitted with operational alarms and a backlight is normally about 350mW. In the very unlikely event that all three circuits fail to the worst case condition at the same time, the total power dissipation rises to 2.5W which could raise the internal temperature of a small thermally well insulated panel enclosure.

3.3.2 Installation in Ex p panel enclosure within Zone 1 or Zone 2.

Installation of a BA377E-SS Timer or Clock in an Ex p IIC Gb or Ex p IIC Gc pressurised panel enclosure does not invalidate the Ex p panel's impact and ingress protection as the front of the Timer or Clock complies with Ex p impact and ingress requirements. Although mounted in an Ex p panel enclosure, the BA377E-SS remains Group II Category 1G Ex ia IIC T5 Ga intrinsically safe apparatus and must therefore be powered via a Zener barrier or galvanic isolator as described in section 3.1 and 3.2 of this manual.

When installed in an Ex p panel enclosure the four vents at the rear of the Timer or Clock which are shown in Fig 13 should not be obstructed.

Zener barriers and galvanic isolators may be installed in the same Ex p enclosure as the BA377E-SS. All may be mounted in an Ex px enclosure installed in Zones 1 or 2, or in an Ex pz enclosure installed in Zone 2, both of which have a non-hazardous interior. Some Zener barriers and galvanic isolators may have certification permitting installation within an Ex py enclosure which has a Zone 2 interior.

The Timer or Clock's terminals, the wiring to the Timer or Clock and the intrinsically safe interface, if mounted within the enclosure, should be segregated from all other non-intrinsically safe wiring and equipment within the panel enclosure as required by EN 60079-11 *Equipment protected by intrinsic safety* and EN 60079-14 *Electrical installations design, selection and erection*.

If live maintenance is anticipated, it is recommended that the Ex p panel enclosure should be fitted with a warning label saying 'Do not open when non-intrinsically safe circuits are energised', alternatively all bare live non-intrinsically safe parts within the panel enclosure should have an IP30 cover carrying a warning label 'Do not open when energised'.

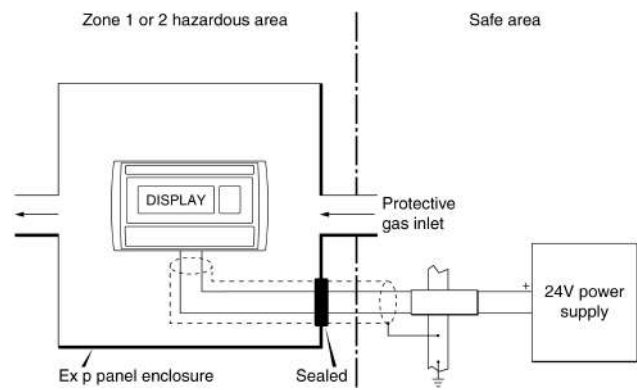

Fig 10 Typical installation in Ex p panel enclosure

4. INSTALLATION

4.1 Location

The BA377E-SS has a stainless steel case with a 10mm thick toughened glass window. The case provides 7J and the window 4J front of panel impact protection. The captive silicone gasket, which seals the joint between the instrument and the panel enclosure, ensures IP66 front of panel ingress protection. The rear of the Timer or Clock has IP20 protection.

Although the front of the BA377E-SS has IP66 protection, it should be shielded from continuous direct sunlight and severe weather conditions.

The BA377E-SS may be located in Zone 0, 1 or 2 providing that the operating temperature is between -40°C and $+60^{\circ}\text{C}$ and the installation complies with the certification requirements.

Installation in Ex e and Ex p panel enclosures are described in sections 3.3.1 and 3.3.2.

Fig 11 show the overall dimensions of the BA377E-SS together with the recommended panel enclosure cut-out dimensions and Fig 13 shows the terminal locations.

4.2 Installation Procedure

- Cut the aperture specified in Fig 11 in the panel enclosure. Ensure that the edges of aperture are de-burred.
- Inspect the Timer or Clock's captive gasket and ensure that it is not damaged before inserting the Timer or Clock into the panel enclosure aperture.
- If the enclosure panel is less than 1.0mm thick, or is non-metallic, an optional BEKA stainless steel support plate should be slid over the rear of the Timer or Clock before the panel clamps are fitted to evenly distribute the clamping force and prevent the enclosure panel being distorted or creeping.
- Slide a panel clamp into the two grooves at each corner of the indicator housing with the M3 stud protruding through the hole at the rear of the clamp. Fit the stainless steel spring washer over the stud and secure with the stainless steel wing nut.
- Evenly tighten the four clamps to secure the instrument. The recommended minimum tightening torque for each wing nut is 22cNm (1.95 lbf in).
- Connect the panel enclosure wiring to the rear terminal blocks as shown in Fig 13. To simplify installation, the terminals are removable so that wiring can be completed before the instrument is installed. Cables should be mechanically secured to ensure terminals are not damaged by vibration.

- Finally, fit a silicone rubber push-on cap to the end of each M3 threaded rod.

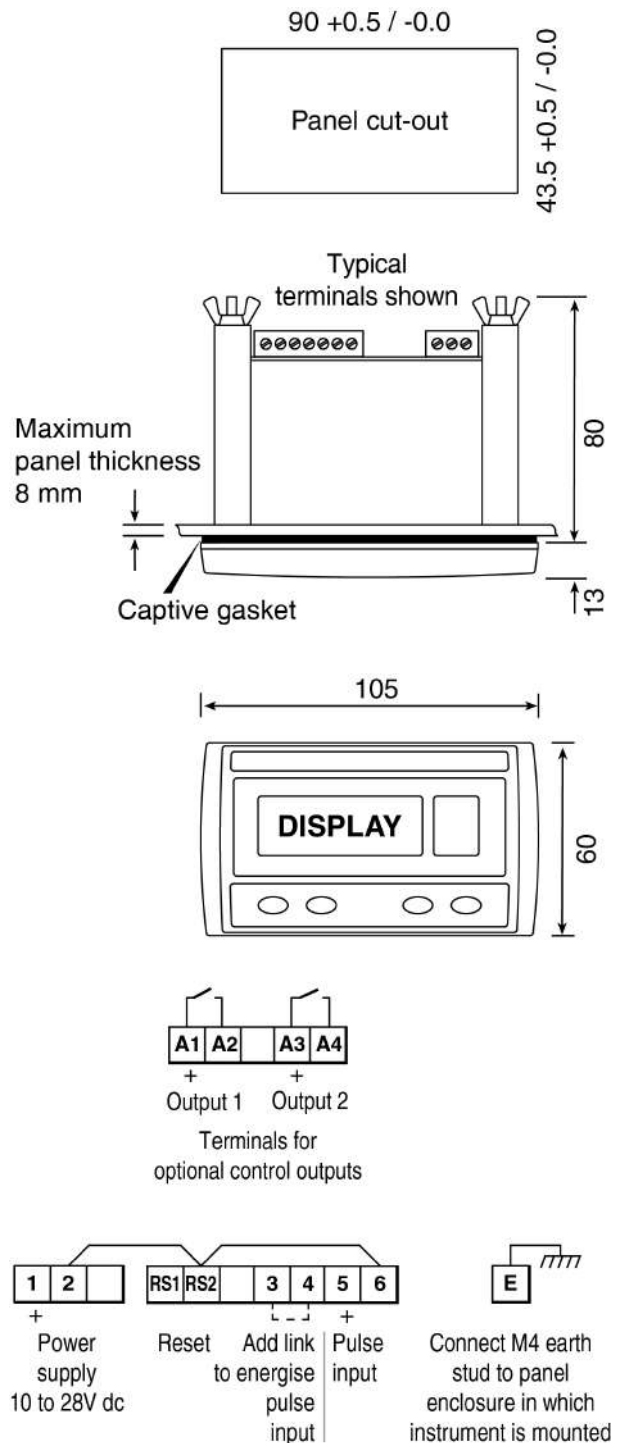

Support panel wiring to prevent vibration damage

Note: Optional backlight is internally powered

Fig 11 Dimensions

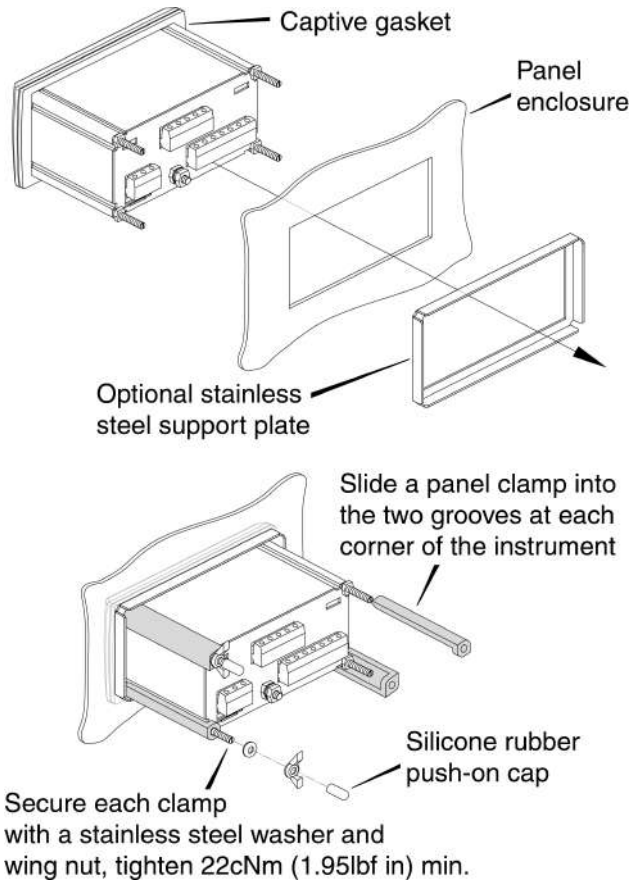

Fig 12 Installation procedure

4.3 EMC

The BA377E-SS complies with the requirements of the European EMC Directive 2014/34/EU. For specified immunity all wiring should be in screened twisted pairs, with the screens earthed at one point within the safe area.

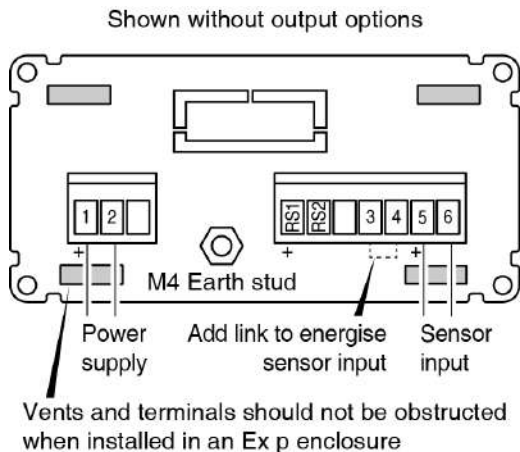

Fig 13 terminal

4.4 Timer or Clock earthing

The BA377E-SS has an M4 earth stud on the rear panel which should be electrically connected to the panel enclosure in which the instrument is mounted, or to the plant equipotential conductor.

4.5 Scale card

The Timer or Clock's units of measurement are shown on a printed scale card in a window at the right hand side of the display. The scale card is mounted on a flexible strip that is inserted into a slot at the rear of the instrument as shown in Fig 14. Thus the scale card can easily be changed without removing the Timer or Clock from the panel or opening the instrument enclosure.

New Timer or Clocks are supplied with a printed scale card showing the requested units of measurement, if this information is not supplied when the instrument is ordered a blank card will be fitted.

A pack of self-adhesive scale cards printed with common units of flow measurement is available as an accessory from BEKA associates. Custom printed scale cards can also be supplied.

To change a scale card, unclip the tapered end of the flexible strip at the rear of the instrument by gently pushing it upwards and pulling it out of the enclosure. Peel the existing scale card from the flexible strip and replace it with a new printed card, which should be aligned as shown below. Do not fit a new scale card on top of an existing card.

Install the new scale card by gently pushing the flexible strip into the slot at the rear of the Timer or Clock, when it reaches the internal end-stop secure it by pushing the end of the flexible strip downwards so that the tapered section is held by the rear panel.

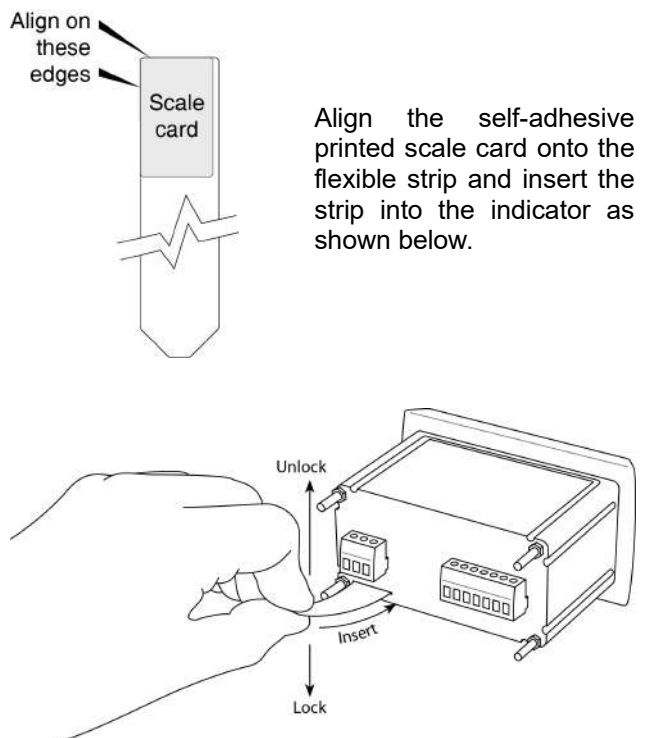

Fig 14 Inserting the flexible strip carrying the scale card into the slot at rear of instrument.

5. ACCESSORIES

5.1 Display backlight

The BA377E-SS Timer and Clock can be supplied with a factory fitted backlight that produce green illumination enhancing display contrast and enabling it to be read at night or in poor lighting conditions. The backlight is internally powered from the instrument power supply so no additional wiring or intrinsically safe interface is required, but the supply current increases as shown below.

	BA377E-SS Timer current consumption
Without backlight	10mA
Additional for backlight	22mA
Addition with terminals 3 & 4 linked	6mA

Total current	38mA max

5.2 Control outputs

Although the dual isolated control outputs are factory fitted options, they are described in the main body of this instruction manual as they will be used for the majority of Timer applications. If control outputs are required they should be specified when the instrument is ordered.

5.3 Scale card

The BA377E-SS has a window on the right hand side of the display through which a scale card showing the units of measurement such as hours can be seen. New instruments are fitted with a scale card showing the units of measurement specified when the instrument was ordered, if the units are not specified a blank scale card will be fitted. A pack of scale cards pre-printed with common units of measurement is available as an accessory. These can easily be fitted on-site without opening the instrument enclosure or removing it from the panel. See section 4.5 of this instruction manual.

Custom scale cards for applications requiring less common units of measurement are also available.

5.4 Tag information

New instruments can be supplied with a tag number or application information printed onto the rear panel adjacent to the terminals. This information is not visible from the front of the instrument after installation.

5.5 Rear cover sealing kit

The BA377E-SS Timer or Clock's rear of panel ingress protection can be increased from IP20 to IP66 with a BA495 rear cover sealing kit. Manufactured from 316 stainless steel the cover incorporates two M20 unthreaded entries for cable glands.

It allows the BA377E-SS Timer or Clock to be installed as an intrinsically safe instrument in an open panel or to provide additional rear protection when installed within an Ex e enclosure.

Note: The BA495 rear cover is not certified to provide Ex e protection, it only increases the instrument's rear protection to IP66.

6. OPERATION AS A TIMER

When configured as a Timer the BA377E-SS can measure and display the elapsed time between external events such as measuring and displaying how long machinery is operating. The Timer can be started and stopped by a remote sensor with a continuous output, or from the front panel push buttons.

The addition of two optional factory fitted isolated control outputs allows the Timer to control external events such as opening a valve for a predetermined time. Again the Timer can be started and stopped by a remote sensor, or from the front panel push buttons.

When controlling external events the [Y][E] function enables the BA377E-SS Timer to be configured to repeat the timing period up to 99 times with a configurable delay between timed periods up to 100 hours or to repeat continuously.

The BA377E-SS may be configured to *time-up* from zero to the set time 5E± t, or to *time-down* from the set time to zero. The set time may be entered and displayed in hours, minutes or seconds, or a combination of units. Elapsed or remaining time is continuously displayed and a separate display may be activated to show the Timer set time 5E± t. Resetting the timer cycle can be accomplished via the front panel push buttons or by a remote contact.

A grand total time is maintained which can be viewed by operating the front panel push buttons. It may be reset to zero from within the configuration menu, or the instrument may be configured to allow resetting from the front panel push buttons.

Fig 15 shows a simplified block diagram of the BA377E-SS when configured as a Timer. The input can be configured to accept inputs from a wide variety of sensors. When the sensor requires energising, such as a switch contact, open collector or a two wire proximity detector, a link connected between terminals 3 & 4 supplies power to the sensor input.

The instrument can be supplied with the following factory fitted accessories:

Internally powered Backlight

Dual isolated Control Outputs

The two factory fitted solid state isolated control outputs may be independently configured to close and open at specified parts of the timer cycle, such as when the timer starts or finishes.

6.1 Initialisation

Each time power is applied to a BA377E-SS initialisation is performed. After a short delay the following display sequence occurs:

All segments of the display are activated

BA377E-SS is ready to start functioning using the configuration information stored in the instrument's permanent memory.

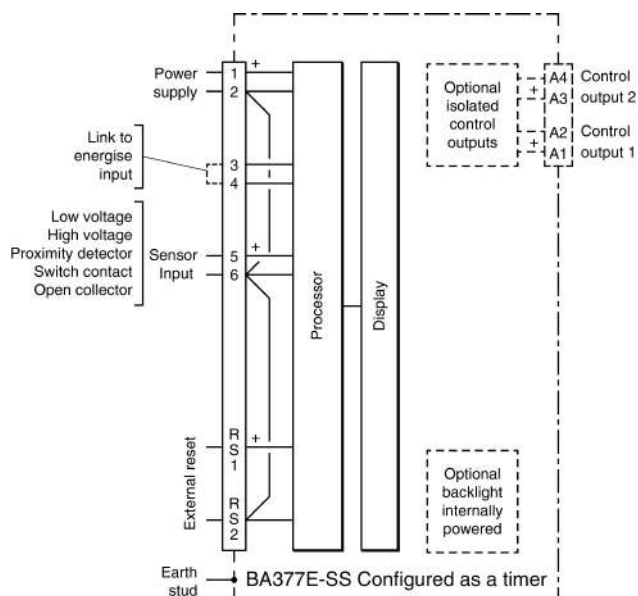



Fig 15 BA377E-SS block diagram with Timer configuration.



6.2 Controls when configured as a Timer





The BA377E-SS is controlled and configured via four front panel push buttons. In the display mode i.e. when the instrument is displaying time the push button functions are:



Push Button Functions



 When local control is enabled starts the Timer. See 6.5.8



 When local control is enabled stops the Timer. See 6.5.8

 +  Shows the grand total (run time) in hours and tenths of an hour irrespective of Timer configuration. If buttons are held for longer than ten seconds the grand total may be reset to zero if the grand total reset sub-function $\text{ELR } \text{E} \text{t} \text{e} \text{t}$ is enabled in the $\text{L} \text{a} \text{r} \text{r} \text{5E} \text{t}$ configuration function. See 6.5.20



To reset the grand total to zero from the display mode press the  +  buttons for ten seconds until $\text{ELR} \text{.} \text{no}$ is displayed, using the  or  button change the display to $\text{ELR} \text{.} \text{yE} \text{5}$ and press .

 +  Resets the Timer to zero or to the set time $\text{5E} \text{t} \text{ t}$ depending on whether the Timer is configured to *time-up* or *time-down* when the two buttons are operated simultaneously for more than three seconds. This is a configurable function. See 6.5.19

 +  When enabled in the configuration menu, operating these two buttons simultaneously provides direct access to the set time $\text{5E} \text{t} \text{ t}$ and allows adjustment when the timer is in the display mode. See 6.5.15

 +  Shows in succession, firmware version number, instrument function $\text{ELRP} \text{5E}$ and any output accessories that are fitted:

-R Dual Control Outputs

 +  Access to configuration menu

6.3 Displays when configured as a Timer

The BA377E-SS has two digital displays and associated annunciators as shown on page 1.

Elapsed time The upper display shows the elapsed time since the Timer was started when *timing-up* from zero and the remaining time when *timing-down* from the set time. The display may be formatted as hh:mm:ss; hh:mm; mm:ss or ss.

Lower display The display options available on the lower display depend on whether the Timer repeat cycle function $\text{CYCLE} \text{5}$, which can repeat the timing period up to 99 times, or continuously with a configurable delay between periods, is enabled.

CYCLE5 disabled

The lower display shows the set time $\text{5E} \text{t} \text{ t}$, or the lower display may be disabled if not required. See 6.5.7

CYCLE5 enabled

The lower display shows the total number of repeat cycles requested together with the number of the current cycle. Each operation may be briefly named at it's start or periodically throughout the cycle. The lower display may also be disabled if not required. See 6.5.7

Reset annunciator

Activated while elapsed time is being reset to zero or to the set time $\text{5E} \text{t} \text{ t}$.

Grand total annunciator



Activated when the grand total time is being shown on the upper display.

Control output annunciators

Show status of both optional control outputs.

6.4 Timer structure

Fig 16 illustrates the Timer structure and function. It applies when the instrument is measuring the time between events or is controlling external events.

The circles in Fig 16 represent the five Timer states, *Reset*, *Running*, *Restart-delay*, *Paused* and *Complete*. The lines between the circles represent the event required to move the Timer between states. e.g. to initiate timing the Timer is moved from the *Reset* state to the *Running* state by a start event. This could be an input signal or operation of the  button. Similarly, to pause the Timer while it is timing, the Timer must be moved from the *Running* state to the *Pause* state by a stop event which could be an input or operation of the  button.

Reset

In this state the Timer is readied for operation. The Timer is stopped and loaded with zero for timing-up or 5E \bar{t} for timing-down.

Running

Entered by a start event from the *Reset* or *Paused* states. The Timer times-up to 5E \bar{t} or times-down to zero depending upon it's configuration.

Pause

Entered by a stop event from *Running* or *Restart-delay*. Timer is stopped, a start event returns the timer to it's previous state.

Restart-delay

Entered automatically from *Running*. At the end of the delay time automatically returns to *Running*.

Complete

Entered automatically from *Running* when there are no more timing cycles to perform.

When the $\bar{C}Y\bar{C}L\bar{E}S$ function is enabled the timing cycle can be repeated a specified number of times, or continuously.

6.5 Configuration as a Timer

The BA377E-SS is configured via the four front panel push buttons. All the configuration functions are contained in an easy to use intuitive menu that is shown diagrammatically in Fig 17.

Each menu function is summarised in section 6.5.2 of this manual and each summary includes a reference to more detailed information.

All new BA377E-SS instruments are supplied configured as requested at the time of ordering. If configuration is not requested, the BA377E-SS will be supplied with default Timer configuration as shown below, but the instrument can easily be re-configured on-site.

Function	Display	Default
Access code	$\bar{C}odE$	0000
Function	$Fun\bar{C}t, on$	ELAPSE
Input	$inPut$	$\bar{o}P.\bar{C}oL$
Debounce	$dEboun\bar{C}E$	$dEFRuL\bar{t}$
Display 2	$d, SP-2$	5 $\bar{t}d$
Start stop	$StArStoP$	$L\bar{o}CRL$
Units	un, tS	12:00:00
Set time	5E \bar{t} \bar{t}	00:00:00
Enable repeat cycle	$\bar{C}Y\bar{C}L\bar{E}S$	$\bar{o}FF$
Access set time from display mode.	$R\bar{C}SE\bar{t}$ \bar{t}	$\bar{o}FF$
Direction of count	$uP or dn$	dn
Recovery from power supply failure.	$P-FR, L$	dLE
Local total reset	$\bar{t}-rESE\bar{t}$	on
Local grand total reset	$\bar{G}\bar{t}-rESE\bar{t}$	$\bar{o}FF$
External reset	$E-rSE\bar{t}$	5 $\bar{t}d$
Enable control output 1 *	$E\bar{n}bL$	$\bar{o}FF$
Enable control output 2 *	$E\bar{n}bL$	$\bar{o}FF$

* Optional output

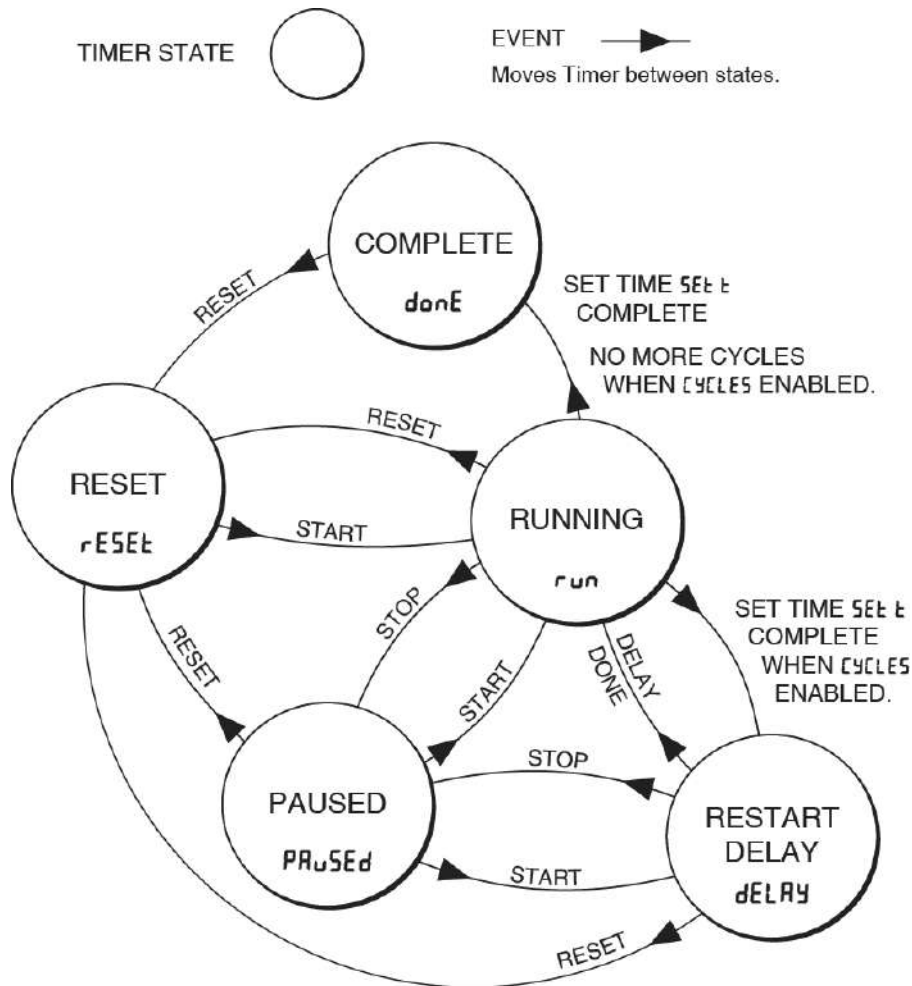







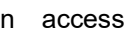











Fig 16 Timer structure showing states and events



6.5.1 Accessing configuration functions

Throughout this manual front panel push buttons are shown as , ,  and  and legends displayed by the instrument are shown in a seven segment font just as they appear on the instrument e.g.  and .

Access to the configuration menu is obtained by operating the  and  push buttons simultaneously. If the instrument is not protected by an access security code the first parameter  will be displayed. If a security code other than the default code  has already been entered, the instrument will display . Press  to clear this prompt and enter the security code for the instrument using the  or  push button to adjust the flashing digit and the  push button to transfer control to the next digit. If the correct code has been entered pressing  will cause the first parameter  to be displayed. If an incorrect code is entered, or a push button is not operated within ten seconds, the instrument will automatically return to the display mode.

All configuration functions and prompts are shown on the upper eight digit display.

Once within the main configuration menu the required function can be selected by scrolling through the menu using the  and  push buttons. The Timer configuration menu is shown diagrammatically in Fig 17.

When returning to the display mode following reconfiguration, the Timer will display  followed by  while the new information is stored in permanent memory.

6.5.2 Summary of Timer configuration functions

This section summarises all the Timer configuration functions. When read in conjunction with Fig 17 it provides a quick aid for configuring the Timer. If more detail is required, each section of this summary contains a reference to a full description of the function.

Display	Summary of function
Funct, on	<p>Instrument function Defines the function of the instrument. May be set to:</p> <p>ELRPSE Timer configuration CLoC Clock configuration</p> <p>All the entries in this Timer summary assume that the BA377E-SS is configured as a Timer by selecting ELRPSE. See section 6.5.3</p>
Input	<p>Configuration of Input Contains a sub-menu with two sub-functions:</p> <p>InputTYPE Selects input sensor type DEBOUNCE Defines input debounce</p> <p>InputTYPE Configures the Timer sensor input to accept one of six types of input:</p> <p>Open collector • Voltage <1 >3V Voltage <3 >10V Proximity detector • Switch contact •</p> <ul style="list-style-type: none"> Energise input by linking terminals 3 & 4. <p>See section 6.5.5</p> <p>DEBOUNCE Defines the level of debounce applied to the input to prevent false functioning:</p> <p>DEFALt HEAVY LIGHT</p> <p>See section 6.5.6</p>

Display	Summary of function												
d, SP-2	<p>Lower display Configures the lower display to show set time SEt t or, when the CYCLE5 repeat function is activated, the restart delay count-down plus the cycle count number.</p> <p>With CYCLE5 not enabled:</p> <p>Select Lower display shows</p> <p>Setd Set time SEt t</p> <p>oFF Disables lower display. See section 6.5.7</p> <p>With CYCLE5 enabled:</p> <p>Select Lower display shows</p> <p>Setd Cycles requested and cycles performed with time-down shown during requested delay period. Brief notification of timer status i.e. CYCLE or DELAY at start of each period.</p> <p>LRbEL Exactly as Setd but with periodic notification of timer status i.e. CYCLE or DELAY.</p> <p>oFF Disables lower display. See section 6.5.7</p>												
Start-Stop	<p>Starting and stopping the timer Defines how the Timer is started and stopped.</p> <table border="1"> <thead> <tr> <th></th> <th>Start</th> <th>Stop</th> </tr> </thead> <tbody> <tr> <td>LoAL</td> <td>▼ button</td> <td>▲ button</td> </tr> <tr> <td>Control 1</td> <td>Input high</td> <td>Input low</td> </tr> <tr> <td>Control 2</td> <td>Input low</td> <td>Input high</td> </tr> </tbody> </table> <p>High and low inputs are specified for a continuous voltage input. For other types of sensor input. See section 6.5.8</p>		Start	Stop	LoAL	▼ button	▲ button	Control 1	Input high	Input low	Control 2	Input low	Input high
	Start	Stop											
LoAL	▼ button	▲ button											
Control 1	Input high	Input low											
Control 2	Input low	Input high											

Display	Summary of function	Display	Summary of function
un, t5	<p>Units of display Selects displayed units.</p> <p>12:00:00 Hours, minutes & seconds 12:00 Hours & minutes * 30:00 Minutes & seconds 30 Seconds</p> <p>Excludes delay of optional control outputs which is always shown in seconds and the grand total which is always shown in hours. * Only available if 5Et t and r5t dELR, if already entered, specify zero seconds or seconds which are exactly divisible by sixty. See section 6.5.9</p>	uP or dn	<p>Direction of count Defines whether the Timer <i>times-down</i> from 5Et t to zero or <i>times-up</i> from zero to the set time 5Et t. See section 6.5.16</p>
5Et t	<p>Set time When controlling an external event via the optional control outputs the BA377E-SS will <i>time-down</i> from the set time to zero or <i>time-up</i> from zero to the set time. Note: Timer will only start if a non zero value is entered for set time 5Et t. See section 6.5.10</p>	P-FR, L	<p>Power Failure Defines how the Timer functions when power is restored after a power failure. Contains three sub-functions, t dLE, PRuSE and Cnt, nuE.</p> <p>t dLE Timer returns in stopped state as if having completed a single timing cycle displaying Timer value when power was lost. Timing resumes when reset followed by start instructions are received.</p> <p>PRuSE Timer returns in paused state displaying Timer value when power was lost. Timing resumes when start instruction is received.</p> <p>Cnt, nuE Timer will continue without any manual intervention. See section 6.5.17</p>
CYCLE5	<p>Repeat timing cycle Contains a sub-menu with three sub-functions, EnbL, CYCL Cnt and r5t dELR. See section 6.5.11</p> <p>Cycle function enable EnbL Enables or disables the CYCLE5 function without changing the parameters. See section 6.5.12</p> <p>Cycle count CYCL Cnt Defines the number of times that the timer cycle is repeated. See section 6.5.13</p> <p>Restart delay r5t dELR Defines the time delay between timer cycles. See section 6.5.14</p>	LoC r5Et	<p>Local reset Contains two sub-functions which when enabled allow the Timer and the grand total, which represents total Timer run-time, to be reset to zero via the front panel push buttons while the Timer is in the display mode. See section 6.5.18</p> <p>Local total reset r5EtEnbL When on is selected, Timer is reset to zero, or 5Et t if <i>timing-down</i>, when the ▼ and ▲ buttons are operated simultaneously for more than 2 seconds in the display mode. See section 6.5.19</p> <p>Local grand total reset CLR Gtnt When on is selected the grand total, which represents total run-time, may be reset to zero by operating the E + ▲ buttons simultaneously for more than 10 seconds in the display mode. Note: Once reset, the grand total can not be recovered. See section 6.5.20</p>
RC5Et t	<p>Access 5Et t and r5t dELR from display mode. Enables 5Et t and r5t dELR to be adjusted from the display mode. Also contains a sub-function RCLd which defines a separate code to protect access from the display mode to 5Et t and r5t dELR. See section 6.5.15</p>		

Display	Summary of function	Display	Summary of function
oP1	<p>Control output 1 (Optional) Contains sub-menu with four sub-functions, <i>EnbL</i>, <i>oP1 on</i>, <i>oP1 off</i> and <i>oP1 dELR</i>. See section 6.5.21</p> <p>Control output enable <i>EnbL</i> Enables or disables control output 1 without changing the parameters. See section 6.5.22</p> <p>Control output 1 on at <i>oP1 on</i> Defines when the control output turns on (closes). See section 6.5.23</p> <p>Control output 1 off at <i>oP1 off</i> Defines when the control output turns off (opens). See section 6.5.24</p> <p>Control output 1 delay <i>oP1 dELR</i> Introduces a configurable delay between the <i>oP1 on</i> condition occurring and the control output turning on (closing). See section 6.5.25</p>	r5E5 dEF	<p>Reset to factory defaults Resets the BA377E-SS to the factory default configuration shown in section 6.5 when <i>5E5</i> is selected and confirmed by entering <i>5urE</i>. See section 6.5.29</p>
oP2	<p>Control output 2 (Optional) Functions as control output 1. See section 6.5.26</p>		
ELr Gtot	<p>Resets grand total to zero This function resets the grand total, which represents the total Timer runtime, from within the configuration menu when <i>ELr 5E5</i> is selected and <i>5urE</i> is entered to confirm the instruction. Note: Once reset, the grand total can not be recovered. See section 6.5.27</p>		
Code	<p>Security code Defines a four digit alphanumeric code that must be entered to gain access to the instrument's configuration menu. Default code <i>0000</i> disables the security function and allows unrestricted access to all configuration functions when the P and E buttons are operated simultaneously in the display mode. See section 6.5.28</p>		

6.5.3 Instrument function: *Funct, on*

The BA377E-SS may be configured as a Timer or as a Clock. This section of the instruction manual describes the Timer, for details of Clock configuration see section 9.

To reveal the existing function of the instrument select *Funct, on* from the configuration menu and press **[P]**. If *ELRPSE* is displayed, the instrument is already configured as a Timer therefore press **[E]** to return to the *Funct, on* prompt in the configuration menu. If *ELoC* is displayed, press the **[▲]** or **[▼]** button to change the setting to *ELRPSE* followed by the **[P]** button which will result in a *0000* prompt being displayed with the first digit flashing. This is a request for the instruction to be confirmed by entering *SurE* using the **[▼]** and **[▲]** buttons to adjust the flashing digit and the **[P]** button to move control to the next digit. When *SurE* has been entered, pressing **[E]** will reconfigure the instrument to a Timer and return the display to *Funct, on* in the configuration menu.

6.5.4 Input: *Input*

The *Input* function contains two sub-functions *InputType* which defines the type of sensor that may be connected to the input and *debounce* which adjust the amount of input noise rejection.

6.5.5 Input type: *InputType*

InputType is a sub-menu in the *Input* function which defines the type of input sensor that may be connected to the input. To check or change the type of input, select *Input* in the configuration menu and press **[P]** which will reveal the *InputType* prompt, pressing **[P]** again will show the existing input type. If set as required press **[E]** twice to return to the configuration menu, or repeatedly press the **[▲]** or **[▼]** button until the required type of input is displayed and then press **[E]** twice to return to the configuration menu.

One of following six types of input may be selected:

Display	Input type	Switching thresholds	
		Low	High
<i>oPCoL</i>	Open collector ²	2	10kΩ
<i>VoLtoL</i>	Voltage range low ¹	1	3V
<i>VoLtoH</i>	Voltage range high ¹	3	10V
<i>Pr.dEt</i>	Proximity detector ²	1.2	2.1mA
<i>CotRCoL</i>	Switch contact ²	100	1000Ω

Notes:

1. Maximum voltage input +28V.
2. For sensors that require energising i.e. proximity detectors, switch contacts and those with open collector outputs, terminals 3 & 4 of the BA377E-SS Timer should be linked together.
3. For the Timer to function correctly, the input signal must fall below the lower switching threshold and rise above the higher switching threshold for the times shown in the debounce section 6.5.6 below.

6.5.6 debounce: *debounce*

debounce is an adjustable sub-menu in the *Input* function which prevents the Timer malfunctioning when the input has noisy edges, such as those resulting from a mechanical contact closing and bouncing. Three levels of protection may be selected and the amount of debounce applied depends upon the type of Timer input that has been selected in the *InputType* function.

The following table shows the minimum time that the input signal must be continuously above the upper input switching threshold and continuously below the lower switching threshold to ensure that the Timer processes the input signal. Input switching thresholds are shown in section 6.5.5.

Debounce level	Min continuous input	
	Type of Input	
	Contact	All others
Default	1600µs	40µs
Heavy	3200µs	350µs
Light	400µs	5µs

6.5.7 Lower display: *d, 5P-2*

The configuration of the lower display which has six 12mm high digits, depend upon whether the repeat timer function *CYCLE5*, which can repeat the timing period up to 99 times or continuously with a configurable delay between periods, is enabled. The configuration options are:

CYCLE5 disabled

The lower display shows the set time *5E t* or the lower display may be disabled.

CYCLE5 enabled

The lower display shows the total number of repeat cycles requested together with the current cycle number. During the configurable delay between cycles the display times-down from the requested delay time to zero. Each operation may be briefly named at it's start or periodically throughout the cycle.

The lower display may also be disabled if not required.

To check or change the configuration of the lower display select *d, 5P-2* from the configuration menu and press **[P]** which will reveal the existing setting which can be changed by pressing the **[▲]** or **[▼]** button followed by the **[E]** button to enter the selection and return to the configuration menu.

If the *CYCLE5* function is not enabled the following two options are available:

5td Lower display shows the Timer's set time *5E t*, from which the BA377E-SS will time-up or time-down depending upon the direction of count selected in the *uP* or *dn* function.

oFF Lower display disabled.

If the *CYCLE5* function is enabled the following three options are available:

5td Lower display shows the number of cycles requested together with the current cycle number. During the configurable delay period the display times-down from the requested delay to zero. A brief notification of timer status i.e. *CYCLE* or *dELAY* is shown at start of each period.

02 - 11

Current cycle number Number of cycles requested, not shown when cycle is continuously repeated.

LABEL Exactly the same as *5td*, but timer status i.e. *CYCLE* or *dELAY* is shown periodically.

oFF Lower display disabled.

6.5.8 Starting & stopping the Timer: *5tAr5toP*

The Timer may be started and stopped by a continuous sensor input signal or by operation of the front panel **[▲]** or **[▼]** push buttons. To check or change the control of the Timer, select *5tAr5toP* from the configuration menu and press **[P]** which will reveal the existing setting which can be changed by pressing the **[▲]** or **[▼]** button followed by the **[E]** button to enter the selection and return to the configuration menu. Options available are:

Voltage inputs or control from front panel

Display	Start	Stop
<i>Control 1</i>	Input high	Input low
<i>Control 2</i>	Input low	Input high
<i>LoARL</i>	[▼] button	[▲] button

Contact and open collector inputs

Display	Start	Stop
<i>Control 1</i>	Open	Closed
<i>Control 2</i>	Closed	Open

Proximity detector input

Display	Start	Stop
<i>Control 1</i>	Low current	High current
<i>Control 2</i>	High current	Low current

6.5.9 Units of display: $\mu n, t5$

Defines the format of all displayed times, except the delay time of the optional control outputs which is shown in seconds and the grand total which is shown in hours and tenths of an hour.

To check or change the units of display, select $\mu n, t5$ from the configuration menu and press P which will reveal the existing setting. The required units can be selected by pressing the \blacktriangle or \blacktriangledown button followed by the E button to enter the selection and return to the configuration menu. The options available are shown below:

Display	
12:00:00	Hours, minutes & seconds
12:00	Hours & minutes*
30:00	Minutes & seconds
30	Seconds

* Only available when time in seconds specified in any Timer function is zero or divisible by 60.

The Timer's maximum elapsed time in any format is equivalent to 99 hours, 59 minutes & 59 seconds.

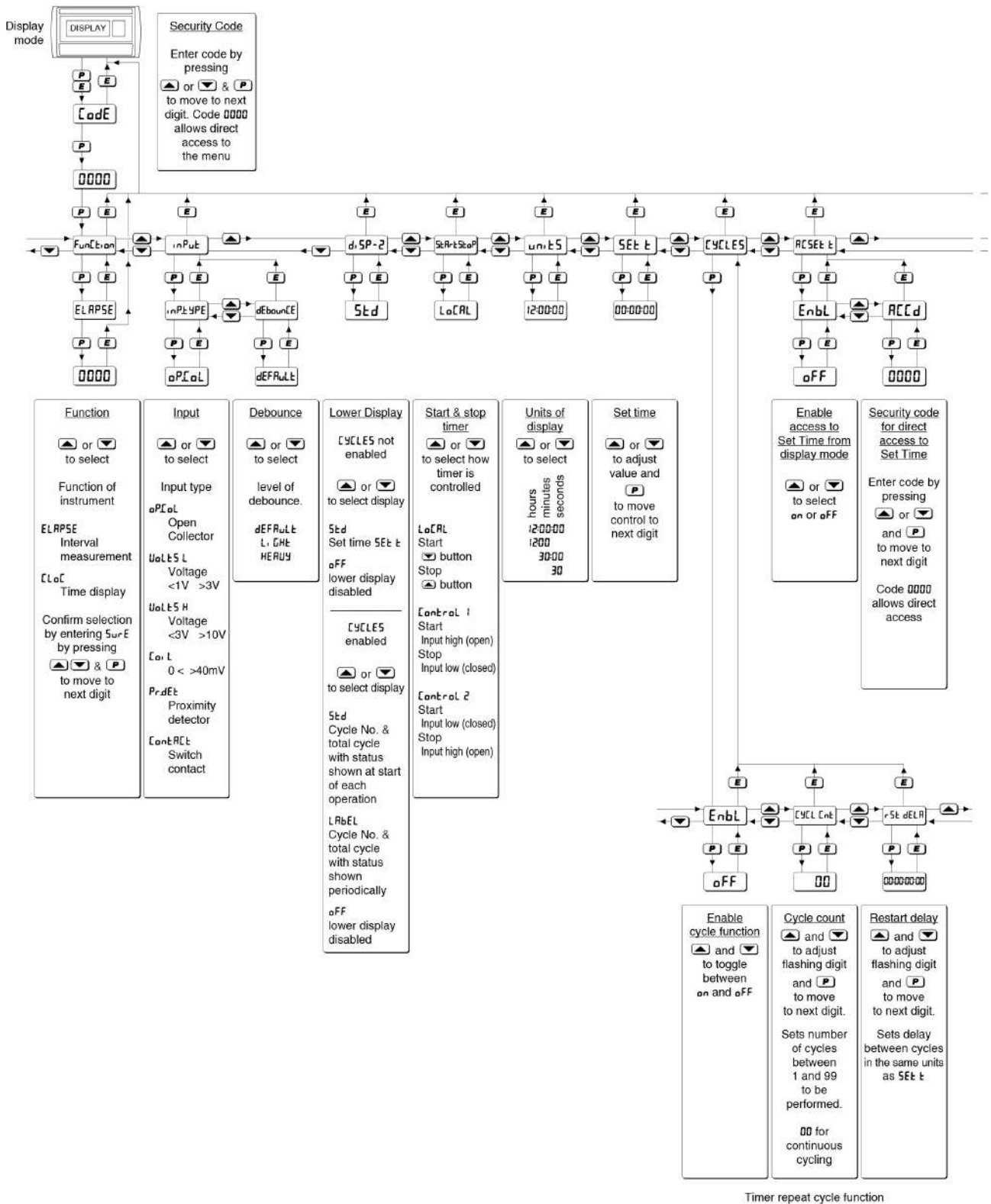
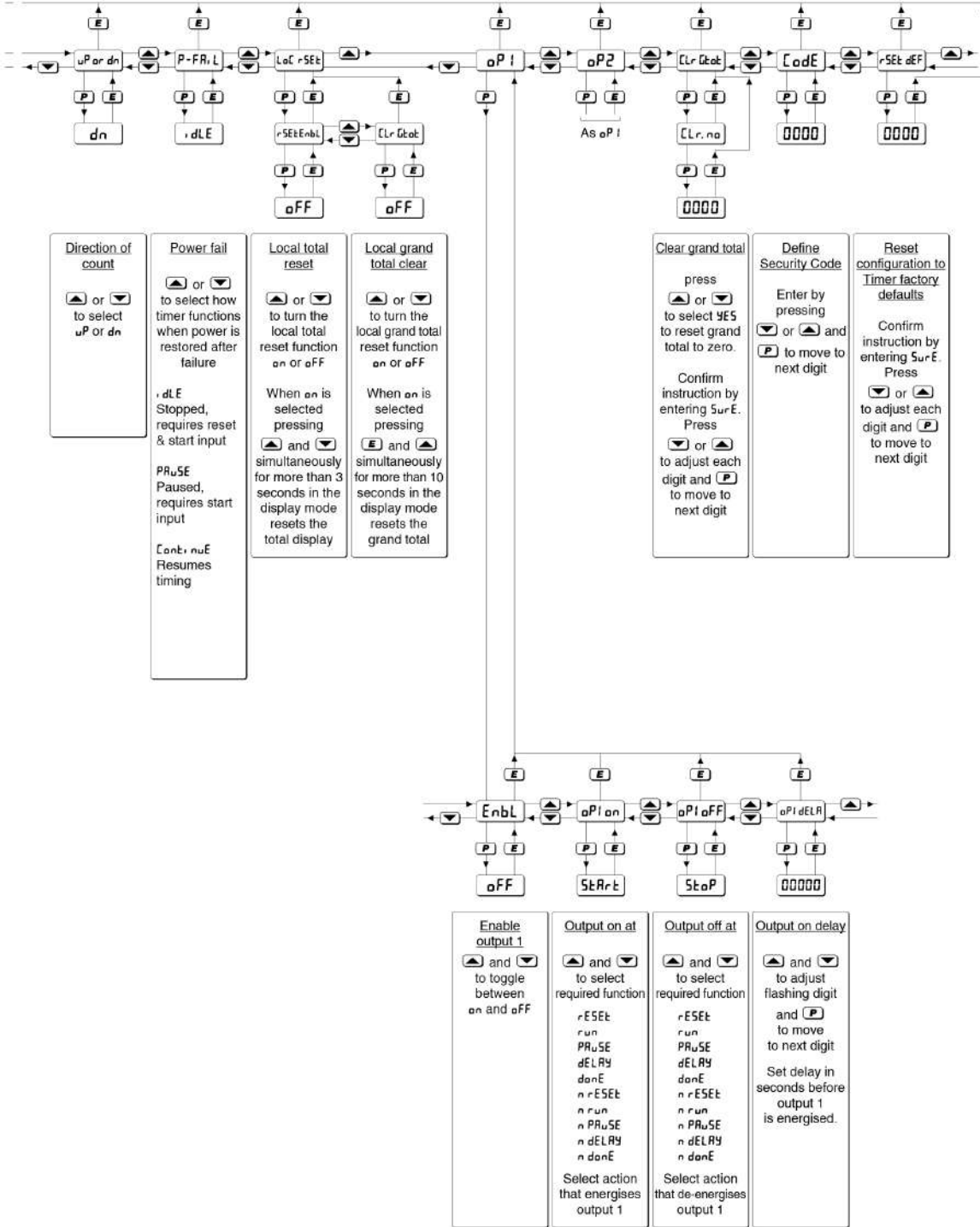

Fig 17 Timer Configuration menu

Only included when optional Control Outputs are fitted



Output 1 configuration

6.5.10 Set time: 5EŁ Ł

This is the Timer's setpoint. When controlling an external event via the optional control outputs the BA377E-SS will time-down from the set time to zero or time-up from zero to the set time.

To check or change the set time, select 5EŁ Ł from the configuration menu and press **P** which will reveal the existing setting with the most significant digit flashing. The flashing digit may be adjusted by pressing the **▲** or **▼** button followed by the **P** button to transfer control to the next digit. When set as required, enter the selection and return to the 5EŁ Ł prompt in the configuration menu by operating the **E** button.

Note: If 5EŁ Ł is zero the Timer will not function when an external start input is received or the **▼** button is operated.

6.5.11 Repeat timing cycle: ŁYŁŁE5

This powerful function enables the BA377E-SS timing cycle to be repeated up to 99 times or continuously with a configurable delay between cycles of up to 99 hours, 59 minutes & 59 seconds.

To check or adjust the repeat timing cycle, select ŁYŁŁE5 from the configuration menu and press **P** which will enter a sub-menu containing three sub-functions, EŁbŁ, ŁYŁŁ ŁŁŁ and Ł5Ł dELŁ which are described in the following sections.

6.5.12 Cycle function enable: EŁbŁ

This sub-function allows the repeat timing cycle to be enabled or disabled without altering any of the repeat timing cycle parameters. To check or change the function select EŁbŁ from the repeat timing cycle sub-menu and press **P** which will reveal if the repeat cycle function is ON or OFF. The setting can be changed by pressing the **▼** or **▲** button followed by the **E** button to return to the repeat timing cycle sub-menu.

6.5.13 Cycle count: ŁYŁŁ ŁŁŁ

This sub-function defines the number of times that the timer cycle is repeated. It may be set to any number between 1 and 99, or to 00 for continuous repetition.

To check or change the function select ŁYŁŁ ŁŁŁ from the repeat timing cycle sub-menu and press **P** which will reveal two digits with the most significant flashing. The flashing digit may be adjusted by pressing the **▲** or **▼** button followed by the **P** button to transfer control to the next digit. When set as required, enter the selection and return to the ŁYŁŁ ŁŁŁ prompt in the sub-menu by operating the **E** button.

6.5.14 Restart delay: Ł5Ł dELŁ

This sub-function defines the time delay between repeat timing periods. It is shown in the format selected in the units function and may be set to any time between zero and the maximum time allowed in the selected format.

Time format selected in	Maximum delay
ŁŁŁ Ł5	
12:00:00	99:59:59
12:00	99:59
30:00	5999:59
30	359999

To check or change the reset delay time select Ł5Ł dELŁ from the repeat timing cycle sub-menu and press **P** which will reveal the delay time in the selected format with the most significant digit flashing. The flashing digit may be adjusted by pressing the **▲** or **▼** button followed by the **P** button to transfer control to the next digit. When set as required, enter the selection and return to the Ł5Ł dELŁ prompt in the sub-menu by operating the **E** button.

Can also be adjusted from the Timer display mode, see 6.5.15

6.5.15 Adjusting the set time 5EŁ Ł and restart delay Ł5Ł dELŁ from the display mode: RŁ5EŁ Ł

When this function is enabled the Timer's set time 5EŁ Ł and restart delay Ł5Ł dELŁ can be adjusted from the display mode by simultaneously operating the **P** and **▲** push buttons. Thus allowing an operator to adjust these parameters without having access to the instrument's configuration menu. The function contains two sub-functions, EŁbŁ which activates the function and RŁŁŁ which defines a separate code for access to 5EŁ Ł with the Timer in the display mode.

To check or change the function, select RŁ5EŁ Ł in the configuration menu and press **P** which will reveal the EŁbŁ prompt, pressing **P** again will show if the function is ON or OFF. If adjustment of the set time from the display mode is not required press the **▲** or **▼** button to select OFF and then press **E** Ł twice to return to the configuration menu. If the function is required, select ON and press **E** to return to the EŁbŁ prompt from which RŁŁŁ, which allows a separate access code to be entered, can be selected by pressing the **▲** or **▼** button.

Access to 5EŁ Ł and Ł5Ł dELŁ from the display mode may be protected by a four digit alphanumeric security code which must be entered to gain access. Default security code 0000 allows unrestricted access. With RŁŁŁ displayed, press **P** to enter a

new access code. The Timer will display 0000 with one digit flashing. The flashing digit may be adjusted using the ▲ or ▼ push button, when set as required operating the [P] button will transfer control to the next digit. When all the digits have been entered press [E] twice to return to the READY prompt in the configuration menu. The revised access code will be activated when the BA377E-SS is returned to the display mode.

Please contact BEKA associates sales department if the access code is lost.

6.5.16 Direction of count: UP or dn

The Timer may be configured to *time-up* from zero to the set time 5E t while displaying elapsed time, or to *time-down* from the set time 5E t to zero while displaying the remaining time.

When the repeat timing cycle function [CYCLES] is enabled, it is recommended that a down count is selected so that the progress of the timer can be observed with a known completion time i.e zero. If set as an up counter, elapsed will be displayed, but 5E t at which the Timer will stop is not shown.

To check the direction of count, select UP or dn from the configuration menu and press [P] which will reveal the existing setting which can be changed by pressing the ▲ or ▼ button followed by the [E] button to enter the selection and return to the configuration menu.

6.5.17 Power Fail: P-FAIL

Defines how the Timer powers-up and functions when power is restored after a power supply interruption. Three options are available, dLE, PRUSE and Count, nUE.

dLE The Timer is stopped in the state it achieves when it has timed-up to 5E t or timed-down to 0000, with the elapsed or remaining time when power was lost shown on the upper display. The Timer must be reset before it can be restarted. If the repeat timing cycle is in use the number of cycles completed will be lost when the Timer is reset.

PRUSE The Timer is stopped in the state it achieves following receipt of a stop input to pause timing. The elapsed or remaining time when power was lost is shown on the upper display. Timing resumes when a start instruction is received. If a start input exists when power is restored timing will start immediately.

Count, nUE When power is restored the Timer will continue from where it stopped without any manual intervention. To check or change the function, select P-FAIL from the configuration menu and press [P] which will reveal the existing setting which can be changed by pressing the ▲ or ▼ button followed by the [E] button to enter the selection and return to the configuration menu.

6.5.18 Local reset: Local r5E t

The Local reset function contains two separate sub-functions r5E t.EnbL and CLR Gt o t which when enabled allow the Timer and the grand total to be reset via the instrument's front panel push buttons while the Timer is in the display mode.

6.5.19 Local total reset: r5E t.EnbL

r5E t.EnbL is a sub-function in the Local r5E t function which when activated allows an operator to reset the Timer from the display mode by operating the ▲ and ▼ push buttons simultaneously for more than three seconds.

To check or change the local total reset select Local r5E t in the configuration menu and press [P] which will reveal the Local r5E t prompt, press [P] again to show if the local total reset is on or off. If set as required operate the [E] button twice to return to the configuration menu, or the ▲ or ▼ button to change the setting followed by the [E] button twice to enter the change and return to the Local r5E t prompt in the configuration menu.

Note:

The Timer may also be reset remotely by connecting terminals RS1 and RS2 together for more than one second. See section 3.1.8 or 3.2.8

6.5.20 Local grand total reset: CLR Gt o t

The grand total is the total run-time of the Timer that may be viewed by operating the [E] and ▲ push buttons simultaneously in the display mode. When activated CLR Gt o t allows an operator to reset the grand total display to zero from the display mode by operating the [E] and ▲ push buttons simultaneously for more than ten seconds.

CLR Gt o t is a sub-function in the Local r5E t menu. To check or change the setting select Local r5E t in the configuration menu and press [P] which will reveal r5E t.EnbL. Using the ▼ or ▲ button select CLR Gt o t and press [P] which will show if local grand total reset is on or off. If set as required operate the [E] button twice to return to the configuration menu, or the ▼ or ▲ button to change the setting followed by the [E] button twice to enter the change and return to the Local r5E t prompt in the configuration menu.

6.5.21 Control output 1 (optional): *oP I*

Control output 1 is an optional factory fitted, galvanically isolated solid state switch contact which can be configured to turn *on* and *off* when the Timer enters a specified states. When control output 1 is *on* the '1' annunciator on the Timer display is activated.

The function contains four sub-functions, *EnbL*, *oP I on*, *oP I oFF* and *oP I dELR*. To gain access to the sub-menu select *oP I* in the configuration menu and press **P** which will show the *EnbL* prompt from which the other sub-functions can be accessed using the **▼** or **▲** button.

Control output 1 may be configured to turn *on* when the Timer enters a selected Timer state and to turn *off* when the Timer enters another specified Timer state. e.g. if *run* is selected in the *oP I on* sub-function and *donE* is selected the *oP I oFF* function. Control output 1 will turn *on* when the Timer enters the *run* state and will stay *on* until the Timer enters the *donE* state. Alternatively, the control output phase may be reversed by selecting the *n* states such as *n rESEt*.

If control output 1 is required to be *on* in only one Timer state, this can be achieved with the following configuration.

oP I on state required e.g. *run*
oP I oFF *n* state required e.g. *n run*

In this example when the Timer enters the *run* state control output 1 turns *on*. When the Timer moves from the *run* to any other state, control output 1 turns *off*.

The Timer configuration example in section 7.2 of this manual illustrate the use of the control outputs. Further examples can be found in Application Guide AG374 which is available on the BEKA website.

6.5.22 Control output 1 enable: *EnbL*

This function allows control output 1 to be enabled or disabled without altering any other control output parameters. To check or change the function select *EnbL* from the control output 1 sub-menu and press **P** to reveal if control output 1 is *on* or *oFF*. The setting can be changed by pressing the **▼** or **▲** button followed by the **E** button to return to the control output 1 sub-menu.

6.5.23 Control output 1 on at: *oP I on*

Control output 1 may be configured to turn *on* when the Timer enters any one of the five Timer states. Alternatively, the control output 1 phase may be reversed, by selecting an *n* state which will cause the control output to turn *on* when the Timer enters any other than the specified Timer state. Timer states are shown in Fig 16.

To define when control output 1 turns *on* select *oP I on* from the sub-menu and press **P** to show the existing setting. Pressing the **▼** or **▲** button will scroll through the options:

Display	Control output 1 turns on when Timer enters selected state
<i>rESEt</i>	Reset state
<i>run</i>	Running state
<i>PRuSEd</i>	Paused state
<i>dELAY</i>	Restart delay state
<i>donE</i>	Complete state
Control output 1 turns on when Timer enters any other than the selected state	
<i>n rESEt</i>	Reset state
<i>n run</i>	Running state
<i>n PRuSEd</i>	Paused state
<i>n dELAY</i>	Restart delay state
<i>n donE</i>	Complete state

When the required setting has been selected press **E** to enter the selection and return to the sub-menu.

6.5.24 Control output 1 off at: $\alpha P I \alpha FF$

Control output 1 may be configured to turn *off* when the Timer enters any one of the five Timer states. Alternatively, the phase of control output 1 may be reversed, by selecting an *n* state which will cause the control output to turn *off* when the Timer enters any other than the specified Timer state. Timer states are shown in Fig 16.

To define when control output 1 turns *off* select $\alpha P I \alpha FF$ from the sub-menu and press P to show the existing setting. Pressing the \blacktriangledown or \blacktriangle button will scroll through the options:

Display	Control output 1 turns off when Timer enters selected state
$r ESEt$	Reset state
$r un$	Running state
$PRuSEd$	Paused state
$dELAY$	Restart delay state
$donE$	Complete state
Control output 1 turns off when Timer enters any other than the selected state	
$n r ESEt$	Reset state
$n r un$	Running state
$n PRuSEd$	Paused state
$n dELAY$	Restart delay state
$n donE$	Complete state

When the required setting has been selected press E to enter the selection and return to the control output 1 sub-menu.

6.5.25 Control output 1 on delay time: $\alpha P I dELR$

Control output 1 may be delayed from turning *on* (output closed) for a fixed time following the selected condition occurring. e.g. when the Timer enters the *Run* state. This delay can be adjusted in 1 second increments up to 32,400 seconds, which is 9 hours. If a delay is not required zero should be entered. To adjust the delay select $\alpha P I dELR$ from the control output 1 sub-menu and press P which will reveal the existing delay time with one digit flashing. The flashing digit can be adjusted using the \blacktriangledown or \blacktriangle button and the P button to move to the next digit. When the required delay has been entered, press E to return to the control output 1 sub-menu.

The timer configuration example in section 7.2 of this manual illustrates how to configure the optional control outputs.

6.5.26 Control output 2 (optional): $\alpha P 2$

Control output 2 is an optional, galvanically isolated solid state switch contact which can be independently configured to turn *on* and *off* when the Timer is any of its five states. Its functions and configuration are identical to control output 1 described in sections 6.5.21 to 6.5.25

The control output status is shown by the 2 control output display annunciator.

6.5.27 Reset grand total from within the configuration menu: CLR CLt

The grand total is the total run-time of the Timer that may be viewed by operating the E and \blacktriangle push buttons simultaneously in the display mode.

The grand total can be reset to zero from within the configuration menu using this CLR CLt function, or from the display mode if CLR CLt is activated in the local grand total clear function - see 6.5.20

To zero the Timer grand total from within the configuration menu select CLR CLt and press P which will cause the instrument to display CLR.no with *no* flashing. Press the \blacktriangledown or \blacktriangle push button until CLR.9E5 is displayed and then press P which will result in a 0000 prompt being displayed with the first digit flashing. This is a request for the instruction to be confirmed by entering $5urE$ using the \blacktriangledown and \blacktriangle buttons to adjust the flashing digit and the P button to move control to the next digit. Pressing E will then reset the grand total to zero and return the Timer to the configuration menu.

Note: Once reset, the grand total can not be recovered.

6.5.28 Security code: Code

Access to the instrument configuration menu may be protected by a four digit alphanumeric security code which must be entered to gain access. New instruments are configured with the default security code 0000 which allows unrestricted access to all configuration functions.

To enter a new security code select CodE from the configuration menu and press P which will cause the Timer to display 0000 with one digit flashing. The flashing digit may be adjusted using the \blacktriangle and \blacktriangledown push button, when set as required operating the P button will transfer control to the next digit. When the new security code has been entered press E to return to the CodE prompt. The revised security code will be activated when the Timer is returned to the display mode.

Please contact BEKA associates sales department if the security code is lost.

6.5.29 Reset configuration to Timer factory defaults: r5Et dEF

When the BA377E-SS is configured as a Timer this function resets the instrument to the Timer factory defaults shown in sections 6.5

To reset the configuration select *r5Et dEF* from the configuration menu and press **[P]**. The BA377E-SS will display 0000 with the first digit flashing which is a request to confirm the instruction by entering 5urE. Using the **[▲]** or **[▼]** button set the first flashing digit to 5 and press **[P]** to transfer control to the second digit which should be set to u. When 5urE has been entered pressing the **[E]** button will reset all the configuration functions and return the instrument to the display mode.

Note:

r5Et dEF does not reset the grand total to zero.

7. TIMER APPLICATION EXAMPLES

This section illustrates two common applications for the BA377E-SS when configured as a Timer.

7.1 Measuring the time that a contact is closed.

In this example a BA377E-SS is required to display the time that a hazardous area contact is closed. The display is required in hours and minutes within the hazardous area and is to be reset to zero by a push button located in the same hazardous area, not by the instrument front panel push buttons. The operator is required to zero the grand total by operating the **[E]** and **[▲]** buttons simultaneously. No security codes are required to protect access to the configuration menu or to the grand total reset. When power is restored after a supply interruption the Timer is to resume normal operation without manual intervention.

Figure 18 shows the wiring for the BA377E-SS when powered by a single channel Zener barrier.

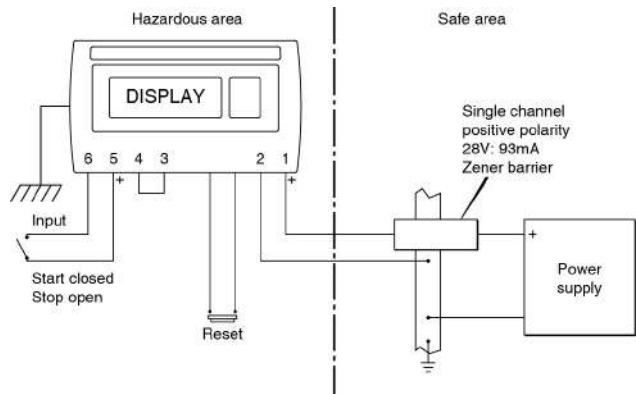

Fig 18 Wiring for displaying time a contact is closed

The required instrument configurations for this example are shown below.

Function	Display	Setting
Access code	[adE	0000
Function	Fun[E, on	ELAPSE
Input	, nPut	[ontAR[E
Terminals 3 & 4 linked to energise input		
Debounce	dEboun[E	dEFRAuLt
Display 2	d, SP-2	oFF
Start stop	StArStoP	[ontrol 2
Units	un, tS	12:00
Set time	SEt t	9999:99:99
Direction of count	uP or dn	uP
Power fail	P-FR, L	[ont, nuE
Local reset	La[r5Et	
Local total reset	rESE Enbl	oFF
Local grand total reset	[Lr Gtob	on

7.2 Controlling an IS solenoid valve

The BA377E-SS Timer is required to open an intrinsically safe solenoid valve for 5 minutes when an external contact is closed. 55 minutes after the valve is closed it is to be opened again for another 5 minute period. This process is to be repeated 10 times after which the Timer is to automatically reset so that is ready to start the next 10 cycles when the external contact is closed.

In this example which is shown in Fig 19, control output 2 has been wired to the timer reset terminals and configured with a five seconds control output delay after the solenoid valve has closed for the tenth time. Therefore five seconds after the tenth cycle has been completed the system automatically resets and is ready for the next timing cycle to be initiated.

The lower display is required to show timer status at the start of each period.

After a power interruption the timer is required to resume operation from the point at which it stopped when the start button is operated.

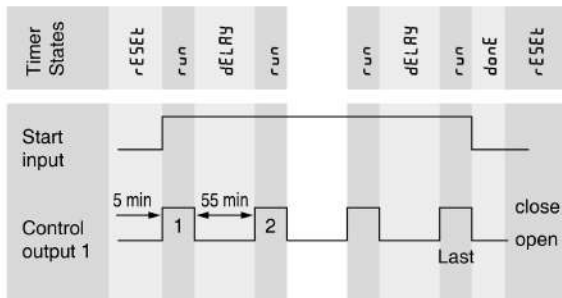
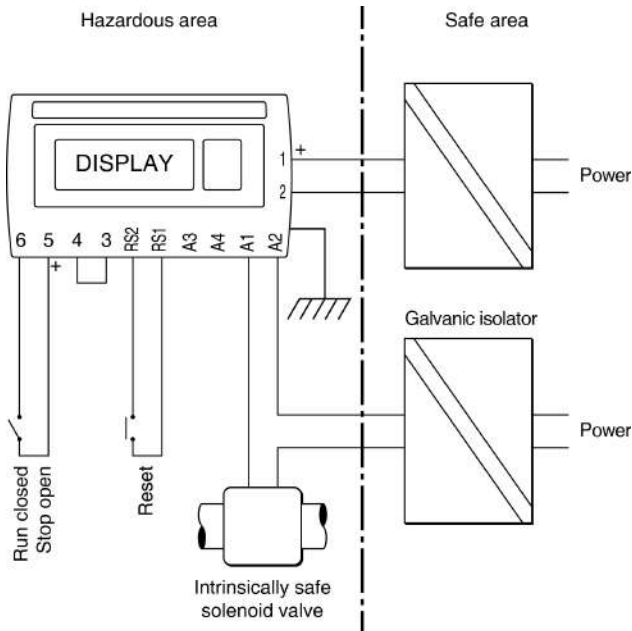

Fig 19 Control of valve in a hazardous area

The required instrument configuration for this example are shown below.



Function Access code	Display Code	Setting 0000
Function	Function	ELAPSE
Input	Input	
Input	INPUT	CONTACT
Terminals 3 & 4 linked to energise input		
Debounce	DEBOUNCE	DEFAULT
Display 2	di SP-2	5td
Start stop	STARTSTOP	CONTROL 2
Units	units	12:00
Set time	SET t	00:05
Timer repeat cycle	CYCLES	
Cycle function enable	ENBL	on
Cycle count	CYCL CNT	10
Reset delay	RESET DELA	00:55
Access set time from display mode.	RESET - t	OFF
Direction of count	UP or DN	UP
Power failure	P-FAIL	PAUSE
Local reset	LOC RESET	
Local total reset	RESET.ENBL	on
Local grand total reset	GRSTAT	OFF
Output 1	OP 1	
Enable control output 1	ENBL	on
Control output 1 on at	OP 1 ON	run
Control output 1 off at	OP 1 OFF	run
Control output 1 delay	OP 1 DELA	00000
Output 2	OP 2	
Enable control output 2	ENBL	on
Control output 2 on at	OP 2 ON	done
Control output 2 off at	OP 2 OFF	RESET
Control output 2 delay	OP 2 DELA	00005

In this example local total reset RESET.ENBL is on. This enables the Timer to be reset when power is first connected by operating the and down button simultaneously for more than 3 seconds.

8. MAINTENANCE when configured as a Timer

8.1 Fault finding during commissioning

If a BA377E-SS fails to function as a Timer during commissioning the following procedure should be followed:



Symptom	Cause	Check:
No display	No power supply, or incorrect wiring. Note: Terminals 2, 6 & RS2 are interconnected within the instrument.	That there is between 10 and 28V on terminals 1 & 2 with terminal 1 positive.
Instrument configuration menu does not correspond with Timer section of this manual.	BA377E-SS may be configured as a clock.	That <code>Function</code> in configuration menu is set to <code>ELAPSE</code> not to <code>ELC</code> .
Timer will not start.	Timer not reset	Reset timer via external contact or by operating  and  buttons simultaneously if the local total reset <code>RESET Enbl</code> has been activated.
	Set time <code>SEt t</code> has not been entered.	Enter a value for <code>SEt t</code> other than zero.
Timer will not respond to external input.	Input incorrectly configured, or sensor incorrectly connected.	Input configuration and input energising link is correctly fitted for selected sensor.
Control output(s) do not function.	Control outputs have not been enabled.	Enable Control Output(s) in the configuration menu.
Unable to enter configuration menu.	Incorrect security code	That the correct security code is being used. Contact BEKA if code is lost.

8.2 Fault finding after commissioning

ENSURE PLANT SAFETY BEFORE STARTING MAINTENANCE

Live maintenance is permitted on intrinsically safe equipment installed in a hazardous area, but only certified test equipment should be used unless a gas clearance certificate is available.

If a BA377E-SS fails after it has been functioning correctly, the following table may help to identify the cause of the failure.

Symptom	Cause	Check:
No display	No power supply	That there is between 10 and 28V on terminals 1 & 2 with terminal 1 positive.
Timer will not start.	Timer not reset	Reset timer via external contact or by operating  and  buttons simultaneously if local total reset <code>RESET Enbl</code> has been activated.
	Reset terminals RS1 & RS2 are linked which will inhibit Timer.	Remove link.
Control output(s) do not function.	Control Outputs have not been enabled.	Enable Control Output(s) in the configuration menu.
Unable to enter configuration menu.	Incorrect security code	That the correct security code is being used. Contact BEKA if code is lost.

If this procedure does not reveal the cause of the fault, it is recommended that the instrument is replaced.

Note:

If configuration changes are made to `Input`, `SetPoint`, `Display`, `up` or `dn`, `AP1` or `AP2` functions the Timer will be forced into a fail safe `HL` condition. This stops the Timer in the state it achieves when it has timed-up to `SEt t` or timed-down to `0000`. The Timer must be reset before it can be restarted.

8.3 Servicing

We recommend that faulty BA377E-SS Timers are returned to BEKA associates or to our local agent for repair. It is helpful if a brief description of the fault symptoms is provided.

8.4 Routine maintenance

The mechanical and electrical condition of the instrument should be regularly checked. Inspection frequency should be chosen to suit the environmental conditions.

8.5 Guarantee

Instruments which fail within the guarantee period should be returned to BEKA associates or our local agent. It is helpful if a brief description of the fault symptoms is provided.

8.6 Customer comments

BEKA is always pleased to receive comments from customers about our products and services. All communications are acknowledged and whenever possible, suggestions are implemented.

9. OPERATION AS A CLOCK

When configured as a clock the BA377E-SS can display local time in a variety of twelve or twenty four hour formats. The displayed time can be adjusted via the front panel push buttons which may be protected by a user definable four digit security code to prevent unauthorised or accidental adjustment.

The clock may be synchronised to an external time standard via the instrument's reset terminals. When these two terminals are connected together by an external switch contact, the clock display will be reset to a preconfigured time and will resume running from this time when the contacts are opened.

When fitted with the optional galvanically isolated control outputs the clock can be configured to turn each solid state output *on* and *off* twice during each twenty four hour period.

Fig 20 shows a simplified block diagram of the BA377E-SS configured as a clock.

The instrument can be supplied with the following factory fitted accessories:

Backlight Internally powered

Dual isolated control outputs

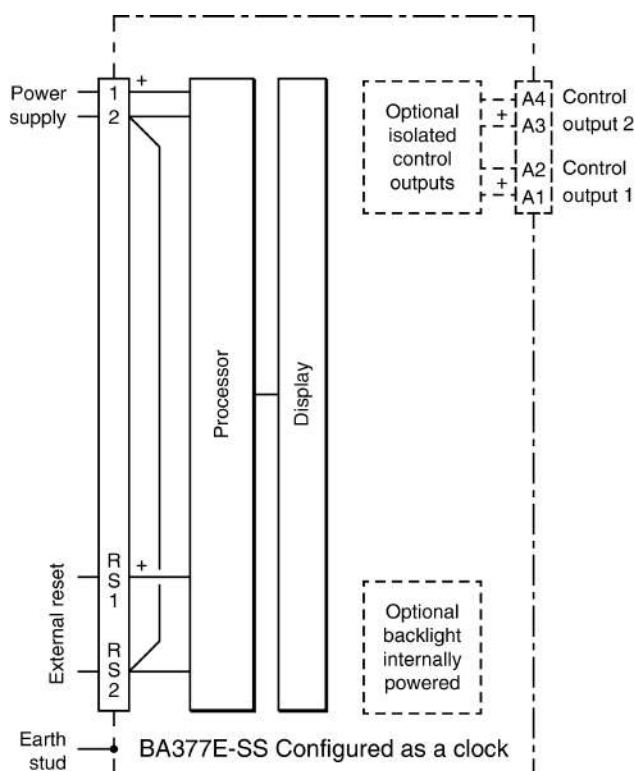

Fig 20 Block diagram of BA377E-SS configured as a clock.

9.1 Initialisation and loss of power

Each time power is applied to a BA377E-SS initialisation is performed. After a short delay the following display sequence occurs:

All segments of the display are activated

Instrument starts functioning using the configuration stored in the instrument's permanent memory.

Following initialisation, the instrument will display a flashing display which is a request for the local time to be entered. The clock will not start to function until a display time has been entered, or the remote reset contacts are closed and opened to synchronise the clock to a preconfigured time.

If during normal operation the power supply is interrupted for more than 30ms, the display will return to the flashing condition and the display time will have to be re-entered. Longer interruptions may be tolerated by powering the Clock from a lightly loaded galvanic isolator or via a Zener barrier from an instrument supply with large output capacitance.

9.2 Controls when configured as a clock

The BA377E-SS clock is configured and adjusted via four front panel push buttons. In the display mode i.e. when the instrument is displaying time, the push button functions are:

- * **P** + **▼** Shows in succession, firmware version number, instrument function [L o E] and output accessories that are fitted:
-R Dual Control Outputs
- P** + **E** Access to configuration menu

Note: When optional control outputs are fitted, the BA377E-SS clock may be configured to provide direct access to the control output *on* and *off* times from the display mode when the **P** and **▲** push buttons are operated simultaneously. - see section 9.4.13

9.3 Displays when configured as a clock

The BA377E-SS clock has a single digital display plus annunciators.

- Time display** Shows time in selected 12 or 24 hour format.
- Reset annunciator** Activated while clock is being synchronised and external reset contacts are closed.
- Control output annunciators** Show status of both optional control output.

9.4 Configuration as a clock

The BA377E-SS is configured and calibrated via four front panel push buttons. All the configuration functions are contained in an easy to use intuitive menu that is shown diagrammatically in Fig 21.

Each menu function is summarised in section 9.4.2 and each includes a reference to more detailed information in this manual.

All new BA377E-SS instruments are supplied configured as requested at the time of ordering. If configuration is not requested, the BA377E-SS will be supplied with default Timer configuration as shown in section 6.5.





If a BA377E-SS Clock is requested without detailed configuration information, the instrument will be supplied with default Clock configuration as shown below, but can easily be re-configured on-site.







Default Clock Configuration

Function	Display	Default
Access code	Code	0000
Function	Function	CLC
Display	display	12:00
Synchronise time	Sync	R 12:00:00
Enable control output 1*	EnbL	oFF
Enable control output 2*	EnbL	oFF
Enable access alarm	ALSP	oFF
times from display mode.		
Access code for alarm	ALCd	0000
times from display mode.		



Note: * Control outputs are an option

9.4.1 Accessing configuration functions

Throughout this manual push buttons are shown as , ,  and  and legends displayed by the Clock are shown in a seven segment font as they appear on the instrument e.g. d, SPly and Code.

Access to the configuration menu is obtained by operating the  and  push buttons simultaneously. If the instrument is not protected by an access security code the first parameter Function will be displayed. If a security code other than the default code 0000 has already been entered, the instrument will display Code. Press  to clear this prompt and enter the security code for the instrument using the  or  push button to adjust the flashing digit, and the  push button to transfer control to the next digit. If the correct code has been entered pressing  will cause the first parameter Function to be displayed. If an incorrect code is entered, or a push button is not operated within ten seconds, the instrument will automatically return to the display mode.

All configuration functions and prompts are shown on the upper eight digit display.

Once within the main configuration menu the required function can be selected by scrolling through the menu using the  and  push buttons. The Clock configuration menu is shown diagrammatically in Fig 21.

When returning to the display mode following reconfiguration, the Clock will display dRtR followed by SAVE while the new information is stored in permanent memory.

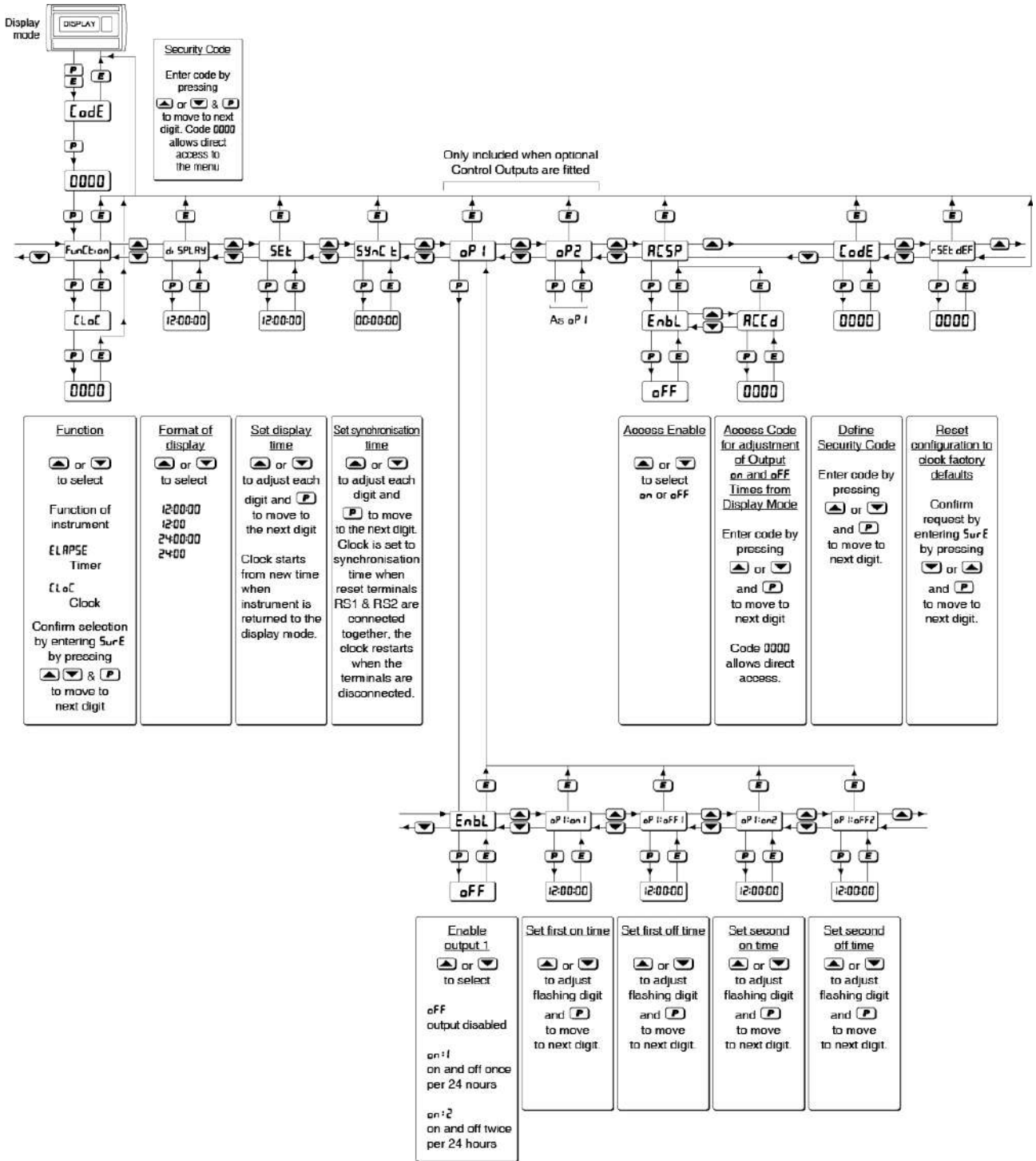

Fig 21 Clock Configuration menu

9.4.2 Summary of Clock configuration functions.

This section summarises all the Clock configuration functions. When read in conjunction with Fig 21 it provides a quick aid for configuring the Clock. If more detail is required, each section of this summary contains a reference to a full description of the function.

Display	Summary of function	Display	Summary of function														
FunCt, on	<p>Instrument function Defines the function of the instrument. May be set to:</p> <table border="0"> <tr> <td>ELRP5E</td> <td>Timer</td> </tr> <tr> <td>ELoC</td> <td>Clock</td> </tr> </table> <p>All the entries in this Clock configuration summary assume that the BA377E-SS is configured as a Clock by selecting [LoC]. See section 9.4.3</p>	ELRP5E	Timer	ELoC	Clock	oP 1	<p>Control output 1 (Optional) Control output 1 can turn <i>on</i> (output closed) and <i>off</i> (output open) twice in each twenty-four hour period. This function contains five sub-function:</p> <table border="0"> <tr> <td>EnbL</td> <td>Enables output 1 and defines if it turns on and off once or twice in each 24 hours.</td> </tr> <tr> <td>oP 1: on 1</td> <td>Time when oP 1 turns <i>on</i> 1st time</td> </tr> <tr> <td>oP 1: oFF 1</td> <td>Time when oP 1 turns <i>off</i> 1st time</td> </tr> <tr> <td>oP 1: on 2</td> <td>Time when oP 1 turns <i>on</i> 2nd time</td> </tr> <tr> <td>oP 1: oFF 2</td> <td>Time when oP 1 turns <i>off</i> 2nd time</td> </tr> </table> <p>See section 9.4.7 to 9.4.9</p>	EnbL	Enables output 1 and defines if it turns on and off once or twice in each 24 hours.	oP 1: on 1	Time when oP 1 turns <i>on</i> 1 st time	oP 1: oFF 1	Time when oP 1 turns <i>off</i> 1 st time	oP 1: on 2	Time when oP 1 turns <i>on</i> 2 nd time	oP 1: oFF 2	Time when oP 1 turns <i>off</i> 2 nd time
ELRP5E	Timer																
ELoC	Clock																
EnbL	Enables output 1 and defines if it turns on and off once or twice in each 24 hours.																
oP 1: on 1	Time when oP 1 turns <i>on</i> 1 st time																
oP 1: oFF 1	Time when oP 1 turns <i>off</i> 1 st time																
oP 1: on 2	Time when oP 1 turns <i>on</i> 2 nd time																
oP 1: oFF 2	Time when oP 1 turns <i>off</i> 2 nd time																
d, SP LAY	<p>Display format Defines the clock display format, four alternatives are available. Select:</p> <table border="0"> <tr> <td>12:00:00</td> <td>Twelve hours with seconds</td> </tr> <tr> <td>12:00</td> <td>Twelve hours without seconds</td> </tr> <tr> <td>24:00:00</td> <td>Twenty four hours with seconds</td> </tr> <tr> <td>24:00</td> <td>Twenty four hours without seconds</td> </tr> </table> <p>See section 9.4.4</p>	12:00:00	Twelve hours with seconds	12:00	Twelve hours without seconds	24:00:00	Twenty four hours with seconds	24:00	Twenty four hours without seconds	oP2	<p>Control output 2 (Optional) As control output 1 described above. See section 9.4.10 to 9.4.12</p>						
12:00:00	Twelve hours with seconds																
12:00	Twelve hours without seconds																
24:00:00	Twenty four hours with seconds																
24:00	Twenty four hours without seconds																
SEt	<p>Set clock display time Enables the clock displayed time to be adjusted, the clock resumes operation when the instrument is returned to the display mode. See section 9.4.5</p>	RESP	<p>Access control output alarm-times from display mode. Contains two sub-functions, EnbL which when activated allows the control output times to be adjusted from the display mode (when BA377E-SS is displaying time). The second sub-function REEd defines a four digit alphanumeric access code which may be used to protect access to the alarm-times from the display mode. Default code 0000 disables this security feature and allows unrestricted access. See section 9.4.13</p>														
SYnC t	<p>Synchronising time Defines the time to which the clock display is set when the reset terminals RS1 and RS2 are connected together. The Clock restarts from the synchronising time when terminals RS1 and RS2 are disconnected. See section 9.4.6</p>	Lo dE	<p>Security code Defines a four digit alphanumeric code that may be used to protect access to the Clock configuration menu. Default code 0000 disables this security function and allows unrestricted access to all configuration functions when the [D] and [E] buttons are operated simultaneously in the display mode. See section 9.4.14</p>														
		r5Et dEF	<p>Reset to factory defaults Resets the BA377E-SS to the clock factory default configuration shown in section 9.4 when 5rE5 is selected and confirmed by entering 5urE. See section 9.4.15</p>														

9.4.3 Instrument function: $F_{un}C_{lock}$

The BA377E-SS may be configured as a Timer or as a Clock. This section of the instruction manual describes the Clock configuration, for details of Timer configuration see section 6.5.

To reveal the existing function of the instrument select $F_{un}C_{lock}$ from the configuration menu and press \mathbb{P} . If C_{lock} is displayed, the instrument is already configured as a Clock therefore press \mathbb{E} to return to the $F_{un}C_{lock}$ prompt in the configuration menu. If $ELAPSE$ is displayed, press the \blacktriangle or \blacktriangledown button to change the setting to C_{lock} followed by the \mathbb{P} button which will result in a 0000 prompt being displayed with the first digit flashing. This is a request for the instruction to be confirmed by entering $5_{ur}E$ using the \blacktriangle or \blacktriangledown button to adjust the flashing digit and the \mathbb{P} button to move control to the next digit. When $5_{ur}E$ has been entered, pressing \mathbb{E} will change the instrument to a Clock and return the instrument to the display mode. To configure the Clock enter the configuration menu by pressing the \mathbb{P} and \mathbb{E} buttons simultaneously until $F_{un}C_{lock}$ is displayed.

9.4.4 Display format: d_{isplay}

The BA377E-SS Clock may be configured to display time in a 12 or 24 hour format with or without seconds. When a 12 hour format is selected, AM is denoted by an R prefix at the left hand side of the display, similarly a P is displayed to denote PM.

To check or change the display format of the clock, select d_{isplay} from the configuration menu and press \mathbb{P} which will reveal the existing setting which can be changed by pressing the \blacktriangle or \blacktriangledown button followed by the \mathbb{E} button to enter the selection and return to the configuration menu. The options available are shown below:

12:00:00	Twelve hour format with seconds
12:00	Twelve hour format without seconds
24:00:00	Twenty four hour format with seconds
24:00	Twenty four hour format without seconds

9.4.5 Set clock display time: $5E_{t}$

This function sets the time displayed by the Clock which must be entered each time the BA377E-SS Clock is powered. Until a set time is entered the Clock will display a flashing $00:00:00$ or $00:00$ for 24 hour formats, or $R 12:00:00$ or $R 12:00$ for 12 hour formats.

To adjust the clock set time, select $5E_{t}$ from the configuration menu and press \mathbb{P} that will show $00:00:00$ or the existing set time with the hours flashing. When setting the clock display time seconds are always shown.

Using the \blacktriangle or \blacktriangledown button adjust the flashing hours and then press \mathbb{P} to transfer control to the minutes display, pressing \mathbb{P} again will transfer control to the seconds display. When the clock display time has been adjusted press \mathbb{E} to start the Clock and return to the $5E_{t}$ prompt in the configuration menu.

9.4.6 Enter synchronising time: $5_{yn}C_{t}$

When the external reset terminals RS1 and RS2 are connected together the clock is stopped and the displayed time is set to the synchronising time. When the connection between the reset terminals is removed, the clock restarts from the synchronising time. This function enables the BA377E-SS clock to be synchronised with a master clock.

To enter the synchronising time, select $5_{yn}C_{t}$ from the configuration menu and press \mathbb{P} which will reveal the existing synchronising time with the hours flashing. Using the \blacktriangle or \blacktriangledown button adjust the hours and then press \mathbb{P} to transfer control to the minutes display, pressing \mathbb{P} again will transfer control to the seconds display. When the synchronising time has been set as required, press \mathbb{E} to return to the configuration menu.

9.4.7 Control output 1 (Optional): oP_{1}

Control output 1 is an optional factory fitted galvanically isolated solid state switch contact output which can be configured to turn *on* (output closed) and *off* (output open) twice in each twenty-four hour period. The control output status is shown by the 1 control output display annunciator.

Function oP_{1} contains a sub-menu with five sub-functions:

E_{nbl}	Number of times output 1 turns <i>on</i> & <i>off</i> in 24 hours.
$oP_{1}:o_{n}1$	First time oP_{1} turns <i>on</i> (closes)
$oP_{1}:o_{FF}1$	First time oP_{1} turns <i>off</i> (opens)
$oP_{1}:o_{n}2$	Second time oP_{1} turns <i>on</i> (closes)
$oP_{1}:o_{FF}2$	Second time oP_{1} turns <i>off</i> (opens)

To check or change the function of Control output 1 select oP_{1} from the configuration menu and press \mathbb{P} which will reveal the first sub-function E_{nbl} .

9.4.8 Enable Control output 1: E_{nbL}

This is a sub-function in the Control output 1 function $\alpha P 1$ which allows output 1 to be enabled or disabled without changing any of the *on* or *off* times and also determines whether output 1 turns *on* and *off* once or twice in each twenty four hour period.

Select $\alpha P 1$ in the configuration menu and press \square which will result in the E_{nbL} prompt being displayed. Pressing \square again will enter the sub-function from which one of the three options may be selected using the \blacktriangle or \blacktriangledown button:

Display	Control output 1
αFF	Control output 1 disabled
$\alpha n : 1$	Turns <i>on</i> & <i>off</i> once per 24 hours
$\alpha n : 2$	Turns <i>on</i> & <i>off</i> twice per 24 hours

When the required option is displayed operating \square will enter the selection and return to the E_{nbL} prompt from which another sub-function may be selected if control output 1 has not been disabled.

9.4.9 On and off times: $\alpha P 1 : \alpha n 1$; $\alpha P 1 : \alpha FF 1$ $\alpha P 1 : \alpha n 2$; $\alpha P 1 : \alpha FF 2$

The control output will have one or two *on* and *off* times depending upon whether control output 1 has been configured to turn *on* and *off* once or twice in each 24 hour period. - see 9.4.8.

All of the times are adjusted in the same way. To adjust any of them select $\alpha P 1$ from the configuration menu and press \square which will result in the E_{nbL} prompt being displayed. The \blacktriangle or \blacktriangledown button will scroll through the sub-functions. Only $\alpha P 1 : \alpha n 1$ and $\alpha P 1 : \alpha FF 1$ will be present if control output 1 has been configured to switch *on* and *off* once in a 24 hour period in the E_{nbL} sub-function.

Select the required sub-function

$\alpha P 1 : \alpha n 1$	Time $\alpha P 1$ turns <i>on</i> first time
$\alpha P 1 : \alpha FF 1$	Time $\alpha P 1$ turns <i>off</i> first time
$\alpha P 1 : \alpha n 2$	Time $\alpha P 1$ turns <i>on</i> second time
$\alpha P 1 : \alpha FF 2$	Time $\alpha P 1$ turns <i>off</i> second time

When selected, pressing \square will show the existing time with the hours flashing. Using the \blacktriangle or \blacktriangledown button adjust the hours and then press \square to transfer control to the minutes display, pressing \square again will transfer control to the seconds display. When the time has been set as required press \square to return to the sub-menu from which another *on* / *off* time may be selected for adjustment. When all the *on* / *off* times have been entered, return to the configuration menu by pressing the \square button twice.

9.4.10 Control output 2 (Optional): $\alpha P 2$

Control output 2 is an optional factory fitted output which can be configured to turn *on* (output closed) and *off* (output open) twice in each twenty-four hour period. The control output status is shown by the 2 control output display annunciator.

Function $\alpha P 2$ contains a sub-menu with five sub-functions:

E_{nbL}	Number of times output 2 turns <i>on</i> & <i>off</i> in 24 hours.
$\alpha P 2 : \alpha n 1$	First time when $\alpha P 2$ turns <i>on</i> (closes)
$\alpha P 2 : \alpha FF 1$	First time when $\alpha P 2$ turns <i>off</i> (opens)
$\alpha P 2 : \alpha n 2$	Second time when $\alpha P 2$ turns <i>on</i> (closes)
$\alpha P 2 : \alpha FF 2$	Second time when $\alpha P 2$ turns <i>off</i> (opens)

To check or change the function of Control output 2 select $\alpha P 2$ from the configuration menu and press \square which will reveal the first sub-function E_{nbL} .

9.4.11 Enable control output 2: E_{nbL}

This is a sub-function in the Control output 2 function $\alpha P 2$ which allows output 2 to be enabled or disabled without changing any of the *on* or *off* times and also determines whether output 2 turns *on* and *off* once or twice in each twenty four hour period. Select $\alpha P 2$ in the configuration menu and press \square which will result in the E_{nbL} prompt being displayed. Pressing \square again will enter the sub-function from which one of the three options may be selected using the \blacktriangle or \blacktriangledown button:

Display	Control output 2
αFF	Control output 2 disabled
$\alpha n : 1$	Turns <i>on</i> & <i>off</i> once per 24 hours
$\alpha n : 2$	Turns <i>on</i> & <i>off</i> twice per 24 hours

When the required option is displayed operating \square will enter the selection and return to the E_{nbL} prompt from which another sub-function may be selected if control output 2 has not been disabled.

9.4.12 On and off times: $\alpha P 2 : \alpha n 1$; $\alpha P 2 : \alpha FF 1$ $\alpha P 2 : \alpha n 2$; $\alpha P 2 : \alpha FF 2$

The control output will have one or two *on* and *off* times depending upon whether control output 2 has been configured to turn *on* and *off* once or twice in each 24 hour period. - see 9.4.11.

All of the times are adjusted in the same way. To adjust any of them select $\alpha P 2$ from the configuration menu and press \square which will result in the E_{nbL} prompt being displayed. The \blacktriangle or \blacktriangledown button will scroll through the sub-functions. Only $\alpha P 2 : \alpha n 1$ and $\alpha P 2 : \alpha FF 1$ will be present if control output 2 has been configured to switch *on* and *off* once in a 24 hour period in the E_{nbL} sub-function.

Select the required sub-function

oP2:on 1	Time oP2 turns <i>on</i> first time
oP2:off 1	Time oP2 turns <i>off</i> first time
oP2:on 2	Time oP2 turns <i>on</i> second time
oP2:off 2	Time oP2 turns <i>off</i> second time

When selected pressing **[P]** will show the existing time with the hours flashing. Using the **[▲]** or **[▼]** button adjust the hours and then press **[P]** to transfer control to the minutes display, pressing **[P]** again will transfer control to the seconds display. When the time has been set as required press **[E]** to return to the sub-menu from which another *on / off* time may be selected for adjustment. When all the *on / off* times have been entered, return to the configuration menu by pressing the **[E]** button twice.

9.4.13 Access control output *on* & *off* times from display mode: **R[5P]**

This function activates a separate menu that provides direct access to the control output's *on* and *off* times when the Clock is the display mode (displaying time). An operator may therefore adjust the *on* and *off* times without having access to the instrument configuration menu. Further protection is provided by a separate security code. When this function is enabled the *on* and *off* times of the two control outputs may be adjusted from the display mode by simultaneously operating the **[P]** and **[▲]** push buttons. The function contains two sub-functions, **E[nbL]** which activates the function and **R[Ed]** which defines a separate access code that may be used to prevent the *on* and *off* times being accidentally adjusted from the display mode.

To check or change the function, select **R[5P]** in the configuration menu and press **[P]** which will reveal the **E[nbL]** prompt, pressing **[P]** again will show if the function is *on* or *off*. If adjustment of the control output times from the display mode is not required press the **[▲]** or **[▼]** button to select *off* and then press **[E]** twice to return to the configuration menu. If the function is required, select *on* and press **[E]** to return to the **E[nbL]** prompt from which **R[Ed]**, which allows a separate access code to be entered, can be selected by pressing the **[▲]** or **[▼]** button.

Access to the control output times from the display mode may be protected by a four digit alphanumeric security code which must be entered to gain access. Default security code **0000** allows unrestricted access. With **R[Ed]** displayed, press **[P]** to enter a new access code. The BA377E-SS Clock will display **0000** with one digit flashing. The flashing digit may be adjusted using the **[▲]** or **[▼]** push button, when set as required operating the **[P]** button will transfer control to the next digit. When all the digits have been adjusted press **[E]** twice to return to the **R[5P]** prompt in the configuration menu. The revised security code will be activated when the BA377E-SS is returned to the display mode.

9.4.14 Security code: **[odE]**

Access to the instrument's configuration menu may be protected by a four digit alphanumeric security code which must be entered to gain access. New instruments are configured with the default security code **0000** which allows unrestricted access to all configuration functions.

To enter a new security code select **[odE]** from the configuration menu and press **[P]** which will cause the Clock to display **0000** with one digit flashing. The flashing digit may be adjusted using the **[▲]** and **[▼]** push button, when set as required operating the **[P]** button will transfer control to the next digit. When all the digits have been adjusted press **[E]** to return to the **[odE]** prompt. The revised security code will be activated when the Clock is returned to the display mode.

Please contact BEKA associates sales department if the security code is lost.

9.4.15 Reset configuration to Clock factory defaults: **r5E[dEF]**

When the BA377E-SS is configured as a Clock, this function resets the configuration to the Clock factory defaults shown in sections 9.4 of this manual.

To reset the instrument configuration select **r5E[dEF]** from the configuration menu and press **[P]**. The Clock will display **0000** with the first digit flashing which is a request to confirm the instruction by entering **5urE**. Using the **[▲]** or **[▼]** button set the first flashing digit to 5 and press **[P]** to transfer control to the second digit which should be set to **u**. When **5urE** has been entered pressing the **[E]** button will reset all the configuration functions to the factory defaults and return the instrument to the display mode as a Clock with default configuration.

10. CLOCK CONFIGURATION EXAMPLE

In this example a BA377E-SS is required to function as a Clock. Time is to be displayed in a 24 hour format including seconds. For external synchronisation the displayed time is required to change to 12 : 00 : 00 when the external reset terminals are connected together.

Both control outputs are required to close and open once in each 24 hour period. Control output 1 (OP1) is to turn *on* (close) at 07:30:00 and *off* (open) at 09:30:00, control output 2 (OP2) is to turn *on* (close) at 18:00:00 and *off* (open) at 22:30:00.

For this application the operator needs to adjust the control output *on* and *off* times from the display mode via an access code of 1111. To prevent tampering the instrument configuration menu is to be protected by security code of 1209

10.1 Configuration procedure

The BA377E-SS may be configured as a Clock on-site without disconnection from external wiring.

Step 1 Enter the configuration menu

Enter the configuration menu by simultaneously pressing **P** and **E**. Assuming a security code has not already been entered the instrument will respond by displaying *Funct, on* which is the first item in the configuration menu. See Fig 21.

Step 2 Configure instrument as a Clock

With *Funct, on* displayed press **P** to reveal the existing function of the instrument. If *ELoc* is displayed no change is required, therefore return to the *Funct, on* prompt by pressing the **E** button.

If *ELRPE* is displayed, press the **▲** or **▼** button to change the setting to *ELoc* followed by the **P** button which will result in a *0000* prompt being displayed with the first digit flashing. This is a request for the instruction to be confirmed by entering *SurE* using the **▼** and **▲** buttons to adjust the flashing digit and the **P** button to move control to the next digit. Pressing **E** will then change the instrument to a Clock and return the display to *Funct, on* in the configuration menu.

Step 3 Select display format

Using the **▲** or **▼** button select *d, SPLY* in the configuration menu and press **P** which will reveal the current display format. Using the **▲** or **▼** button select *24:00:00* which is the required 24 hour format with seconds and press **E** to enter the selection and return to the configuration menu. See 9.4.4

Step 4 Enter the synchronisation time

Using the **▲** or **▼** button select *SynE t* in the configuration menu and press **P** to reveal the current synchronisation time with the hours flashing. Using the **▲** or **▼** push button adjust the hours to 12 and press **P** to transfer control to the minutes. Using the **▲** or **▼** push button adjust the minutes to 00 and press **P** to transfer control to the seconds which should be adjusted to 00, in the same way. When the seconds are set enter the selection and return to the *SynE t* prompt in the configuration menu by pressing the **E** button. See 9.4.6

Step 5 Enable control output 1 and enter the *on* and *off* times.



Using the **▲** or **▼** button select *OP1* in the configuration menu and press **P** to reveal the *EnbL* prompt in the control output 1 sub-menu.

In this application control output 1 is required to turn *on* and *off* once every 24 hours. With *EnbL* displayed press **P** and using the **▲** or **▼** button select *on t* followed by the **E** button to return to the *EnbL* prompt.















The control output *on* time should now be entered by selecting *OP1: on t* in the control output 1 sub-menu using the **▲** or **▼** button. Pressing **P** will reveal the existing *on* time which should be adjusted to 07:30:00 using the **▲** or **▼** button and the **P** button to transfer control to the following digits. When entered return to the *OP1: on t* prompt by pressing the **E** button.

The *off* time should now be entered by selecting *OP1: off t* from the sub-menu and adjusting the time to 09:30:00. Finally press **E** to return to the *OP1: off t* prompt in the sub-menu and press **E** again to return to *OP1* in the configuration menu.







Step 6 Enable control output 2 and enter the on and off times.

Using the  or  button select *aP2* in the configuration menu and press  to reveal the *EnbL* prompt in the control output 2 sub-menu. Follow the procedure described in step 5 above, but set control output 2 to turn on at *18:00:00* and off at *22:30:00*.

Step 7 Allow control output times to be adjusted from the display mode & enter separate security code.

Using the  or  button select *RESP* in the configuration menu and press  to reveal the *EnbL* prompt, pressing  again will show if this function is *on* or *off*. Using the  or  button select *on* followed by  to return to the *EnbL* prompt. A separate security code which must be entered to gain access to the alarm times in the operating mode, is entered in the *REEd* function which may be selected by operating the  or  button once. Pressing  will reveal the existing access code with one digit flashing. This should be changed to the required code of *1111* by adjusting the flashing digit using the  or  button and the  button to transfer control to the next digit. When *1111* has been entered press  twice to return to the configuration menu.















Step 8 Define the configuration menu security code.

Defining a security code prevents unauthorised access to the configuration menu. Using the  and  buttons select *LoE* from the configuration menu and press  which will reveal *0000* with the first digit flashing. This example requires the security code to be *1209*, using the  and  buttons set the flashing digit to *1* and press  to transfer control to the second digit. When all have been entered press  to return to the main configuration menu. See 9.4.14.

Step 9 Return to the display mode

The BA377E-SS is now configured as required for this example. Pressing the  button will save the configuration and return the BA377E-SS to the display mode with all the digits flashing indicating that the set time has to be entered.

Step 10 Enter the set time

Finally the current time to be displayed by the Clock should be entered. Re-enter the configuration menu by pressing the  and  buttons simultaneously which will result in *LoE* being displayed. Pressing  will allow the access code *1209* to be entered using the  or  button to adjust the flashing digit and the  button to transfer control to the next digit. When all four digits have been adjusted press  to enter the configuration menu and using the  or  button select *SEt* and press  to reveal *00:00:00* with the hours flashing. Using the  or  button adjust the flashing hours digit and press  to transfer control to the minutes and then to the seconds. When all have been set as required, press  to start the clock from the entered time and return to the display mode.

11. MAINTENANCE when configured as a Clock

11.1 Fault finding during commissioning

If a BA377E-SS fails to function as a Clock during commissioning the following procedure should be followed:

Symptom	Cause	Check:
No display	No power supply, or incorrect wiring. Note: Terminals 2 & RS2 are interconnected within the instrument.	That there is between 10 and 28V on terminals 1 & 2 with terminal 1 positive. That there are no connections to terminals 3, 4, 5 & 6.
Configuration menu does not correspond with the Clock section of this manual.	BA377E-SS is configured as a Timer.	That Function in configuration menu is set to CLC not to ELRP5E .
Clock display flashes 00:00:00	Local time has not been entered.	Enter the local time in the SEt function of the instrument configuration menu.
Control output(s) do not function.	Control outputs have not been enabled.	Enable Control Output(s) in the configuration menu.
Clock will not start	Reset terminals RS1 and RS2 are connected together and the clock is resetting.	If reset annunciator on display is activated, disconnect link between RS1 and RS2.
Unable to enter configuration menu.	Incorrect security code	That the correct security code is being used. Contact BEKA if code is lost.

11.2 Fault finding after commissioning

ENSURE PLANT SAFETY BEFORE STARTING MAINTENANCE

Live maintenance is permitted on intrinsically safe equipment installed in a hazardous area, but only certified test equipment should be used unless a gas clearance certificate is available.

If a BA377E-SS fails after it has been functioning correctly as a Clock, the following table may help to identify the cause of the failure.

Symptom	Cause	Check:
No display	No power supply	That there is between 10 and 28V on terminals 1 & 2 with terminal 1 positive.
Clock display flashes 00:00:00	Instrument power supply has been interrupted and local time has been lost.	Enter the local time in the SEt function of the instrument configuration menu.
Control output(s) do not function.	Control outputs have not been enabled.	Enable Control Output(s) in the configuration menu.
Clock will not start	Reset terminals RS1 and RS2 are connected together and the clock is resetting.	If reset annunciator on display is activated, disconnect connection between RS1 and RS2.
Unable to enter configuration menu.	Incorrect security code	That the correct security code is being used. Contact BEKA if code is lost.

If this procedure does not reveal the cause of the fault, it is recommended that the instrument is replaced.

11.3 Servicing

We recommend that faulty BA377E-SS Clocks are returned to BEKA associates or to our local agent for repair.

11.4 Routine maintenance

The mechanical and electrical condition of the instrument should be regularly checked. Inspection frequency should be chosen to suit the environmental conditions.

11.5 Guarantee

Instruments which fail within the guarantee period should be returned to BEKA associates or our local agent. It is helpful if a brief description of the fault symptoms is provided.

11.6 Customer comments

BEKA is always pleased to receive comments from customers about our products and services. All communications are acknowledged and whenever possible, suggestions are implemented.

Appendix 1 Dust certification

A1.0 ATEX dust certification

In addition to ATEX certification permitting installation in explosive gas atmospheres which is described in the main section of this instruction manual, the BA377E-SS Timer or Clock has ATEX certification permitting installation in combustible dust atmospheres.

This appendix describes ATEX installations in explosive dust atmospheres conforming with EN 60079-14 *Electrical installations design, selection and erection*. When designing systems for installation outside the UK the local Code of Practice should be consulted.

The Timer or Clock's dust input and output safety parameters are identical to its gas parameters, therefore all the electrical circuits shown in the main section of this manual may also be used for dust applications. Intrinsically safe systems in dust atmospheres only have to comply with IIB requirements. Apparatus certificates for intrinsically safe interfaces usually specify Co and Lo for IIC gases, but for use with apparatus in dust atmospheres these may be increased to the IIB figures. For a IIC interface with a Uo of 28V and an Io of 93mA, Co increases from 83nF to 650nF and Lo increases by a factor of 4 for IIB.

A1.1 Zones, and Maximum Surface Temperature.

The BA377E-SS has been ATEX dust certified as

Group II, Category 1D
Ex ia IIIC T80°C Da $-40 \leq Ta \leq 60^\circ\text{C}$

When connected to a suitable system the BA377E-SS may be installed in:

- | | |
|---------|--|
| Zone 20 | explosive atmosphere in the form of a cloud of combustible dust in air is continuously present, or for long periods or frequently. |
| Zone 21 | explosive atmosphere in the form of a cloud of combustible dust in air is likely to occur occasionally in normal operation. |
| Zone 22 | explosive atmosphere in the form of a cloud of combustible dust in air is not likely to occur in normal operation, but if it does occur, will only persist for a short period. |

Be used with dust in subdivisions:

- | | |
|------|--|
| IIIA | combustible flyings |
| IIIB | non-conductive dust |
| IIIC | conductive dust
<i>(For use with IIIC conductive dusts special conditions for safe use apply – see section A1.4)</i> |

Having a Minimum Ignition Temperature of:

- | | |
|---|----------------------|
| Dust cloud | 120°C |
| Dust layer on indicator up to 5mm thick | 155°C |
| Dust layer on indicator over 5mm thick. | Refer to EN 60079-14 |

At an ambient temperature between -40 and +60°C

A1.3 Maintenance

ENSURE PLANT SAFETY BEFORE STARTING MAINTENANCE

Live maintenance is permitted on intrinsically safe equipment installed in a hazardous area, but only certified test equipment should be used.

The BA377E-SS has IP66 front of panel protection and a gasket is provided to seal the joint between the instrument and the mounting panel thus preventing dust ingress from the outside. The rear of the instrument has IP20 protection therefore when used in any dust application the panel enclosure in which the instrument is mounted should provide at least IP54 ingress protection. For applications in IIIC conductive dusts, IP6X protection is required.

A1.4 Special conditions for safe use

The ATEX certificate has an 'X' suffix indicating that special conditions for safe use are required for installation dust atmospheres, the certificate states:

- For use in group III explosive dust atmospheres the BA377E-SS shall be mounted such that the rear of the instrument has at least IP54 protection.
- For use in group IIIC conductive explosive dust atmospheres the BA377E-SS shall be mounted such that the rear terminals have at least IP6X protection.

A1.5 Installation in an Ex t panel enclosure within Zone 21 or Zone 22.

Installation of a BA377E-SS Timer or Clock in an Ex t panel enclosure does not invalidate the Ex t panel's certification as the front of BA377E-SS complies with Ex t impact and ingress requirements. Although mounted in an Ex t panel enclosure, the BA377E-SS remains Group II, Category 1D Ex ia IIIC T80°C Da intrinsically safe apparatus and therefore should be powered via a Zener barrier or galvanic isolator as described in section 4.1 and 4.2 of this manual.

The Zener barrier, galvanic isolator or associated apparatus is usually installed in the safe area as shown in Fig 22. It may be possible to mount the intrinsically safe interface in the same Ex t panel enclosure as the Timer or Clock if in normal operation the outside temperature of the enclosure is not affected.

The Timer or Clock terminals, the wiring to the Timer or Clock and the intrinsically safe interface, if mounted within the enclosure, should be segregated from all other non-intrinsically safe wiring and equipment within the panel enclosure as required by EN 60079-11 *Equipment protected by intrinsic safety* and EN 60079-14 *Electrical installations design, selection and erection*.

If live maintenance is anticipated, it is recommended that the Ex t panel enclosure should be fitted with a warning label saying 'Do not open when non-intrinsically safe circuits are energised', alternatively all bare live non-intrinsically safe parts within the panel enclosure should have an IP30 cover carrying a warning label 'Do not open when energised'.

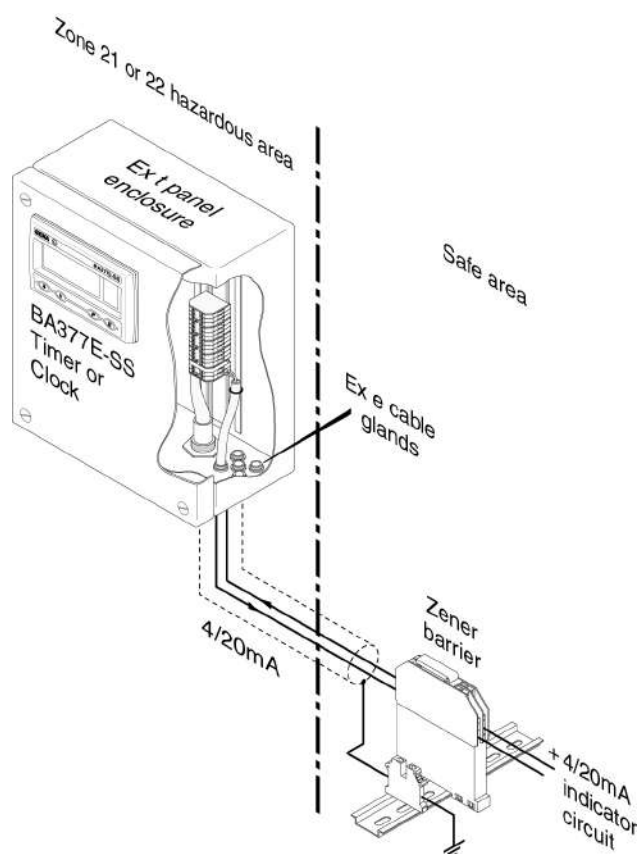

Fig 22 Typical installation in Ex t panel enclosure

Appendix 2 IECEx certification

A2.0 The IECEx Certification Scheme

IECEx is a global certification scheme for explosion protected products which aims to harmonise international certification standards. For additional information about the IECEx certification scheme and to view the BEKA associate certificates, please visit www.iecex.com

A2.1 IECEx Certificate of Conformity

The BA377E-SS Timer or Clock has been issued with an IECEx Certificate of Conformity number IECEx ITS 16.0004X which specifies the following certification code:

Ex ia IIC T5 Ga
Ex ia IIIC T 80°C Da
-40°C ≤ Ta ≤ +60°C

When installed as purely intrinsically safe apparatus i.e. when not relying upon ingress and impact resistance of the Timer or Clock front in an Ex e, Ex p, Ex n or Ex t panel enclosure ambient temperature range is increased to -40°C ≤ Ta ≤ +70°C

The IECEx certificate may be downloaded from www.beka.co.uk, www.iecex.com or requested from the BEKA sales office.

A2.2 Installation

The IECEx intrinsic safety parameters are identical to the ATEX safety parameters described in the main section of this manual and both refer to the same standards. Therefore the ATEX installation requirements specified in sections 2, 3 and Appendix 1 of this manual may be used for IECEx installations, but the local code of practice should also be consulted.

A2.3 Special conditions for safe use

The IECEx intrinsic safety certificate number has an 'X' suffix indicating that for some applications special conditions apply for safe use.

- For use in group III explosive dust atmospheres the BA377E-SS shall be mounted such that the rear of the instrument has at least IP54 protection.
- For use in group IIIC conductive explosive dust atmospheres the BA377E-SS shall be mounted such that the rear terminals have at least IP6X protection.

This means that when installed in an Ex e, Ex n, Ex p or Ex t panel enclosure the BA377E-SS remains an intrinsically safe instrument and must comply with the installation requirements shown in this manual.

The certificate also states:

The front of the stainless steel enclosure complies with the requirements for Ex e, Ex n Ex p & Ex t type of protection.

Therefore when correctly installed in a certified panel enclosure the BA377E-SS Timer or Clock will not invalidate the Ex e, Ex n, Ex p or Ex t panel enclosure certification.

Appendix 3 ETL & cETL certification for installations in USA and Canada

A2.0 cETL Mark

For installations in the USA and Canada, the BA377E-SS Timer or Clock has ETL and cETL intrinsic safety and nonincendive approval, Control Number 4008610. Copies of the Authorisation to Mark are available from the BEKA associates sales office and www.beka.co.uk

A2.1 Intrinsic safety approval

The US and Canadian standards used for assessment and certification of the BA377E-SS are listed on the cETL Authorisation to Mark.

Installations must comply with BEKA associates Control Drawing CI330-52, which is attached to this appendix.

The ETL safety parameters are the same as the ATEX and IECEx parameters, the systems shown in sections 2 and 3 of this manual may therefore also be used for US and Canadian installations subject to compliance with the local codes of practice.

ETL and cETL intrinsic safety codes

CL I Div 1 Groups A, B, C, D T5 (US IS gas, Div cert)
CL II Div 1 Groups E, F, G. CL III (US IS dust, Div cert)

Class I Zone 0 AEx ia IIC T5 Ga (US IS gas, Zone cert)
Zone 20 AEx ia IIIC T80°C Da (US IS dust, Zone cert)

Ex ia IIC T5 Ga (Canadian IS gas, Zone cert)
Ex ia IIIC T80°C Da (Canadian IS dust, Zone cert)

$-40^{\circ}\text{C} \leq T_a \leq 60^{\circ}\text{C}$

A2.2 Nonincendive approval

The BA377E-SS Timer or Clock also has ETL and cETL nonincendive approval allowing installation in Division 2 hazardous (classified) locations without the need for Zener barriers or galvanic isolators.

Installations must comply with BEKA associates Control Drawing CI330-53, which is attached to this appendix, and with the local codes of practice.

ETL and cETL nonincendive codes US & Canada

CL I Div 2 Groups A, B, C, D T5
CL II Div 2 Groups F, G CL III Div 2
 $-40^{\circ}\text{C} \leq T_a \leq 70^{\circ}\text{C}$

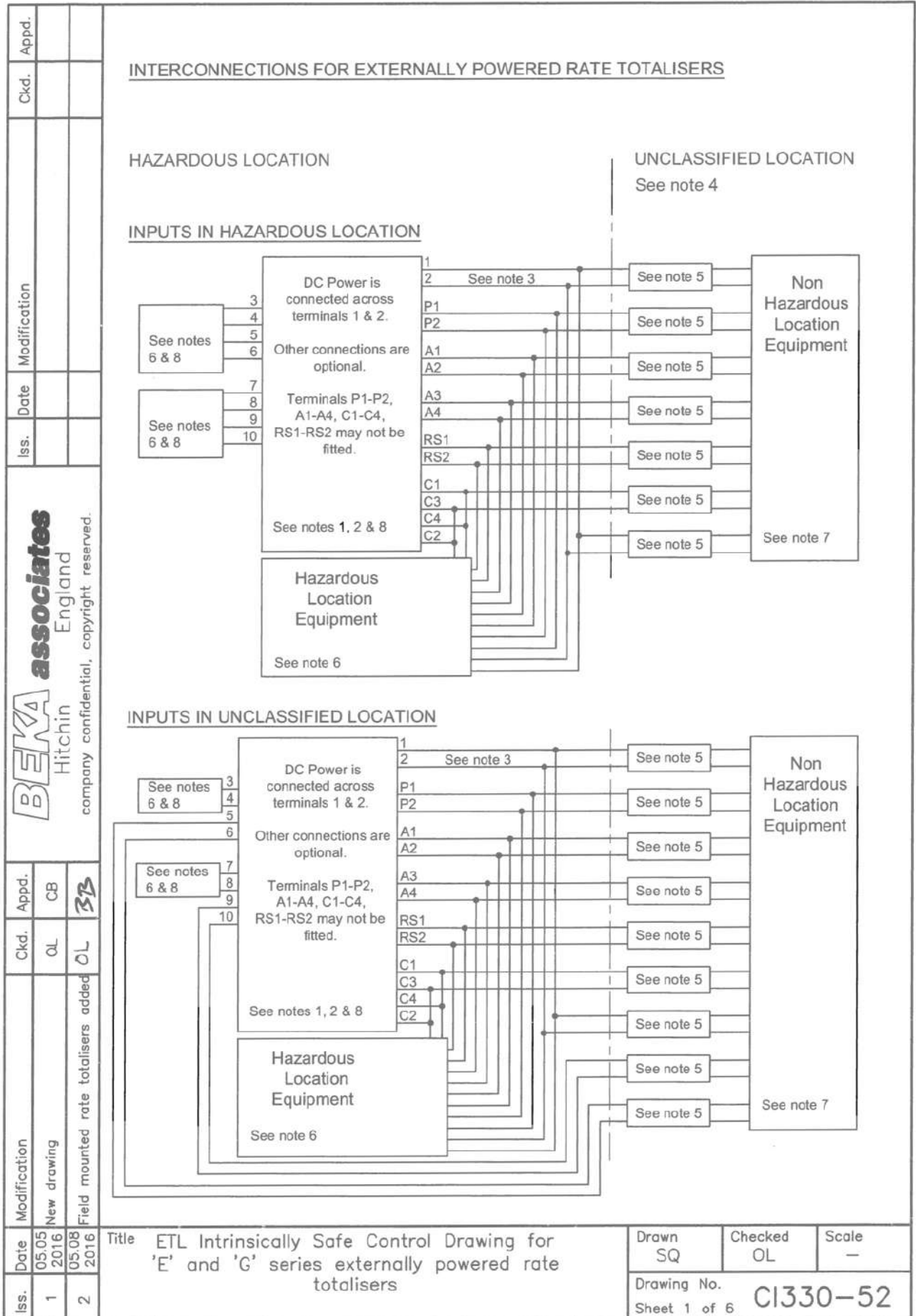

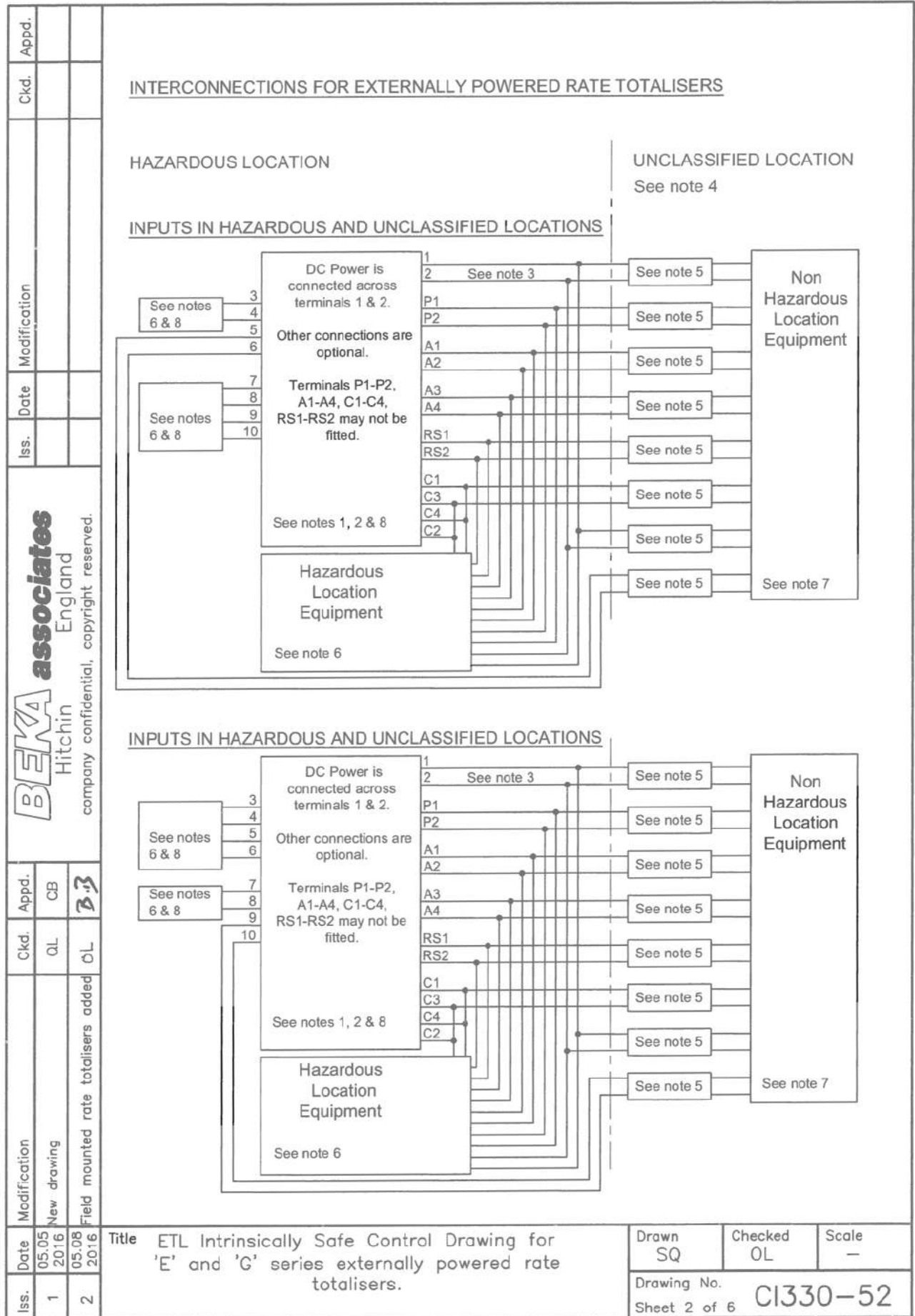



Iss.	Date	Modification	Appd.	Ckd.	Appd.	Notes
2	05.08 2016	Field mounted rate totalisers added	OL	33		

E PANEL MOUNTING INSTRUMENTS				
Type	Model Nos.	Division Marking	Zonal Marking	Ambient Temp.
1 input tachometer 1 input rate totaliser 2 input rate totaliser 1 input counter 2 input counter 1 input timer 2 input timer	BA317E BA318E BA337E BA338E BA388E BA367E BA368E BA377E BA378E	Class I Division 1 Groups A, B, C & D T5 Class II Division 1 Groups E, F & G Class III Division 1	Zone 0 AEx ia IIC T5 Ga	-40°C to +70°C
E-SS PANEL MOUNTING INSTRUMENTS				
Type	Model Nos.	Division Marking	Zonal Marking	Ambient Temp. (see note 9)
1 input tachometer 1 input rate totaliser 1 input counter 1 input timer	BA317E-SS BA337E-SS BA367E-SS BA377E-SS	Class I Division 1 Groups A, B, C & D T5 Class II Division 1 Groups E, F & G Class III Division 1	Zone 0 AEx ia IIC T5 Ga Zone 20 AEx ia IIC T80°C Da	-40°C to +60°C
G FIELD MOUNTING INSTRUMENTS				
Type	Model Nos.	Division Marking	Zonal Marking	Ambient Temp. (see note 9)
1 input tachometer 1 input rate totaliser 2 input rate totaliser 2 input counter 2 input timer	BA314G BA334G BA384G BA364G BA374G	Class I Division 1 Groups A, B, C & D T5 Class II Division 1 Groups E, F & G Class III Division 1	Zone 0 AEx ia IIC T5 Ga Zone 20 AEx ia IIC T80°C Da	-40°C to +60°C
E FIELD MOUNTING INSTRUMENTS				
Type	Model Nos.	Division Marking	Zonal Marking	Ambient Temp.
1 input tachometer 1 input rate totaliser 2 input rate totaliser 2 input counter 2 input timer	BA314E BA334E BA384E BA364E BA374E	Class I Division 1 Groups A, B, C & D T5 Class II Division 1 Groups E, F & G Class III Division 1	Zone 0 AEx ia IIC T5 Ga	-40°C to +70°C

Iss.	Date	Modification	Appd.	Ckd.	Appd.	Notes
2	05.08 2016	Field mounted rate totalisers added	OL	33		

Iss.	Date	Modification	Appd.	Ckd.	Appd.	Notes	Drawn SQ	Checked OL	Scale -
							Drawing No. Sheet 3 of 6	C1330-52	

Iss.		Date		Modification		Ckd.		Appd.			
1		05.05 2016		New drawing		OL					
2		05.08 2016		Field mounted rate totalisers added		OL		BB			
				<p>3. Installations shall be in accordance with ANSI/ISA RP 12.06.01 'Installation of Intrinsically Safe Systems for Hazardous (Classified) Locations' and the National Electrical Code ANSI/NFPA 70. Installations in Canada shall be in accordance with the Canadian Electrical Code C22.2.</p> <p>4. The associated protective barriers and galvanic isolators shall be NRTL approved and the manufacturers instructions shall be followed when installing this equipment. For installations in Canada the associated protective barriers and galvanic isolators shall be NRTL or CSA approved and the manufacturers installation drawings shall be followed when installing this equipment.</p> <p>5. One single channel or one two channel associated protective barrier or galvanic isolator with entity parameters complying with the following requirements:</p> <p>Uo equal or less than the lowest Ui of the NRTL or CSA approved apparatus installed in the loop.</p> <p>Io equal or less than the lowest li of the NRTL or CSA approved apparatus installed in the loop.</p> <p>Po equal or less than the lowest Pi of the NRTL or CSA approved apparatus installed in the loop.</p> <p>Lo equal or greater than the sum of the cable inductances and the internal inductances Li of each NRTL or CSA approved apparatus in the loop.</p> <p>Co equal or greater than the sum of the cable capacitance and the internal capacitance Ci of each NRTL or CSA approved apparatus in the loop.</p> <p>6. Simple Apparatus as defined in the National Electrical Code ANSI/NFPA 70, or for installations in Canada by the Canadian Electrical Code C22.2 OR:</p> <p>Ui equal or greater than the highest Uo of the NRTL or CSA approved apparatus powering the loop.</p> <p>li equal or greater than the highest lo of the NRTL or CSA approved apparatus powering the loop.</p> <p>Pi equal or greater than the highest Po of the NRTL or CSA approved apparatus powering the loop.</p> <p>Lo of the NRTL or CSA approved apparatus powering the loop equal or greater than the sum of the cable inductances and the internal inductances Li of each NRTL or CSA approved apparatus in the loop.</p> <p>Co of the NRTL or CSA approved apparatus powering the loop equal or greater than the sum of the cable capacitances and the internal capacitances Ci of each NRTL or CSA approved apparatus in the loop.</p>							
Title				ETL Intrinsically Safe Control Drawing for 'E' and 'G' series externally powered rate totalisers.		Drawn SQ		Checked OL		Scale -	
						Drawing No.		C1330-52			
						Sheet 4 of 6					

Iss.		Date		Modification		Ckd.		Appd.			
1		05.05.2016		New drawing		OL					
2		05.08.2016		Field mounted rate totalisers added		OL		3.3			
											
<p>7. The unclassified location equipment shall not use or generate more than 250V rms or 250V dc.</p> <p>8. Safety parameters</p> <table border="0" style="width: 100%;"> <tr> <td style="width: 50%; vertical-align: top;"> <p>DC Power terminals 1 & 2</p> <p> $U_i = 28V$ $U_o = 0$ $I_i = 200mA$ $I_o = 0$ $P_i = 0.84W$ $C_i = 2nF$ $L_i = 4\mu H$ </p> <p>Terminals 4,5,6 (input A for models in notes 6 and 7), terminals 8,9,10 (input b for models in note 7).</p> <p> $U_i = 28V$ $U_o = 1.1V$ $I_i = 200mA$ $I_o = 0.5mA$ $P_i = 0.84W$ $P_o = 0.2mW$ $C_i = 2nF$ $L_i = 4\mu H$ </p> <p>Optional pulse output terminals P1 & P2</p> <p> $U_i = 28V$ $U_o = 0$ $I_i = 200mA$ $I_o = 0$ $P_i = 0.84W$ $C_i = 0$ $L_i = 0$ </p> <p>Optional alarm output terminals A1, A2, A3 and A4</p> <p> $U_i = 28V$ $U_o = 1.47V$ $I_i = 200mA$ $I_o = 1\mu A$ $P_i = 0.84W$ $P_o = 2\mu W$ $C_i = 22nF$ $L_i = 4\mu H$ </p> </td> <td style="width: 50%; vertical-align: top;"> <p>Terminals RS1-RS2, (optional reset input)</p> <p> $U_i = 28V$ $U_o = 3.8V$ $I_i = 200mA$ $I_o = 1mA$ $P_i = 0.84W$ $P_o = 1mW$ $C_i = 0$ $L_i = 0$ </p> <p>Terminal 3,4,5,6 (input A for models in notes 6 and 7), terminals 7,8,9,10 (input b for models in note 7).</p> <p> $U_i = 14V$ $U_o = 10.5V$ $I_i = 200mA$ $I_o = 9.2mA$ $P_i = 0.7W$ $P_o = 24mW$ $C_i = 2nF$ $L_i = 4\mu H$ </p> <p>Optional 4-20mA output terminals C1, C2, C3 and C4</p> <p> $U_i = 28V$ $U_o = 0$ $I_i = 200mA$ $I_o = 0$ $P_i = 0.84W$ $C_i = 2.2nF$ $L_i = 4\mu H$ </p> </td> </tr> </table> <p>9. When installed purely as intrinsically safe equipment in division 1, division 2, zone 0, zone 1 or zone 2, the ambient temperature range of the BA317E-SS, BA337E-SS, BA367E-SS, BA377E-SS, BA314G, BA334G, BA364G, BA374G and BA384G is: $-40^{\circ}C \leq T_a \leq +70^{\circ}C$.</p>										<p>DC Power terminals 1 & 2</p> <p> $U_i = 28V$ $U_o = 0$ $I_i = 200mA$ $I_o = 0$ $P_i = 0.84W$ $C_i = 2nF$ $L_i = 4\mu H$ </p> <p>Terminals 4,5,6 (input A for models in notes 6 and 7), terminals 8,9,10 (input b for models in note 7).</p> <p> $U_i = 28V$ $U_o = 1.1V$ $I_i = 200mA$ $I_o = 0.5mA$ $P_i = 0.84W$ $P_o = 0.2mW$ $C_i = 2nF$ $L_i = 4\mu H$ </p> <p>Optional pulse output terminals P1 & P2</p> <p> $U_i = 28V$ $U_o = 0$ $I_i = 200mA$ $I_o = 0$ $P_i = 0.84W$ $C_i = 0$ $L_i = 0$ </p> <p>Optional alarm output terminals A1, A2, A3 and A4</p> <p> $U_i = 28V$ $U_o = 1.47V$ $I_i = 200mA$ $I_o = 1\mu A$ $P_i = 0.84W$ $P_o = 2\mu W$ $C_i = 22nF$ $L_i = 4\mu H$ </p>	<p>Terminals RS1-RS2, (optional reset input)</p> <p> $U_i = 28V$ $U_o = 3.8V$ $I_i = 200mA$ $I_o = 1mA$ $P_i = 0.84W$ $P_o = 1mW$ $C_i = 0$ $L_i = 0$ </p> <p>Terminal 3,4,5,6 (input A for models in notes 6 and 7), terminals 7,8,9,10 (input b for models in note 7).</p> <p> $U_i = 14V$ $U_o = 10.5V$ $I_i = 200mA$ $I_o = 9.2mA$ $P_i = 0.7W$ $P_o = 24mW$ $C_i = 2nF$ $L_i = 4\mu H$ </p> <p>Optional 4-20mA output terminals C1, C2, C3 and C4</p> <p> $U_i = 28V$ $U_o = 0$ $I_i = 200mA$ $I_o = 0$ $P_i = 0.84W$ $C_i = 2.2nF$ $L_i = 4\mu H$ </p>
<p>DC Power terminals 1 & 2</p> <p> $U_i = 28V$ $U_o = 0$ $I_i = 200mA$ $I_o = 0$ $P_i = 0.84W$ $C_i = 2nF$ $L_i = 4\mu H$ </p> <p>Terminals 4,5,6 (input A for models in notes 6 and 7), terminals 8,9,10 (input b for models in note 7).</p> <p> $U_i = 28V$ $U_o = 1.1V$ $I_i = 200mA$ $I_o = 0.5mA$ $P_i = 0.84W$ $P_o = 0.2mW$ $C_i = 2nF$ $L_i = 4\mu H$ </p> <p>Optional pulse output terminals P1 & P2</p> <p> $U_i = 28V$ $U_o = 0$ $I_i = 200mA$ $I_o = 0$ $P_i = 0.84W$ $C_i = 0$ $L_i = 0$ </p> <p>Optional alarm output terminals A1, A2, A3 and A4</p> <p> $U_i = 28V$ $U_o = 1.47V$ $I_i = 200mA$ $I_o = 1\mu A$ $P_i = 0.84W$ $P_o = 2\mu W$ $C_i = 22nF$ $L_i = 4\mu H$ </p>	<p>Terminals RS1-RS2, (optional reset input)</p> <p> $U_i = 28V$ $U_o = 3.8V$ $I_i = 200mA$ $I_o = 1mA$ $P_i = 0.84W$ $P_o = 1mW$ $C_i = 0$ $L_i = 0$ </p> <p>Terminal 3,4,5,6 (input A for models in notes 6 and 7), terminals 7,8,9,10 (input b for models in note 7).</p> <p> $U_i = 14V$ $U_o = 10.5V$ $I_i = 200mA$ $I_o = 9.2mA$ $P_i = 0.7W$ $P_o = 24mW$ $C_i = 2nF$ $L_i = 4\mu H$ </p> <p>Optional 4-20mA output terminals C1, C2, C3 and C4</p> <p> $U_i = 28V$ $U_o = 0$ $I_i = 200mA$ $I_o = 0$ $P_i = 0.84W$ $C_i = 2.2nF$ $L_i = 4\mu H$ </p>										
Title						Drawn		Checked		Scale	
ETL Intrinsically Safe Control Drawing for 'E' and 'G' series externally powered rate totalisers.						SQ		OL		-	
						Drawing No.		CI330-52			
						Sheet 5 of 6					

Iss.	Date	Modification	Ckd.	Appd.	Iss.	Date	Modification	Ckd.	Appd.	<p>10. CAUTION Aluminium and stainless steel certification labels that are mounted on the BA317E, BA318E, BA337E, BA338E, BA367E, BA368E, BA377E, BA378E and BA388E externally powered rate totaliser enclosures may be marked with their maximum capacitance (8pF). The BA317E, BA318E, BA337E, BA338E, BA367E, BA368E, BA377E, BA378E and BA388E enclosures may also carry the following potential electrostatic warning:</p> <p style="text-align: center;">WARNING</p> <p style="text-align: center;">Potential electrostatic charging hazard clean only with a damp cloth</p> <p style="text-align: center;">AVERTISSEMENT</p> <p style="text-align: center;">Risque potentiel de charge électrostatique Nettoyer uniquement avec un chiffon humide</p> <p>Alternatively, the enclosures may be manufactured from a conducting plastic per Article 250 of the National Electrical Code.</p>
1	05.05 2016	New drawing	OL	CB	1	05.08 2016	Field mounted rate totalisers added	OL	3.3	<p>12. When mounting the BA317E-SS, BA337E-SS, BA367E-SS, and BA377E-SS panel mounting externally powered rate totalisers in an AEx e, AEx n, AEx p or AEx t certified enclosure, or an enclosure to maintain IP66 front panel rating, the panel cut-out shall be:</p> <p style="margin-left: 40px;">92.0 +0.8/-0.0 x 45.0 +0.6/-0.0mm (3.62 +0.03/-0.0 x 1.77 +0.02/-0.0 inches)</p> <p style="margin-left: 40px;">4 panel mounting clamps are required and each shall be tightened to a minimum of 22cNm (1.95inLb).</p> <p style="margin-left: 40px;">When correctly installed, the BA317E-SS, BA337E-SS, BA367E-SS and BA377E-SS will not invalidate the certification of an AEx e, AEx n, AEx p or AEx t panel enclosure.</p>
2	05.08 2016	Field mounted rate totalisers added	OL	CB	<p>Title ETL Intrinsically Safe Control Drawing for 'E' and 'G' series externally powered rate totalisers.</p>					<p>Drawn SQ</p> <p>Checked OL</p> <p>Scale -</p>
					<p>Drawn No. CI330-52</p> <p>Sheet 6 of 6</p>					

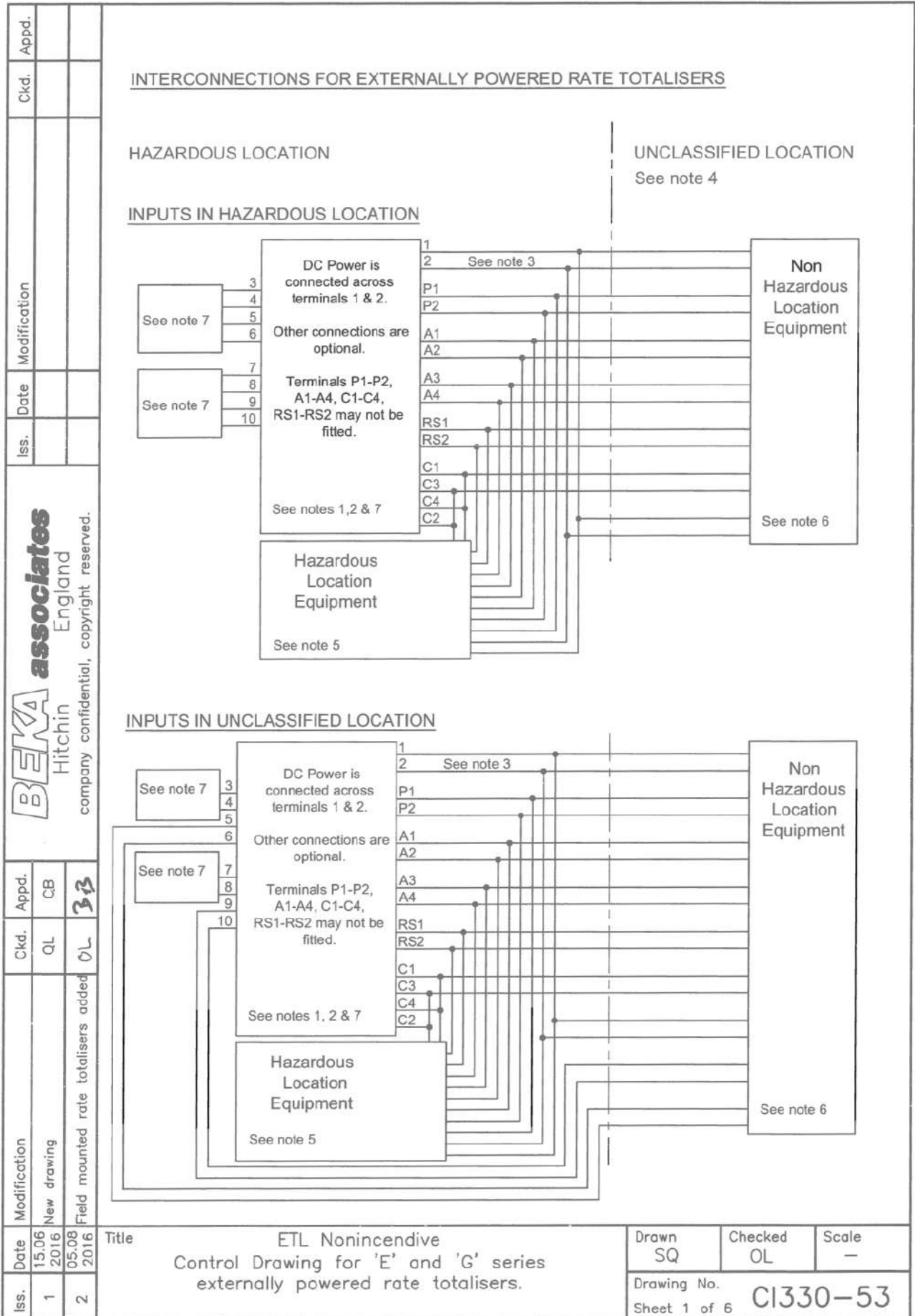

Iss.		Date		Modification		Ckd.		Appd.	
1	15.06.2016			New drawing		QL	CB		
2	05.08.2016			Field mounted rate totalisers added		OL	33		

BEKA associates
Hitчин
England
company confidential, copyright reserved.

Date	Title	Drawn	Checked	Scale
15.06.2016	ETL Nonincendive Control Drawing for 'E' and 'G' series externally powered rate totalisers.	SQ	OL	-
		Drawing No. CI330-53		
		Sheet 1 of 6		

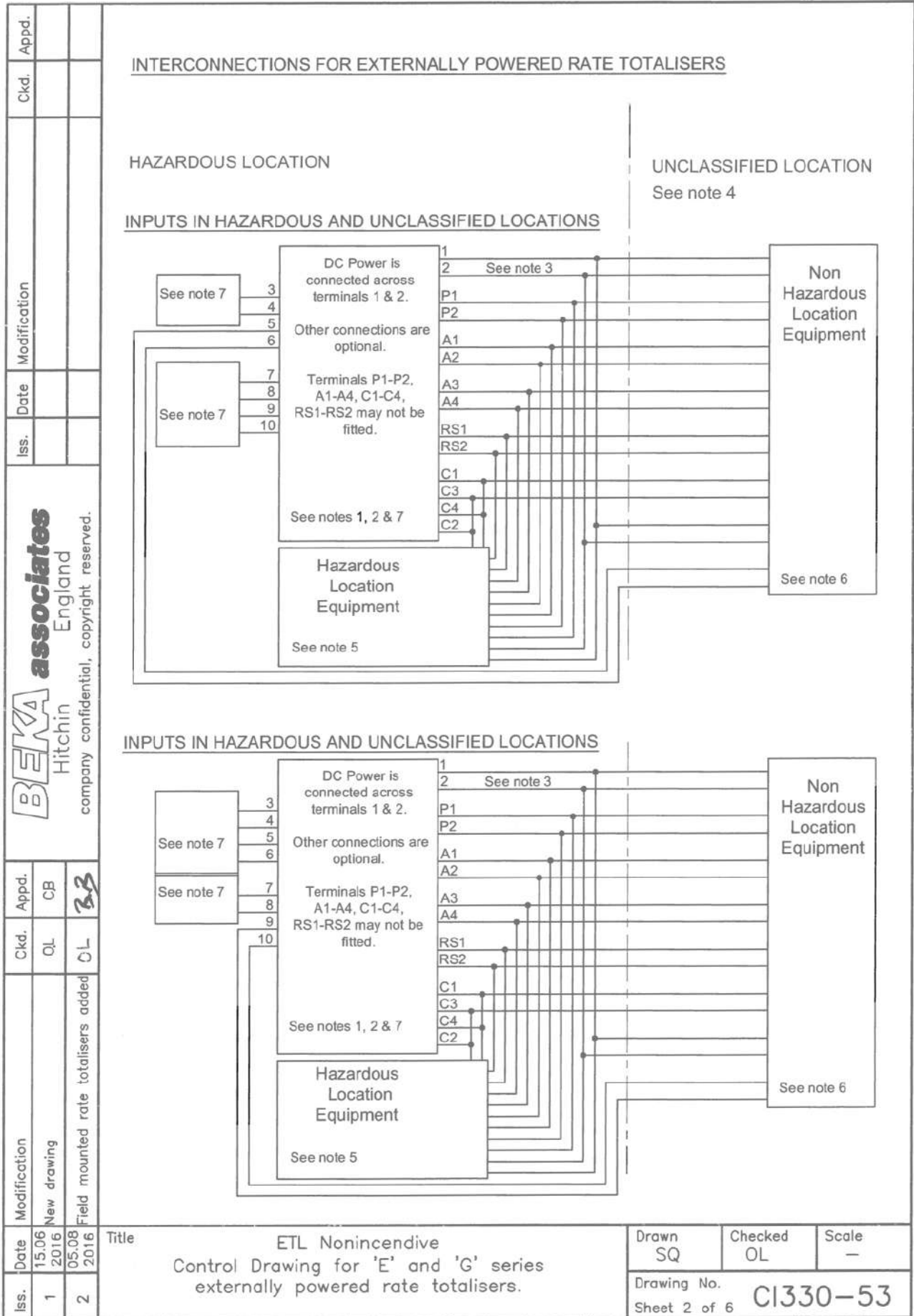

Iss.	Date	Modification	Ckd.	Appd.
1	15.06 2016	New drawing	OL	CB
2	05.08 2016	Field mounted rate totalisers added	OL	BB

BEKA associates
Hitchin
England
company confidential, copyright reserved.

Title: ETL Nonincendive Control Drawing for 'E' and 'G' series externally powered rate totalisers.

Drawn SQ	Checked OL	Scale -
Drawing No.		CI330-53
Sheet 2 of 6		

Iss.	Date	Modification	Ckd.	Appd.	Iss.	Date	Modification	Ckd.	Appd.	Notes	
											1
2	05.08 2016	Field mounted rate totalisers added	OL	3.3	<p>BEKA associates Hitchin England company confidential, copyright reserved.</p>						<p>Notes</p> <p>1. 1 and 2 input externally powered rate totalisers with model numbers and coding as shown in the following tables.</p>
NE PANEL MOUNTING INSTRUMENTS											
Type		Model Nos.	Division Marking		Zonal Marking (see note 8)		Ambient Temp. (see note 9)				
1 input tachometer 1 input rate totaliser 1 input counter 1 input timer		BA317NE BA337NE BA367NE BA377NE	Class I Division 2 Groups A, B, C & D T5 Class II Division 2 Groups F & G Class III Division 2		Zone 2 AEx nA ic IIC T5 Gc Zone 22 AEx ic tc IIIC T80°C Dc		-40°C to +60°C				
E PANEL MOUNTING INSTRUMENTS											
Type		Model Nos.	Division Marking		Zonal Marking		Ambient Temp.				
1 input tachometer 1 input rate totaliser 2 input rate totaliser 1 input counter 2 input counter 1 input timer 2 input timer		BA317E BA318E BA337E BA338E BA388E BA367E BA368E BA377E BA378E	Class I Division 2 Groups A, B, C & D T5 Class II Division 2 Groups F & G Class III Division 2		None		-40°C to +70°C				
E-SS PANEL MOUNTING INSTRUMENTS											
Type		Model Nos.	Division Marking		Zonal Marking		Ambient Temp.				
1 input tachometer 1 input rate totaliser 1 input counter 1 input timer		BA317E-SS BA337E-SS BA367E-SS BA377E-SS	Class I Division 2 Groups A, B, C & D T5 Class II Division 2 Groups F & G Class III Division 2		None		-40°C to +70°C				
NG FIELD MOUNTING INSTRUMENTS											
Type		Model Nos.	Division Marking		Zonal Marking (see note 8)		Ambient Temp. (see note 9)				
1 input tachometer 1 input rate totaliser 2 input rate totaliser 2 input counter 2 input timer		BA314NG BA334NG BA384NG BA364NG BA374NG	Class I Division 2 Groups A, B, C & D T5 Class II Division 2 Groups F & G Class III Division 2		Zone 2 AEx nA ic IIC T5 Gc Zone 22 AEx ic tc IIIC T80°C Dc		-40°C to +60°C				
G FIELD MOUNTING INSTRUMENTS											
Type		Model Nos.	Division Marking		Zonal Marking		Ambient Temp.				
1 input tachometer 1 input rate totaliser 2 input rate totaliser 2 input counter 2 input timer		BA314G BA334G BA384G BA364G BA374G	Class I Division 2 Groups A, B, C & D T5 Class II Division 2 Groups F & G Class III Division 2		None		-40°C to +70°C				
E FIELD MOUNTING INSTRUMENTS											
Type		Model Nos.	Division Marking		Zonal Marking		Ambient Temp.				
1 input tachometer 1 input rate totaliser 2 input rate totaliser 2 input counter 2 input timer		BA314E BA334E BA384E BA364E BA374E	Class I Division 2 Groups A, B, C & D T5 Class II Division 2 Groups F & G Class III Division 2		None		-40°C to +70°C				
Date		Title		Drawn		Checked		Scale			
05.05 2016		ETL Nonincendive Control Drawing for 'E' and 'G' series externally powered rate totalisers.		SQ		OL		-			
05.08 2016				Drawing No.		Sheet 3 of 6		C1330-53			

Iss.		Date		Modification		Ckd.		Appd.		<p>2. Terminals 7, 8, 9 and 10 only exist on 2 input instruments.</p> <p>3. Nonincendive field wiring installations shall be in accordance with the National Electrical Code ANSI/NFPA 70. The Nonincendive Field Wiring concept allows interconnection of Nonincendive Field Apparatus with Associated Nonincendive Field Wiring Apparatus using any of the wiring methods permitted for unclassified locations. Installations in Canada shall be in accordance with the Canadian Electrical Code C22.2.</p> <p>4. Classified location equipment shall be NRTL Approved Nonincendive Field Wiring Apparatus or simple apparatus as defined in ANSI/NFPA70. For Canadian installations classified location equipment shall be NRTL or CSA Approved Nonincendive Field Wiring Apparatus.</p> <p>5. Simple Apparatus as defined in the National Electrical Code ANSI/NFPA 70, 3r for installations in Canada by the Canadian Electrical Code C22.2 or as defined in note 2.</p> <p>6. The unclassified location equipment shall not use or generate more than 250V rms or 250V dc.</p>		
1		15.06 2016		New drawing		QL		CB				
2		05.08 2016		Field mounted rate totalisers added		OL		Z.B				
<p>BEKA associates Hitchin England company confidential, copyright reserved.</p>												
Iss.		Date		Modification		Ckd.		Appd.				
1		15.06 2016		New drawing		QL		CB				
2		05.08 2016		Field mounted rate totalisers added		OL		Z.B				
<p>BEKA associates Hitchin England company confidential, copyright reserved.</p>												
Title						Drawn		Checked			Scale	
ETL Nonincendive Control Drawing for 'E' and 'G' series externally powered rate totalisers.						SQ		OL			-	
						Drawing No.		C1330-53				
						Sheet 4 of 6						

Iss.	Date	Modification	Ckd.	Appd.		
1	15.06 2016	New drawing	OL	CB		
2	05.08 2016	Field mounted rate totalisers added	OL	AB		
 <p>BEKA associates Hitchin England company confidential, copyright reserved.</p>						
<p>7. Safety parameters</p> <table border="0" style="width: 100%;"> <tr> <td style="width: 50%; vertical-align: top;"> <p>DC Power terminals 1 & 2</p> <p>$U_i = 30V$ $I_i = 100mA$</p> <p>Terminals 4,5,6 (input A for models in notes 5 and 6), terminals 8,9,10 (input b for models in note 6).</p> <p>$U_i = 30V$ $U_o = 1.1V$ $I_o = 0.5mA$</p> <p>Optional pulse output terminals P1 & P2</p> <p>$U_i = 30V$ $I_i = 100mA$ $U_o = 0$ $I_o = 0$</p> <p>Optional alarm output terminals A1, A2, A3 and A4</p> <p>$U_i = 30V$ $I_i = 200mA$ $U_o = 1.47V$ $I_o = 1\mu A$</p> </td> <td style="width: 50%; vertical-align: top;"> <p>Terminals RS1-RS2, (optional reset input)</p> <p>$U_i = 30V$ $U_o = 3.8V$ $I_o = 1mA$</p> <p>Terminal 3,4,5,6 (for models in notes 5 and 6), terminals 7,8,9,10 (input b with terminals for models in note 6).</p> <p>$U_i = 15V$ $U_o = 10.5V$ $I_o = 9.2mA$</p> <p>Optional 4-20mA output terminals C1, C2, C3 and C4</p> <p>$U_i = 30V$ $U_o = 0$ $I_o = 0$</p> </td> </tr> </table> <p>8. The 'AEx ic' in codes refers to instrument push button contacts which are nonincendive.</p> <p>9. When installed purely as non-incendive equipment, the ambient temperature range of the BA317NE, BA337NE, BA367NE, BA377NE, BA314NG, BA334NG, BA364NG, BA374NG, and BA384NG is: $-40^{\circ}C \leq T_a \leq +70^{\circ}C$.</p>					<p>DC Power terminals 1 & 2</p> <p>$U_i = 30V$ $I_i = 100mA$</p> <p>Terminals 4,5,6 (input A for models in notes 5 and 6), terminals 8,9,10 (input b for models in note 6).</p> <p>$U_i = 30V$ $U_o = 1.1V$ $I_o = 0.5mA$</p> <p>Optional pulse output terminals P1 & P2</p> <p>$U_i = 30V$ $I_i = 100mA$ $U_o = 0$ $I_o = 0$</p> <p>Optional alarm output terminals A1, A2, A3 and A4</p> <p>$U_i = 30V$ $I_i = 200mA$ $U_o = 1.47V$ $I_o = 1\mu A$</p>	<p>Terminals RS1-RS2, (optional reset input)</p> <p>$U_i = 30V$ $U_o = 3.8V$ $I_o = 1mA$</p> <p>Terminal 3,4,5,6 (for models in notes 5 and 6), terminals 7,8,9,10 (input b with terminals for models in note 6).</p> <p>$U_i = 15V$ $U_o = 10.5V$ $I_o = 9.2mA$</p> <p>Optional 4-20mA output terminals C1, C2, C3 and C4</p> <p>$U_i = 30V$ $U_o = 0$ $I_o = 0$</p>
<p>DC Power terminals 1 & 2</p> <p>$U_i = 30V$ $I_i = 100mA$</p> <p>Terminals 4,5,6 (input A for models in notes 5 and 6), terminals 8,9,10 (input b for models in note 6).</p> <p>$U_i = 30V$ $U_o = 1.1V$ $I_o = 0.5mA$</p> <p>Optional pulse output terminals P1 & P2</p> <p>$U_i = 30V$ $I_i = 100mA$ $U_o = 0$ $I_o = 0$</p> <p>Optional alarm output terminals A1, A2, A3 and A4</p> <p>$U_i = 30V$ $I_i = 200mA$ $U_o = 1.47V$ $I_o = 1\mu A$</p>	<p>Terminals RS1-RS2, (optional reset input)</p> <p>$U_i = 30V$ $U_o = 3.8V$ $I_o = 1mA$</p> <p>Terminal 3,4,5,6 (for models in notes 5 and 6), terminals 7,8,9,10 (input b with terminals for models in note 6).</p> <p>$U_i = 15V$ $U_o = 10.5V$ $I_o = 9.2mA$</p> <p>Optional 4-20mA output terminals C1, C2, C3 and C4</p> <p>$U_i = 30V$ $U_o = 0$ $I_o = 0$</p>					
<p>Title</p> <p style="text-align: center;">ETL Nonincendive Control Drawing for 'E' and 'G' series externally powered rate totalisers.</p>			<p>Drawn SQ</p>	<p>Checked OL</p>		
			<p>Scale —</p>	<p>Drawing No. Sheet 5 of 6</p> <p style="font-size: 24pt; font-weight: bold;">C1330-53</p>		

Iss.	Date	Modification	Ckd.	Appd.	Iss.	Date	Modification	Ckd.	Appd.	<p>BEKA associates Hitchin England company confidential, copyright reserved.</p>	<p>10. CAUTION The BA317E, BA318E, BA337E, BA338E, BA367E, BA368E, BA377E, BA378E and the BA388E Externally Powered rate totaliser enclosures may carry the following potential electrostatic warning:</p> <p style="text-align: center;">WARNING</p> <p style="text-align: center;">Potential electrostatic charging hazard clean only with a damp cloth</p> <p style="text-align: center;">AVERTISSEMENT</p> <p style="text-align: center;">Risque potentiel de charge électrostatique Nettoyer uniquement avec un chiffon humide</p> <p>Alternatively, the enclosures may be manufactured from a conducting plastic per Article 250 of the National Electrical Code.</p>							
												<p>11. When mounting the BA317E, BA318E, BA337E, BA338E, BA367E, BA368E, BA377E, BA378E, BA388E, BA317E-SS, BA337E-SS, BA367E-SS, BA377E-SS, BA317NE, BA337NE, BA367NE & BA377NE panel mounting Externally Powered Rate Totalisers in an enclosure to maintain Type 4 front panel rating:</p> <p style="text-align: center;">Minimum panel thickness should be 2mm (0.08inches) Steel 3mm (0.12inches) Aluminium</p> <p>Outside panel finish should be smooth, free from particles, inclusions, runs or build-ups around cut-out.</p> <p>Panel cut-out for BA317E, BA337E, BA367E, and BA377E shall be: 90.0 x 43.5mm -0.0 +0.5mm (3.54 x 1.71 inches -0.00 +0.02)</p> <p>Two panel mounting clips are required for BA317E, BA337E, BA367E, and BA377E and each shall be tightened to between: 20 & 22cNm (1.77 to 1.95inLb)</p> <p>Panel cut-out for BA318E, BA338E, BA368E, BA378E, and BA388E shall be: 136.0 x 66.2mm -0.0 +0.5mm (5.35 x 2.60 inches -0.00 +0.02)</p> <p>Four panel mounting clips are required for BA318E, BA338E, BA368E, BA378E, and BA388E and each shall be tightened to between: 20 & 22cNm (1.77 to 1.95inLb)</p> <p>Panel cut-out for BA317E-SS, BA337E-SS, BA367E-SS, BA377E-SS, BA317NE, BA337NE, BA367NE & BA377NE shall be: (92.0mm -0.0 +0.8) x (45.0mm -0.0 +0.6) (3.62 inches -0.00 +0.03) x (1.77 inches - 0.00 +0.02)</p> <p>Four panel mounting clips are required for BA317E-SS, BA337E-SS, BA367E-SS, BA377E-SS, BA317NE, BA337NE, BA367NE & BA377NE and each shall be tightened to at least: 22cNm (1.95inLb)</p>						
1	15.06 2016	New drawing	OL	CB	1						<p>Title</p> <p style="text-align: center;">ETL Nonincendive Control Drawing for 'E' and 'G' series externally powered rate totalisers.</p>	<table border="1"> <tr> <td>Drawn SQ</td> <td>Checked OL</td> <td>Scale -</td> </tr> <tr> <td colspan="2">Drawing No. Sheet 6 of 6</td> <td style="text-align: center; font-size: 1.2em;">CI330-53</td> </tr> </table>	Drawn SQ	Checked OL	Scale -	Drawing No. Sheet 6 of 6		CI330-53
Drawn SQ	Checked OL	Scale -																
Drawing No. Sheet 6 of 6		CI330-53																
2	05.08 2016	Field mounted rate totalisers added	OL	B.B	2													