

1. DESCRIPTION

The BA304G-SS-PM and the BA324G-SS-PM are panel mounting intrinsically safe digital indicators that display the current flowing in a 4/20mA loop in engineering units. They are loop powered, but only introduce a 1.2V drop into the loop.

Both models are electrically similar, but have different size displays.

BA304G-SS-PM 4 digits 34mm high
316 stainless steel enclosure

BA324G-SS-PM 5 digits 29mm high + 31 segment bargraph
316 stainless steel enclosure

This abbreviated instruction sheet is intended to assist with installation and commissioning, a comprehensive manual describing safety certification, system design and calibration is available from the BEKA sales office or may be downloaded from our website.

Both models have ATEX and IECEx gas and dust intrinsic safety certification. The certification label which is located on the top of the instrument enclosure shows the certificate numbers and certification codes. Copies of certificates can be downloaded from www.beka.co.uk.

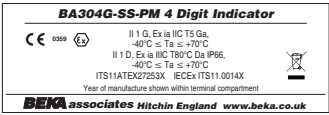

Typical certification information label

1.1 Installation in certified enclosure

In addition to conventional intrinsic safety certification, these indicators may be installed in a certified Ex e, Ex p or Ex t panel enclosure without invalidating the panel enclosure's certification. Please see the full instruction manual for details.

- When installed in an Ex e panel enclosure, the indicator should be powered by an appropriately rated Zener barrier or galvanic isolator located in a safe area.
- When pressurised, an Ex pyb enclosure reduces the equipment protection level (EPL) inside the enclosure from Gb (Zone 1) to Gc (Zone 2). When correctly installed in an Ex pyb enclosure the indicator should be powered by an appropriately rated Zener barrier or galvanic isolator located in a safe area.
- When pressurised, an Ex pxb enclosure reduces the equipment protection level (EPL) inside the enclosure from Gb (Zone 1) to non-hazardous. When correctly installed in an Ex pxb enclosure the indicator may therefore be used without a Zener barrier or galvanic isolator.

- When pressurised, an Ex pzc enclosure reduces the equipment protection level (EPL) inside the enclosure from Gc (Zone 2) to non-hazardous. When correctly installed in an Ex pzc enclosure the indicator may therefore be used without a Zener barrier or galvanic isolator.
- When correctly installed in a certified Ex t enclosure the indicator may be used without a Zener barrier or galvanic isolator.

2. INSTALLATION

Both models have a 316 stainless steel cast front panel with a toughened glass window which are impact resistant and provide IP66 protection. The rear of the instrument has IP20 protection.

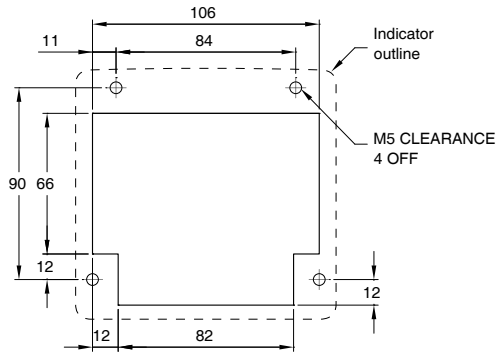
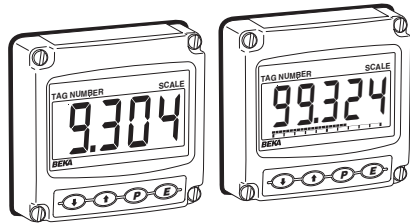

Fig 1 Recommended panel cut-out dimensions

**Abbreviated Instruction for
BA304G-SS-PM & BA324G-SS-PM
intrinsically safe panel mounting
loop powered indicators**



Issue 1
12th September 2018

BEKA associates Ltd. Old Charlton Rd, Hitchin, Hertfordshire, SG5 2DA, UK
Tel: +44(0)1462 438301 Fax: +44(0)1462 453971
e-mail: sales@beka.co.uk web: www.beka.co.uk

Both models are CE marked to show compliance with the European Explosive Atmospheres Directive 2014/34/EU and the European EMC Directive 2014/30/EU

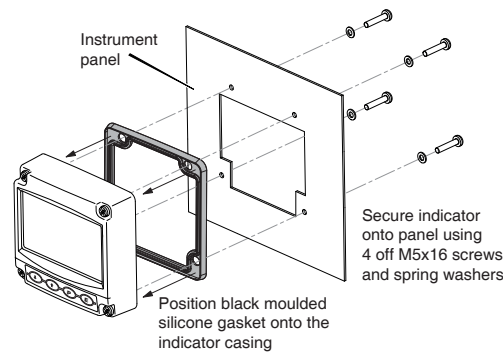
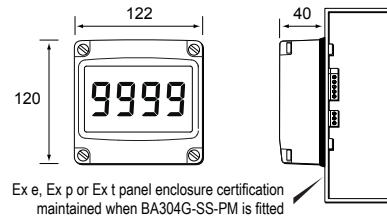

Fig 2 Installation procedure



Ex e, Ex p or Ex t panel enclosure certification maintained when BA304G-SS-PM is fitted

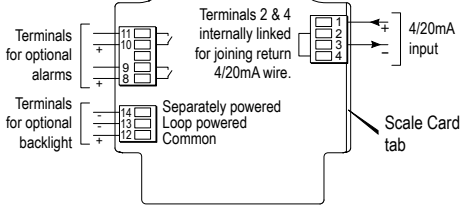

Fig 3 Terminals and overall dimensions

EMC

For specified immunity all wiring should be in screened twisted pairs, with the screens earthed in the safe area.

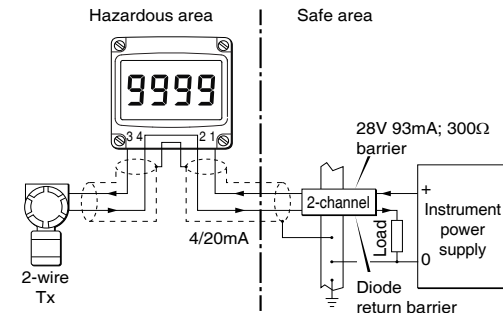

Fig 4 Typical measurement loop

Scale card

The indicator's units of measurement and tag information are shown above the display on a slide-in scale card. New instruments are fitted with a scale card showing the

information requested when the instrument was ordered, if this is not provided a blank scale card will be fitted which can easily be marked on-site. Custom printed scale cards are available from BEKA associates.

To remove the scale card, carefully pull the tab perpendicularly away from the rear of the indicator assembly. See Fig 3 for the location of the scale card tab.

To replace the scale card carefully insert it into the slot on the right hand side of the input terminals which is shown in Fig 3. Force should be applied evenly to both sides of the scale card to prevent it twisting. The card should be inserted until about 2mm of the transparent tab remains protruding.

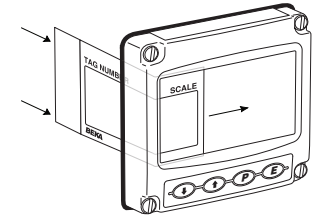

Fig 5 Inserting scale card into the instrument assembly.

3. OPERATION

All models are controlled and calibrated via four front panel push buttons. In the display mode i.e. when the indicator is displaying a process variable, these push buttons have the following functions:

- [P]** While this button is pushed the indicator will display the input current in mA, or as a percentage of the instrument span depending upon how the indicator has been configured. When the button is released the normal display in engineering units will return. The function of this push button is modified when optional alarms are fitted to the indicator.
- [V]** While this button is pushed the indicator will display the numerical value and analogue bargraph* the indicator has been calibrated to display with a 4mAΦ input. When released the normal display in engineering units will return.
- [▲]** While this button is pushed the indicator will display the numerical value and analogue bargraph* the indicator has been calibrated to display with a 20mAΦ input. When released the normal display in engineering units will return.
- [E]** No function in the display mode unless the tare function is being used.
- [P] + [V]** Indicator displays firmware number followed by version.
- [P] + [▲]** Provides direct access to the alarm setpoints when the indicator is fitted with optional alarms and the RCLSP access setpoints function has been enabled.
- [P] + [E]** Provides access to the configuration menu via optional security code.

Note

* BA324G-SS-PM only
Φ If the indicator has been calibrated using the CAL function, calibration points may not be 4 and 20mA.

4. CONFIGURATION

Indicators are supplied calibrated as requested when ordered, if not specified default configuration will be supplied but can easily be changed on-site.

Fig 6 shows the location of each function within the configuration menu with a brief summary of the function. Please refer to the full instruction manual for detailed configuration information and for a description of the lineariser and the optional dual alarms.

Access to the configuration menu is obtained by pressing the **[P]** and **[E]** buttons simultaneously. If the indicator security code is set to the default 0000 the first parameter **Func** will be displayed. If the indicator is protected by a security code, **Code** will be displayed and the code must be entered to obtain access to the menu.

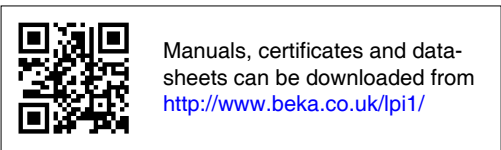
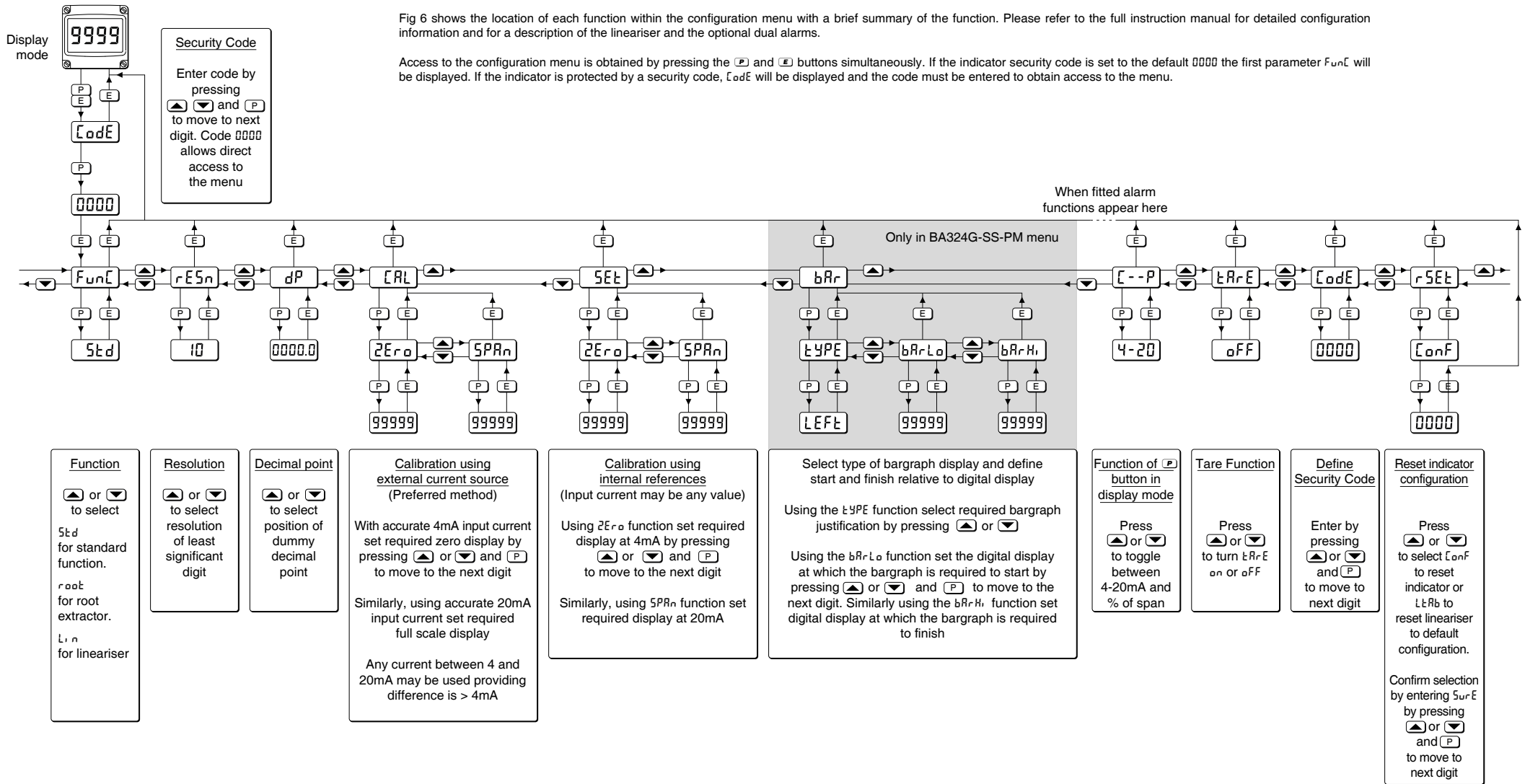

Fig 6 Configuration menu