

1. Introduction

The BR385 is a third generation intrinsically safe sounder which produces a loud warning signal in a hazardous area. Forty nine different first stage alarm sounds can be selected by internal switches, and each one can be externally changed to a second or third stage alarm sound - see tone table on the BR385 datasheet.



BR385 Intrinsically safe sounder

2. Description

Fig 1 shows a simplified block diagram of a BR385 sounder. The device operates immediately power is applied to terminals + and - which are duplicated to allow a second sounder to be connected in parallel, or for an end of line monitoring resistor to be installed. The output tone is defined by the positions of the six internal switches, this tone can be changed to a second or third stage alarm tone by connecting terminal S2 or S3 to 0V (terminal -). The tone generator is crystal controlled to ensure that when two sounders are started at the same time the output tones remain synchronised.

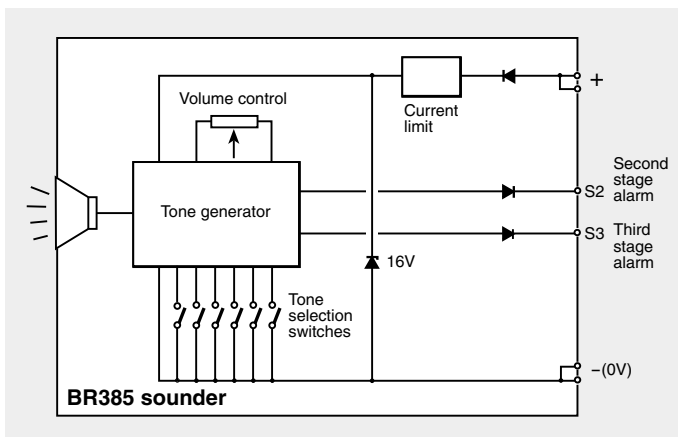

Fig 1 Simplified block diagram

3. Supply voltage

The BR385 sounder has been designed to operate in a hazardous area from an 8 to 28V dc supply via a Zener barrier or galvanic isolator. The sounder may be tested or used in safe areas without a Zener barrier or galvanic isolator, but at supply voltages above 16V the internal thermal current limit will function and the audio output may be reduced. Direct connection to supplies up to 28V of either polarity without a Zener barrier or galvanic isolator will not damage the sounder, but it is recommended that it is not operated continuously with a supply greater than 16V.

4. ATEX Intrinsic Safety Certification for Installation in Europe.

The BR385 complies with the European ATEX Directive 2014/34/EU and has been issued with a Group II, Category 1G, EU-Type Examination Certificate. Subject to local codes of practice, the sounder may be installed in any of the European Economic Area (EEA) member countries. ATEX certificates are also acceptable for installations in Switzerland.

4.1 Zones, Gas Groups and T rating

The BR385 has been certified Category IIG Ex ia IIC T4 Ga. When connected to an approved system the sounder may be installed in:

Zone 0	explosive gas air mixture continuously present.
Zone 1	explosive gas air mixture likely to occur in normal operation.
Zone 2	explosive gas air mixture not likely to occur, and if it does, it will only exist for a short time.

Be used with gases in groups:

Group A	propane
Group B	ethylene
Group C	hydrogen

Having a temperature classification of:

T1	450°C
T2	300°C
T3	200°C
T4	135°C

At ambient temperatures between -40 and +60 °C.

4.2 Terminals + and -

Power is supplied to the sounder via terminals + and - which have the following input safety parameters:

U _i	=	28V
I _i	=	93mA dc
P _i	=	0.66W

BR385 sounders may therefore be powered from any Zener barrier or galvanic isolator certified Ex ia by an EC Approved Notified Body, having output parameters equal to, or less than 28V, 93mA and 0.66W.

The equivalent internal capacitance C_i and inductance L_i at these terminals are both zero.

Caution

Please note that the input safety parameters for the earlier BA385 sounder were U_i = 28V, I_i = 110mA, P_i 0.8W. Care should therefore be taken when replacing a BA385 with a BR385 sounder to ensure that the lower input safety parameters of the new model are not exceeded.

4.3 Terminals S2 and S3

When sounder terminals S2 or S3 are connected to terminal -(0V), the sounder output tone changes to the second or third stage alarm respectively. The input safety parameters for these terminals are:

U _i	=	28V
I _i	=	0mA

Because the permitted input current is zero, these terminals may only be connected to a certified diode return barrier or to the contacts of a certified intrinsically safe relay or galvanic isolator. For operational reasons, only diode return barriers with a voltage drop of 0.9V or less may be used.

The equivalent internal capacitance C_i and inductance L_i of these terminals are both zero.

5. IECEx Intrinsic Safety Certification for international use.

5.1 The IECEx Certification Scheme

IECEx is a global certification scheme for explosion protected products which aims to harmonise international certification standards. For additional information about the IECEx certification scheme and to view the BEKA associate certificates, please visit www.iecex.com.

5.2 IECEx Certificate of Conformity

The BR385 sounder has been issued with an IECEx Certificate of Conformity number IECEx SIR 17.0014X which specifies the following certification code:

Ex ia IIC T4 Ga -40°C ≤ Ta ≤ +60°C.

The IECEx certificate may be downloaded from www.beka.co.uk, www.iecex.com or requested from the BEKA sales office.

The IECEx intrinsic safety parameters are identical to the ATEX safety parameters described in section 4 of this guide and both certificates refer to equivalent IEC and BS EN standards. Therefore the systems described in sections 7 to 11 of this guide may be used for both ATEX and IECEx installations.

6. Factory Mutual certification for installation in the USA.

For installations in the USA the BR385 sounder has FM intrinsic safety certification permitting installation in Class I; Division 1; Groups A, B, C & D and in Class I; Zone 0; Group IIC. Installations must comply with the BEKA Control Drawing CI385-32.

6.1 FM Certificate of Compliance

The FM Certificate of Compliance 3027157 and the associated BEKA Control Drawing CI385-32 may be downloaded from www.beka.co.uk, or requested from the BEKA sales office or our US agent Exloc Instruments.

6.2 Divisions / Zones, Gas Groups and T rating

The BR385 sounder has been approved intrinsically safe by FM for installation in the following Divisions / Zones and used with the following hazards.

Installation in:

Division 1	Ignitable concentrations of flammable gases, vapours or liquids can exist all of the time or some of the time under normal operating conditions.
Division 2	Ignitable concentrations of flammable gases, vapours or liquids are not likely to exist under normal operating conditions.
Zone 0	Explosive gas air mixture continuously present.
Zone 1	Explosive gas air mixture likely to occur in normal operation.
Zone 2	Explosive gas air mixture not likely to occur, and if it does, it will only exist for a short time.

Use with gases in groups:

Group A	Acetylene
Group B	Hydrogen
Group C	Ethylene
Group D	Propane
IIA	Propane
IIB	Ethylene
IIC	Hydrogen

Having a temperature classification of:

T1	450°C
T2	300°C
T3	200°C
T4	135°C

at an ambient temperature between -20°C and +60°C

6.3 Intrinsic safety parameters

The BR385 sounder has been assessed using the entity concept and the FM safety parameters are identical to the ATEX and IECEx safety parameters except that output parameters U_o , I_o and P_o are specified for the tone changing terminals S2 and S3. U_o limits the maximum cable capacitance to 390nF in gas group B and IIC (hydrogen) when the terminals are connected to an isolated contact. This is unlikely to be restrictive. U_o is unlikely to reduce the permitted cable capacitance when the terminals are connected to a diode return barrier or galvanic isolator in the safe area, but I_o should be considered when determining the maximum permitted cable inductance, but again is unlikely to be restrictive.

7. Electrical System Design for Installation in Hazardous Areas using Zener barriers.

The recommended circuits in this section may be used for installations covered by ATEX, IECEx and FM certification.

7.1 Single stage alarm

The BR385 sounder may be powered from any appropriately certified Zener barrier having output parameters equal to or less 28V, 93mA, 0.66W. If the sounder control switch is in series with the positive supply, or the power supply is being turned on and off, only a single channel Zener barrier is required to power the sounder as shown in Fig 2. This circuit may also be used if a mechanically activated switch on the hazardous area side of the barrier is controlling the sounder.

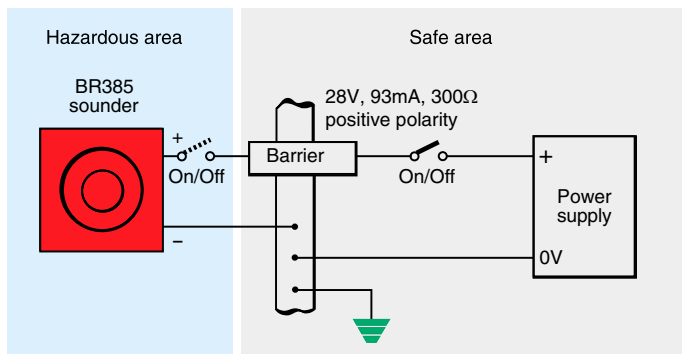

Fig 2 Single stage alarm using channel barrier

If the sounder control switch is in series with the negative supply, a second barrier is required as shown in Fig 3. A diode return barrier is ideal for this application, any type may be used providing it has the same polarity as the barrier supplying the sounder and its output safety parameters are equal to, or less than 28V and 0mA.

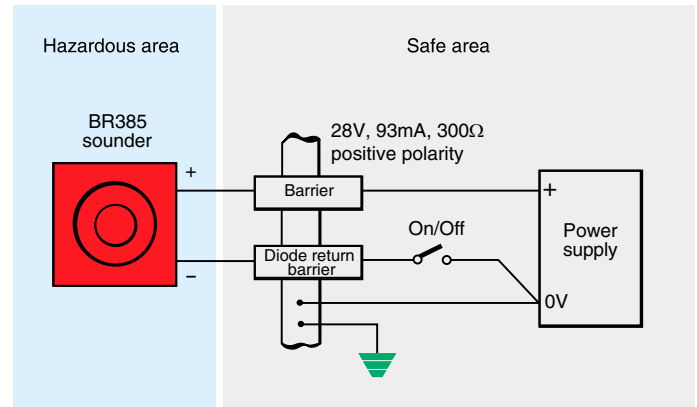

Fig 3 Single stage alarm using two channel barrier

7.2 Multi-stage alarm

Connecting sounder terminals S2 to 0V (terminal -) activates the second stage alarm; similarly connecting sounder terminals S3 to 0V (terminal -) activates the third stage alarm. Mechanically operated switches in the hazardous area may be used to select these alarm stages, or the control may be transferred from the safe (unclassified) area via an intrinsically safe relay or diode return barrier. Fig 4 shows how diode return barriers may be used. If only two alarm stages are required the third stage barrier should be omitted. For a two stage alarm the required 28V, 93mA Zener barrier plus a diode return barrier is an industry standard combination available in a common package from a variety of manufacturers. For operational reasons, only diode return barriers with a voltage drop of 0.9V or less may be used.

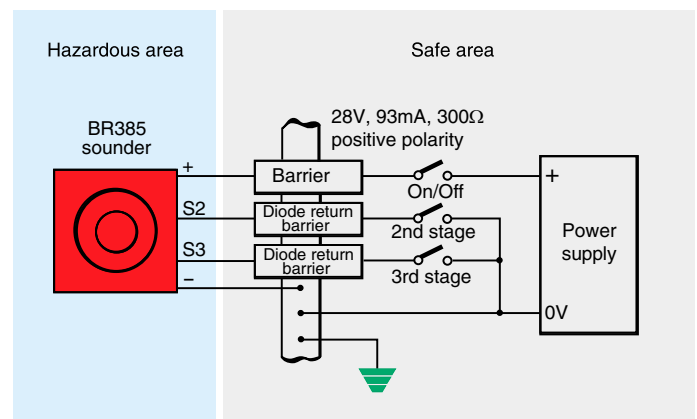

Fig 4 Multi-stage alarm using Zener barrier

8. Electrical System Design for Installation in Hazardous Areas using Galvanic isolators.

Galvanic isolators, although more expensive than Zener barriers, do not require a high integrity earth connection. For small systems where a high integrity earth is not already available, the use of galvanic isolators often reduces the overall installation cost and simplifies design.

8.1 Single stage alarm

The BR385 sounder may be powered from any appropriately certified galvanic isolator having output parameters equal to or less than the maximum input parameters specified by the sounders certification. The sounder may be controlled by turning the galvanic isolator on and off, by

a mechanically operated switch in the hazardous area wiring, or with some isolators via a dedicated safe area switch - see Fig 5.

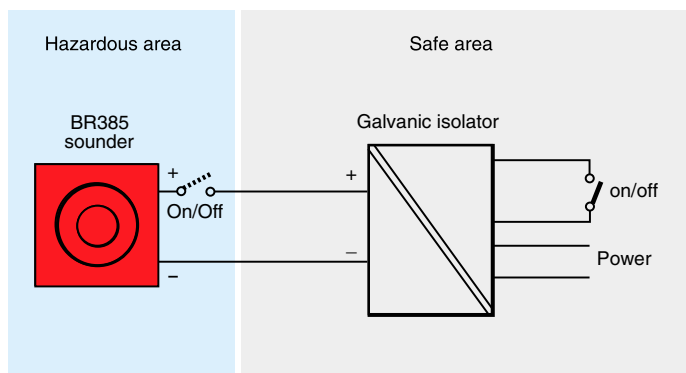

Fig 5 Single stage alarm using galvanic isolator

8.2 Multi-stage alarm

Fig 6 shows a typical application in which the BR385 sounder is activated when Alarm 1 of a BA327E intrinsically safe loop powered indicator closes. When Alarm 2 closes and the sounder output changes from the first to the second stage tone.

The indicator has galvanically isolated solid state switch outputs which have been certified as *simple apparatus*, allowing direct connection to the BR385 sounder.

9. Cable parameters

The internal capacitance C_i and inductance L_i of all sounder input terminals is zero, therefore the maximum permitted cable parameters for all configurations is determined by C_o and L_o of the Zener barrier or galvanic isolator powering and controlling the sounder. The FM certification also defines the output parameters of terminals S2 and S3 - see section 6.3 for details.

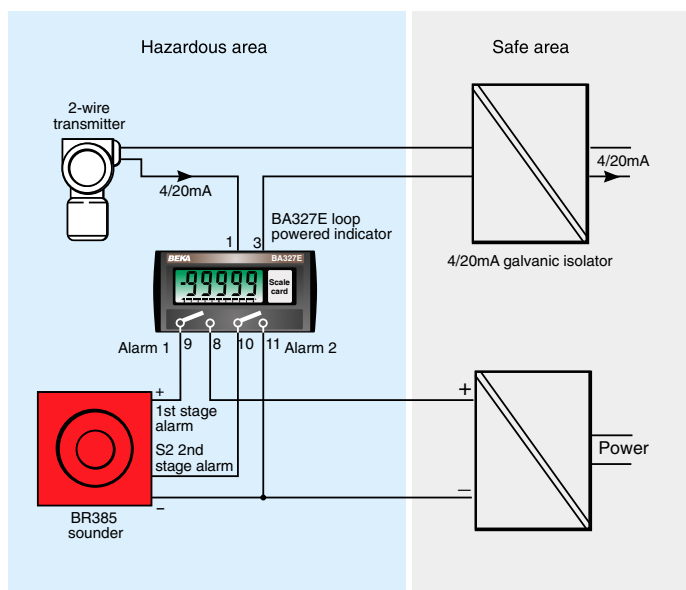

Fig 6 Loop-powered BA327E intrinsically safe indicator controlling BR385 first and second stage alarms.

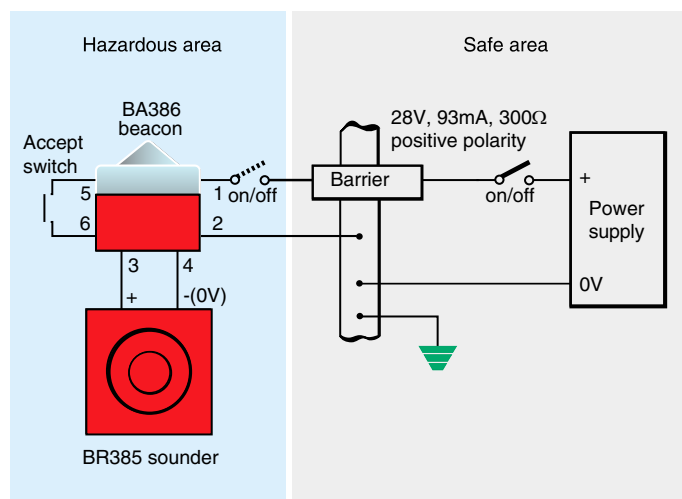

Fig 7 Combined circuit for BR385 sounder and BA386 beacon

10. Operating BR385 sounders in parallel

Two BR385 sounders may be powered from a single Zener barrier or galvanic isolator, but the output of each one will be reduced by about 3dB. It is possible to operate three devices in parallel, but this should only be done when the maximum supply voltage is available.

11. Use with BA386 LED flashing Beacon

The BR385 sounder may be powered from a BA386 intrinsically safe flashing beacon to form a combined audio-visual alarm with an alarm accept push button which silences the sounder. This combination is ideal for applications where an operator needs to be advised that an alarm condition has occurred, but wishes to silence the intrusive audible warning while leaving the beacon flashing. If the alarm condition is not corrected during the pre-set silence period, which can be between 1 and 30 minutes, the sounder will be reactivated when the silence time has expired.

The BEKA BA386 flashing beacon has ATEX and FM intrinsic safety certification and will receive IECEx certification in September 2017. The ATEX and IECEx beacon certification documents mention the beacons ability to power a sounder which may be connected using entity parameters.

The FM BA386 beacon certification mentions the earlier BEKA BA385 sounder which was electrically similar to the BR385. The BR385 sounder may be safely connected to a BA386 beacon in FM systems using entity parameters.