

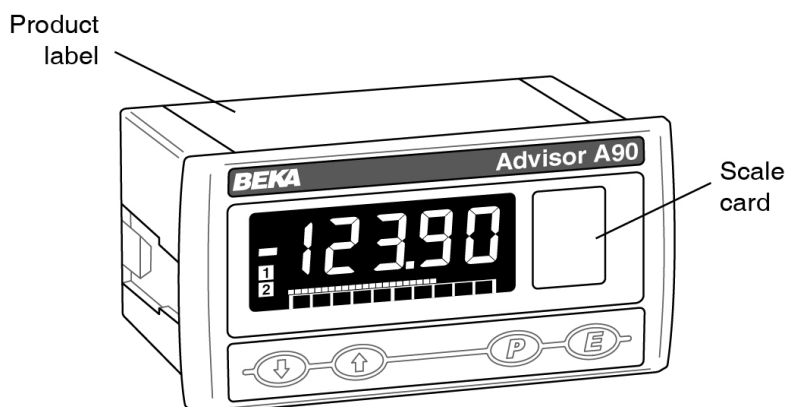

Advisor A90
Universal process
panel meter with
multicolour display
Issue 4



CONTENTS

1. **Description**
2. **Operation**
 - 2.1 Controls
3. **Applications**
 - 3.1 Power supply
 - 3.1.1 Mains powered version
 - 3.1.2 DC powered version
 - 3.2 Signal inputs
 - 3.2.1 Current input
 - 3.2.2 Voltage input
 - 3.2.3 Resistance thermometer input
4. **Installation**
 - 4.1 Location
 - 4.2 EMC
 - 4.3 Installation procedure
 - 4.4 Scale card
5. **Configuration and Calibration**
 - 5.1 Summary of configuration functions.
 - 5.2 Input type: $INPUt$
 - 5.3 Meter function: $FUNCT$
 - 5.4 Loop break detection: $LFLo$
 - 5.4.1 With optional alarm outputs
 - 5.4.2 With optional 4/20mA output
 - 5.5 Units of temperature: dEG
 - 5.6 Display resolution: $rESn$
 - 5.7 Decimal point: dP
 - 5.8 Calibration of digital display using external source: ERL
 - 5.9 Calibration of digital display using internal reference: SEt
 - 5.10 Trim temperature display: Tr
 - 5.11 Bargraph format and calibration: bRR
 - 5.12 Function of  push button: $u - - P$
 - 5.13 Tare function: $tRR-E$
 - 5.14 Maximum and minimum hold function: $Hold$
 - 5.15 Select meter display colour: $CoLoR$
 - 5.16 Security code: $CoDE$
 - 5.17 Reset to factory defaults: $rSEt$
 - 5.18 Under and overrange
6. **Maintenance**
 - 6.1 Fault finding during commissioning
 - 6.2 Fault finding after commissioning
 - 6.3 Servicing
 - 6.4 Routine maintenance
 - 6.5 Guarantee
 - 6.6 Customer comments
7. **Accessories**
 - 7.1 Scale card
 - 7.2 Tag information
 - 7.3 Alarms
 - 7.3.1 Alarm relay contacts
 - 7.3.2 Configuration and adjustment
 - 7.3.3 Alarm enable: $EnbL$
 - 7.3.4 Setpoint adjustment: SPt
 - 7.3.5 Alarm function: $HiLo$
 - 7.3.6 Alarm relay energised or de-energised in alarm condition: $ndnE$
 - 7.3.7 Hysteresis: $HSEr$
 - 7.3.8 Alarm delay: $dELR$
 - 7.3.9 Alarm silence time: SiL
 - 7.3.10 Flash display when alarm occurs: $FLASH$
 - 7.3.11 Latch alarm output: $LRtCH$
 - 7.3.12 Display colour in alarm condition: $CoLoR$
 - 7.3.13 Access setpoint in display mode: $RESP$
 - 7.3.14 Adjusting alarm setpoint from the display mode
 - 7.3.15 Display setpoints on the bargraph.
 - 7.4 4/20mA output and transmitter supply
 - 7.4.1 4/20mA loop design
 - 7.4.2 System design for powering a transmitter.
 - 7.4.3 Configuration and calibration
 - 7.4.4 4/20mA enable: $EnbL$
 - 7.4.5 Display which corresponds to 4mA output: 4000
 - 7.4.6 Display which corresponds to 20mA output: 20000
 - 7.4.7 RTD fault detection: $FRULt$
 - 7.5 Modbus RTU
 - 7.5.1 Configuration
 - 7.5.2 Modbus address: $Rddr$
 - 7.5.3 Modbus baud rate: $bRud$
 - 7.5.4 Odd, even or no parity: PRr
 - 7.5.5 Number of stop bits: $StoP$

1. DESCRIPTION

The Advisor A90 Universal Panel Meter is a multicolour five digit instrument, primarily intended for displaying a current, voltage or resistance analogue process signal in engineering units. The instrument can also display temperature directly from a resistance thermometer. The A90 is configurable on-site using the four front panel push buttons and an intuitive menu that can be protected by a security code to prevent accidental adjustment.

Housed in a robust Noryl enclosure with a toughened glass window, the A90 has IP66 front of panel protection and a gasket to seal the joint between the instrument and the mounting panel.

The A90 Process Panel Meter employs a novel technique that enables the display to be in any colour on a black background, readable in all conditions from total darkness to bright sunlight. The display intensity is fully adjustable to match other instruments and preserve operator's night time vision.

When fitted with optional alarms the display colour can be linked to the alarm status. For example, a green display could indicate normal operation, the display colour changing to red when a high alarm occurs and to blue when a low alarm occurs.

The instrument input type and range are selectable on-site and the meter display can be calibrated to show the engineering variable represented by the analogue input. The engineering units of measurement such as kg, gallons/hour or °C, can be printed on the slide-in scalecard.

One of the following input ranges may be selected:

Voltage input

0 to 100mV
0 to 1V
0 to 10V

Current input

4 to 20mA
0 to 50mA

Resistance thermometer input

2 or 3 wire connected PT100 resistance thermometer, or differential output from two PT100 resistance thermometers.

-200 to 850°C

There are two versions of the A90 Process Panel Meter, one powered by a low voltage dc supply and the other by a mains ac supply. The instrument power supply type is shown on the label adjacent to the power supply terminals 7 and 8.

dc powered model 10 to 36V

ac powered model 90 to 264V 47 - 63Hz

2. OPERATION

Fig 1 shows a simplified block diagram of the A90 Process Panel Meter. Field wiring terminals are the same for the low voltage dc powered version and for the mains ac powered version.

Terminals for the optional factory fitted alarms, 4/20mA output plus 24V transmitter supply and the Modbus interface are only fitted when the option is included.

Each time power is applied to the meter initialisation is performed during which all segments of the display are activated, after a few seconds the instrument enters the display mode using the calibration information stored in the instrument memory.

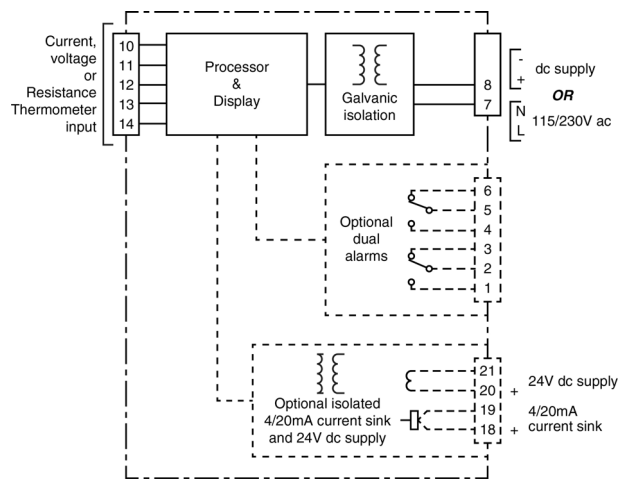



Fig 1 A90 panel meter block diagram

2.1 Controls



The Advisor A90 panel meter is controlled and calibrated via the four front panel push buttons located below the display. In the display mode i.e. when the meter is displaying a process variable, these push buttons have the following functions:

 While this button is pushed the meter will display the input as a percentage of the instrument span or, depending upon configuration, the analogue input in milliamps, volts or ohms.



When optional alarms are fitted and the latch function `LATCH` is enabled, pressing this button will de-latch the alarm output.



When the alarm silence time `SIL` is set to any value other than zero, operating this button clears the alarm for the configured silence time.



 While this button is pushed the meter will display the numerical value and analogue bargraph the meter has been calibrated to display with a minimum input i.e. 4mA or 0V. When released the normal display in engineering units will return.



If the hold function `Hold` is enabled, operating this button will cause the meter to display the lowest value since the hold function was last reset by operating the  and  buttons simultaneously.



 While this button is pushed the meter will display the numerical value and analogue bargraph the meter has been calibrated to display with a maximum input i.e. 20mA or 1V. When released the normal display in engineering units will return.



If the hold function `Hold` is enabled, operating this button will cause the meter to display the highest value since the hold function was last reset by operating the  and  buttons simultaneously.



 Unused unless tare function `TARE` is enabled. When tare function is enabled operating this button for less than 3 seconds toggles the meter display between the gross and net values. The 'T' annunciator is activated when the net display is shown. Operating the  button for more than 3 seconds tares the display by setting it to zero.



 +  When both buttons are operated simultaneously for more than 3 seconds slowly decreases display brilliance.

 +  When both buttons are operated simultaneously for more than 3 seconds slowly increases display brilliance.

 +  Shows firmware number followed by version.

 +  Direct access to the alarm setpoints when optional alarms are fitted to the meter and the `RESP` access setpoints in display mode function has been enabled.

 +  Resets the maximum and minimum hold memories when the `Hold` function is enabled.

 +  Access to configuration menu via optional security code.

3. APPLICATIONS

3.1 Power supply

3.1.1 Mains powered version

The mains powered version of the A90 panel mounting meter will operate from a wide range of voltage and frequency ac supplies.

Voltage	90 to 264V rms ac
Frequency	47 to 63Hz
Power	2.5W

The supply should be well regulated and free from transients.

3.1.2 DC powered version

The DC powered version of the A90 panel mounting meter is designed to be operated from a nominal 24V dc instrument power supply but, as shown below, will function with a wide range supply voltages.

Voltage	10 to 36V dc
Current	200mA at 10V 56mA at 36V

3.2 Signal inputs

The A90 panel meter can measure current and voltage process signals and display them in meaningful engineering units. The meter can also display temperature in a variety of formats from a Pt100 resistance thermometer primary element. Selection of the input type is made within the configuration menu which is described in section 5 of this manual. Input terminals also vary for different inputs as shown in Fig 6.

3.2.1 Current input

The A90 panel meter can measure and display in engineering units any process signal represented by an analogue linear or square law current such as a 4/20mA process signal. The A90 has two current input ranges 4-20mA and 0-50mA dc.

The current input terminals 13 and 14 are galvanically isolated from the A90 meter power supply and all other outputs which allows the A90 meter to measure the current in any process loop without affecting the accuracy of the loop. When connected in series with a current loop the A90 panel meter introduces the following voltage drops:

At 20mA	1.0V
At 50mA	1.5V

Fig 2 shows how the A90 panel meter should be connected to measure a process current.

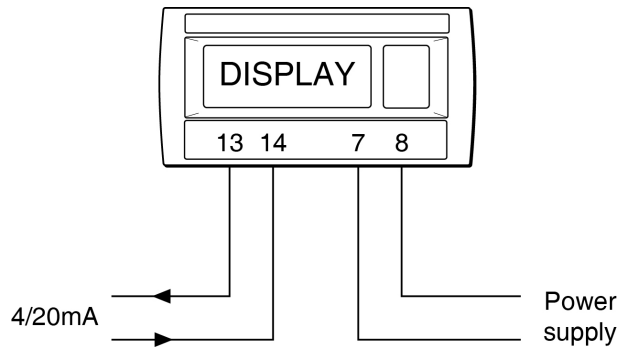

Fig 2 A90 Process panel meter measuring current

3.2.2 Voltage input

The A90 panel meter can measure and display in engineering panel units any linear process signal represented by an analogue voltage such as a 0 to 1V signal. The voltage input terminals 11, 12 and 13 are galvanically isolated from the A90 meter power supply and all other outputs. There are three dc voltage input ranges:

	Terminals	Input resistance
0 to 0.1V	13 (0V) and 12 (+ve)	5MΩ
0 to 1.0V	13 (0V) and 12 (+ve)	5MΩ
0 to 10V	13 (0V) and 11 (+ve)	1MΩ

The input resistance of all the voltage inputs is high allowing the A90 meter to measure any process voltage signal without loading it and changing the value. Fig 3 shows how the A90 panel meter should be connected to measure a process voltage.

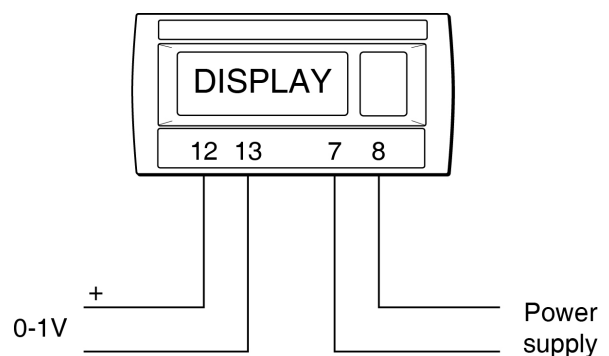

Fig 3 A90 Process panel meter measuring voltage

3.2.3 Resistance thermometer input

The A90 panel meter can measure the resistance of a single Pt100 BS EN 60751 platinum resistance thermometer and display the corresponding temperature in a variety of units including °C and °F. The resistance thermometer may be connected to the meter via two or three wires. The differential output of two resistance thermometers can also be measured and displayed.

Fig 4 shows the connections for two and three wire resistance thermometers and Fig 5 the connections for differential measurements.

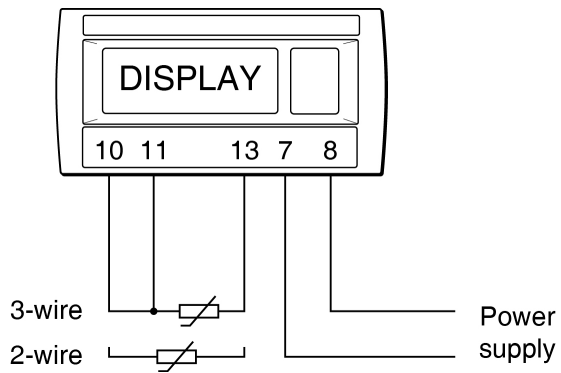

Fig 4 connections for a 2 or 3 wire resistance thermometer

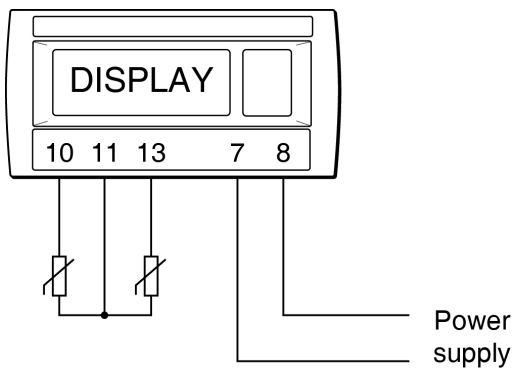

Fig 5 Connections for differential resistance thermometer measurements.

4. INSTALLATION

4.1 Location

The A90 panel meter has a robust glass reinforced modified PPO Noryl enclosure with a toughened glass window. The front of the meter has IP66 protection and a gasket seals the joint between the instrument enclosure and the panel. The instrument has IP20 rear protection which can be increased to IP66 with a BA495 stainless steel rear cover and sealing kit. This has two M20 entries for cable glands and allows the A90 to be installed in open panels.

The meter may be installed in any panel providing that the operating temperature is between -40°C and +55°C.

The A90 panel meter complies with the Low Voltage Directive 2014/35/EU and has the following isolation between circuits:

AC powered model supply input	3kV rms
DC powered model supply input	1.5kV
Optional alarm contacts	4kV rms
All other circuits	500V rms

The A90 panel meter does not require an earth connection.

Fig 6 shows the overall dimensions of the instrument together with the recommended panel cut-out dimensions to achieve an IP66 seal between the instrument enclosure and the instrument panel.

Although the meter front panel provides IP66 protection it should be shielded from continuous direct sunlight and severe weather conditions.

Fig 6 show the overall dimensions of the indicators together with the recommended panel enclosure cut-out dimensions.

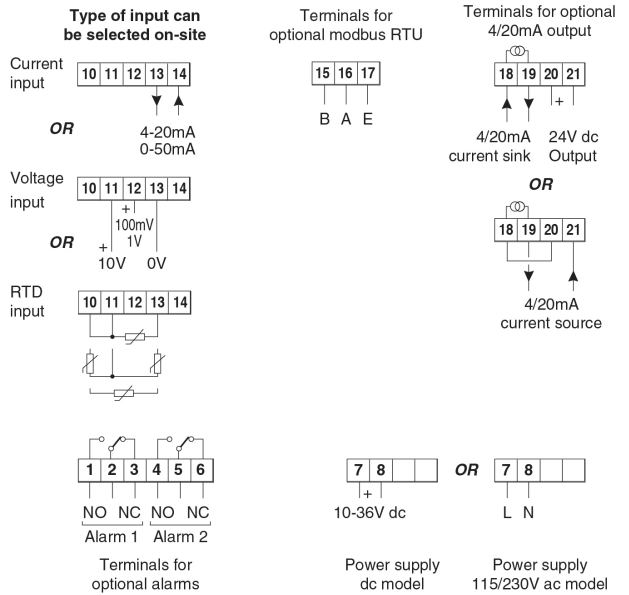
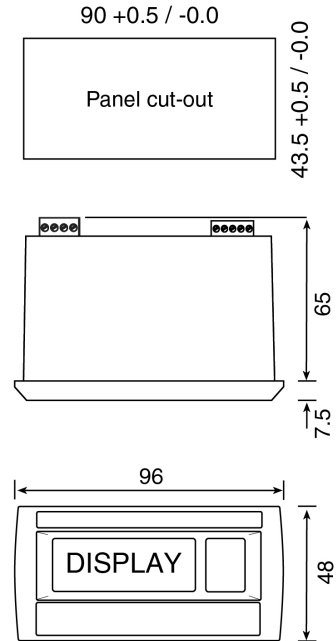

Fig 6 A90 meter dimensions and terminals

Panel wiring should be supported to prevent vibration causing damage to the wiring or terminals.

4.2 EMC

The A90 panel meter complies with the requirements of the European EMC Directive 2014/30/EU. For specified immunity all signal wiring should be screened with the screens earthed at one point. Voltage and current input wiring should be in twisted pairs.

4.3 Installation Procedure

- To achieve an IP66 seal between the instrument enclosure and the instrument panel, the panel aperture should have the recommended dimensions specified in Fig 6.
- Slide the gasket over the body of the meter before inserting the instrument into the panel aperture.
- Firstly ensure that both the panel mounting clamps are closed by turning the knurled screws fully anti clockwise until the two pips in the clamp foot align with holes in the clamp body.
- Place a clamp in the recess on each side of the meter, pulling gently to slide it onto the dovetail as shown in Fig 7. Push the knurled screw slightly forward to engage the thread and tighten by turning clockwise until it is just finger tight. When both clamps are fitted ensure that the gasket behind the front panel bezel is correctly positioned before fully tightening the clamps to secure the instrument. The maximum recommended clamp tightening torque is 22cNm (1.95 lbf in) which is approximately equivalent to finger-tight plus one half turn. **Do not over tighten.**
- Connect the panel wiring to the rear terminal blocks as shown in Fig 6. The terminals may be removed from the instrument by pulling.

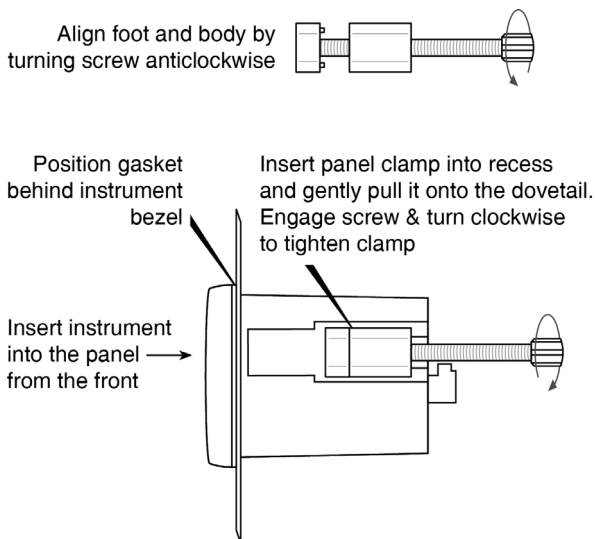

Fig 7 Fitting panel mounting clamps

4.4 Scale card

The meter's units of measurement may be shown on a scale card visible through a window at the right hand end of the display. The scale card is mounted on a flexible strip that is inserted into a slot at the rear of the instrument as shown in Fig 8. Thus the scale card can easily be changed without removing the meter from the panel or opening the instrument enclosure.

New meters are supplied with a printed scale card showing the requested units of measurement. If this information is not supplied when the meter is ordered a blank card will be fitted.

A pack of self-adhesive scale cards printed with common units of measurement is available as an accessory from BEKA associates. Custom printed scale cards can also be supplied.

To change a scale card, unclip the protruding end of the flexible strip by gently pushing it upwards and pulling it out of the enclosure. Peel the existing scale card from the flexible strip and replace it with a new printed card, which should be aligned as shown below. Do not fit a new scale card on top of an existing card.

Install the new scale card by gently pushing the flexible strip into the slot at the rear of the indicator, when it reaches the internal end-stop secure it by pushing the end of the flexible strip downwards so that the tapered section is held by the rear panel.

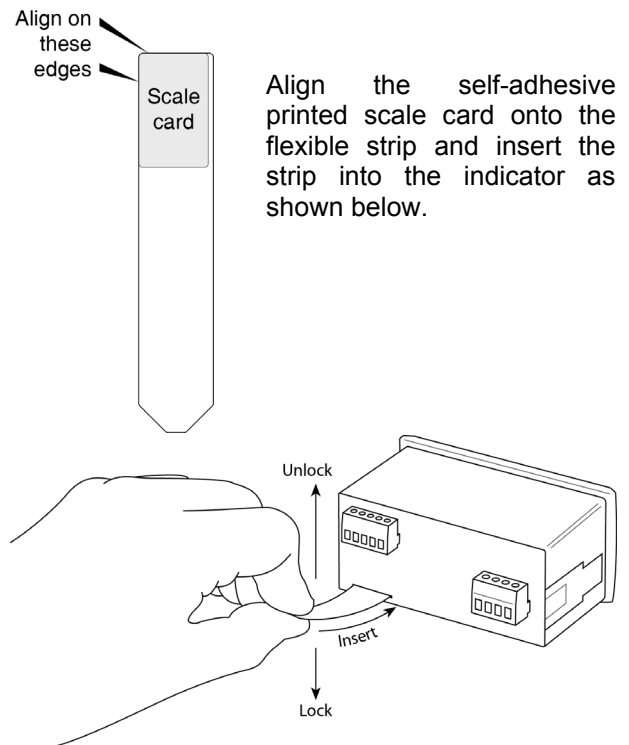













Fig 8 Inserting flexible strip carrying scale card into slot at the rear of the A90 meter.



5. CONFIGURATION AND CALIBRATION

The A90 process panel meter is configured and calibrated via the four front panel push buttons. All the configuration functions are contained in an easy to use intuitive menu that is shown diagrammatically in Fig 9.

Each menu function is summarised in section 5.1 and includes a reference to more detailed information. When the meter is fitted with alarms additional functions are added to the menu which are described in section 7.3. Similarly when a 4/20mA output is fitted, additional functions appear in the configuration menu which are described in section 7.4.

Throughout this manual push buttons are shown as , ,  and  and legends displayed by the meter are shown in a seven segment font exactly as displayed e.g. \overline{LRL} and $R\overline{LR}2$.

Access to the configuration menu is obtained by operating the  and  push buttons simultaneously. If the meter security code is set to the default $\overline{0000}$ the first parameter \overline{INPUL} will be displayed. If a security code other than the default code $\overline{0000}$ has already been entered, the meter will display \overline{CodE} . Pressing the  button will clear this prompt allowing each digit of the code to be entered using the  or  push button to adjust the flashing digit and the  button to move control to the next digit. When the correct four digit code has been entered, pressing  will cause the first parameter \overline{INPUL} to be displayed. If the code is incorrect, or a button is not pressed within twenty seconds, the meter will automatically return to the display mode.

Once within the configuration menu the required parameter can be reached by scrolling through the menu using the  or  push button as shown in Fig 9. When returning to the display mode following reconfiguration or recalibration, the meter will display \overline{dRRR} followed by $\overline{5RUE}$ while the new information is stored in permanent memory.

CAUTION

When making adjustments in the configuration menu, if the interval between pressing any button exceeds one minute, the A90 meter will automatically return to its display mode and any configuration changes will not be saved.

All new meters are supplied configured and calibrated as requested at the time of ordering. If calibration is not requested, meters will be configured as follows:

Input \overline{INPUL}	4-20
Function \overline{FUNC}	5Ed
Loop break detection \overline{LFLa}	aFF
Resolution \overline{RESn}	1
Decimal point \overline{dP}	000.00
Display at 4mA \overline{ZERa}	0.00
Display at 20mA $\overline{5PRn}$	100.00
Bargraph \overline{TYPE}	LEFt
Bargraph start \overline{bRRLo}	000
Bargraph finish \overline{bRRHi}	100.00
 button in display mode $\overline{u--P}$	Pt
Tare $\overline{tRR-E}$	aFF
Max and min hold \overline{HOLD}	aFF
Display colour \overline{Color}	green P5Et.4
Access code \overline{CodE}	0000

Default configuration can easily be changed on-site.

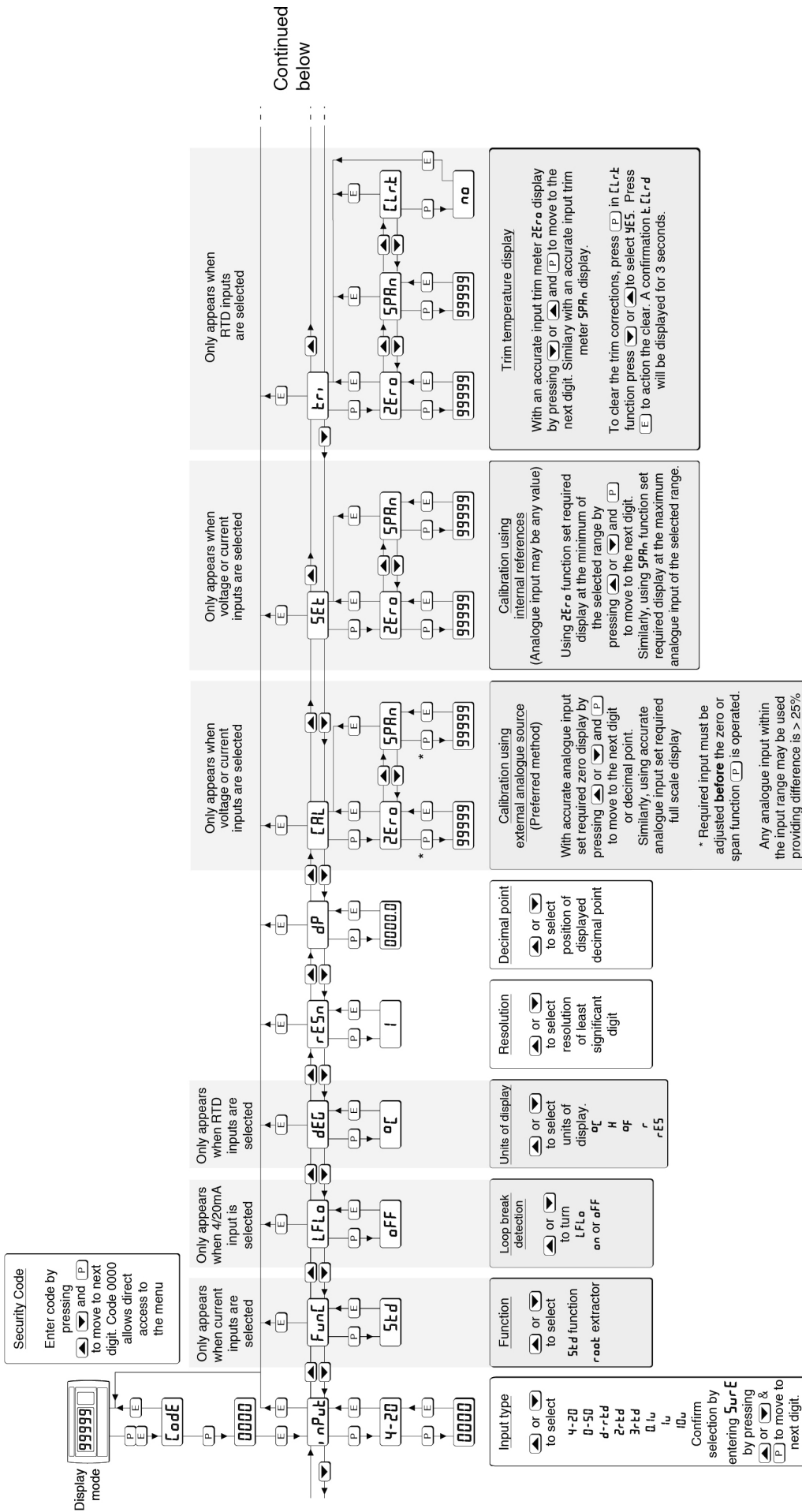

Fig 9 Configuration menu

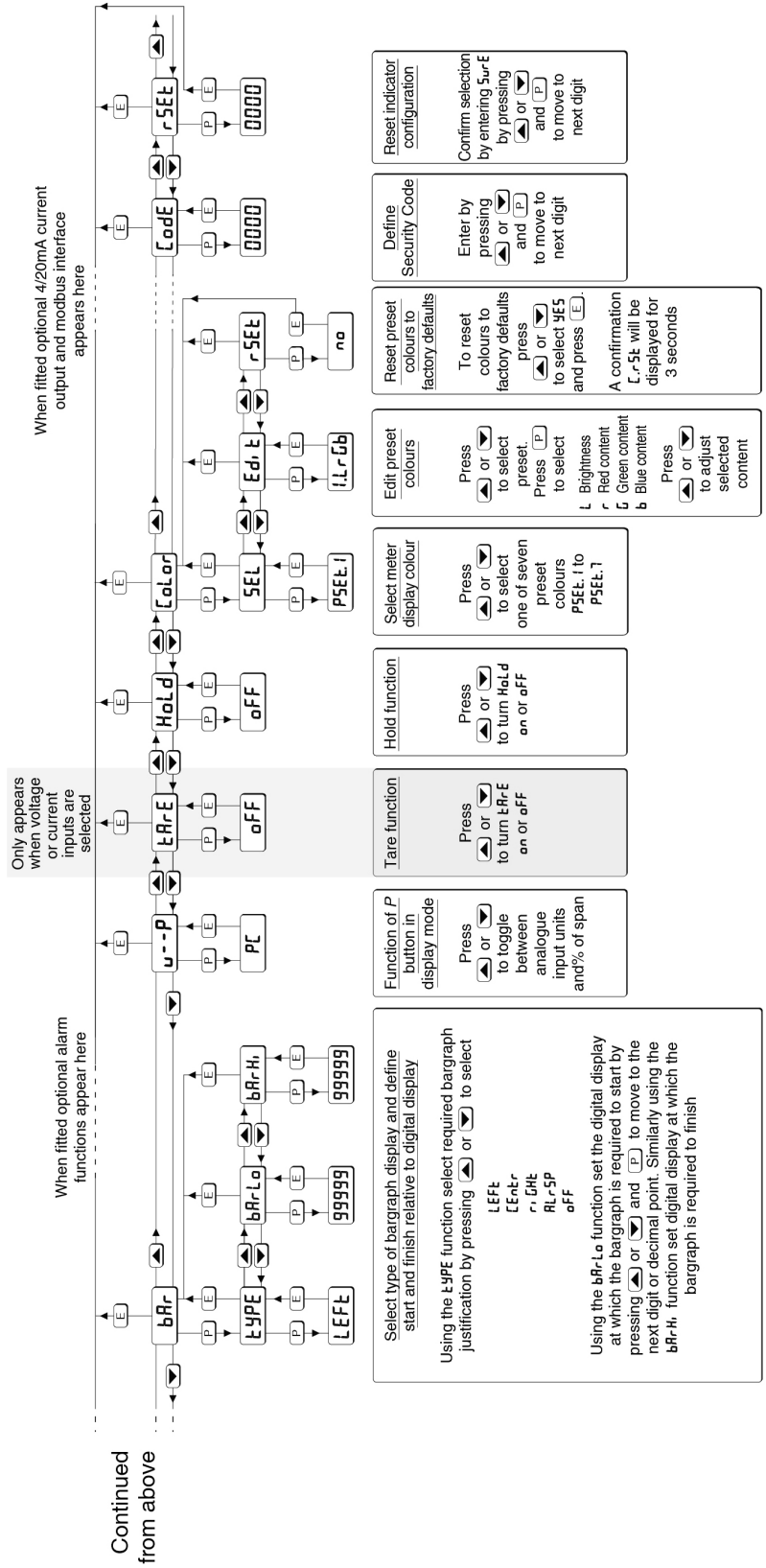

Fig 9 Configuration menu

5.1 Summary of configuration functions

This section summarises each of the main configuration functions and includes a cross reference to a more detailed description. Fig 9 illustrates the location of each function within the configuration menu. The optional factory fitted alarms and 4/20mA output are described separately in sections 7.3 and 7.4 of this manual.

Display	Summary of function
INP	<p>Input type Defines the A90 meter's input type and range. One of eight inputs may be selected. To prevent accidental use the selection must be confirmed by entering 5urE before it will be executed. See section 5.2</p>
FunC	<p>Meter function <i>only for current inputs</i> Defines the relationship between the input current and the meter display. May be set to: 5td Standard linear relationship rsot Square root extraction See section 5.3</p>
LFLo	<p>Loop break detection <i>only for 4/20mA input.</i> Enables detection of 4/20mA input current loss to be turned on or off. See section 5.4</p>
dEG	<p>Units of temperature <i>only for RTD inputs.</i> Defines the units of display when a resistance thermometer input is selected in the INP function. One of five units may be selected. See section 5.5</p>
rESn	<p>Display resolution Defines the resolution of the least significant display digit. May be set to 1, 2, 5 or 10 digits. See section 5.6</p>

Display	Summary of function
dP	<p>Decimal point Positions a fixed decimal point between any of the digits in the A90 meter display, or activates automatic decimal point positioning to provide maximum display resolution. Alternatively the meter display may be shown without a decimal point. The position of the displayed decimal point does not affect the position of the decimal point in any of the other configuration menus. Therefore when adjusting the CRl, 5Et or bRr functions, the decimal point position within the function should normally be set to the same as that selected for the dP function. See section 5.7</p>
CRl	<p>Calibration of the digital display using an external source <i>only for current or voltage inputs.</i> Enables the zero and span of the meter to be adjusted using an external current or voltage source such as a calibrator. When used with an accurate traceable source this is the preferred method of calibration. See section 5.8</p>
5Et	<p>Calibration of digital display using internal reference <i>only for current or voltage inputs.</i> Enables the zero and span of the meter to be adjusted without the need for an accurate input current or disconnection from the current loop or voltage input. See section 5.9</p>
tr	<p>Trim temperature display <i>only for RTD inputs.</i> Enables the displayed temperature to be trimmed to compensate for inaccuracies resulting from unbalanced cable resistance and primary element inaccuracies. See section 5.10</p>
bRr	<p>Bargraph format and calibration The bargraph may be configured to start from left, right or centre of the display, or it may be disabled. When optional alarms are fitted it can also display both alarm setpoints and the measured value. The bargraph may be calibrated to start and finish at any value within the meter's calibrated digital display. See section 5.11</p>

Display	Summary of function
---------	---------------------

u - - P	Function of  push button in display mode.
----------------	---

The meter may be configured to display the analogue input signal, or the analogue input as a percentage of the meter span when the  push button is operated in the display mode.

When optional alarms are fitted the  push button is also used for the control of the silence and latching functions.





See section 5.12

tRrE	Tare function
-------------	----------------------

When enabled the tare function sets the meter display to zero when the  push button is operated in the display mode.

See section 5.13

HoLd	Maximum and minimum hold function
-------------	--

When enabled, the A90 meter will store the maximum and minimum readings which can then be accessed from the display mode by pressing the  or  buttons respectively. Operating the  and  buttons simultaneously in the display mode resets both the minimum and maximum hold values.

See section 5.14

Display	Summary of function
---------	---------------------

CoLoR	Set meter display colour Contains three sub-functions which enable the colour of the meter display to be selected.
--------------	--

5EL Select one of 7 preset colours

Ed, t Adjust preset colours

r5Et Reset presets to factory defaults

See section 5.15

CoDE	Security code Defines a four digit alphanumeric code that must be entered to gain access to the configuration menu. Default code 0000 disables this security function and allows unrestricted access to all configuration functions.
-------------	---

See section 5.16

r5Et	Reset to factory defaults Returns the A90 panel meter to the factory defaults shown in section 5. which vary depending on the configured type of input. To prevent accidental use the request must be confirmed by entering 5urE before the reset will be executed.
-------------	--

See section 5.17

5.2 Input type: $INPUL$

This configuration function defines the A90 panel meter's input type and range. One of eight inputs may be selected.

Display	Input
4-20	4/20mA
0-50	0/50mA
d-rtd	Differential RTD
2-rtd	2 wire RTD
3-rtd	3 wire RTD
0.1v	0 to 0.1V
1v	0 to 1v
10v	0 to 10V

To prevent the input being changed accidentally, after selection the change must be confirmed by entering $5UR$ before the change will be executed.

To reveal the existing meter input select $INPUL$ from the configuration menu and press P . If the input type and range is set as required, press E to return to the configuration menu, or press the \downarrow or \uparrow button to select the required input.

When the required input has been selected pressing P will result in 0000 being displayed with the first digit flashing. To confirm the instruction $5UR$ should be entered. Using the \downarrow or \uparrow button set the first flashing digit to 5 and press P which will transfer control to the second digit which should be set to v . When $5UR$ has been entered pressing the E button will change the input configuration and return the meter to the input prompt in the configuration menu.

5.3 Meter Function: FUN

This configuration function only appears in the menu when the A90 panel meter is configured for a current input. It enables a square root extractor which allows the meter to display the output from a differential pressure flowmeter in linear engineering units. One of two options may be selected:

5td	Standard linear relationship
root	Square root extraction

To reveal the existing setting select FUN from the configuration menu and press P . If set as required, press E to return to the configuration menu, or press the \downarrow or \uparrow button to toggle the display to the required configuration followed by the E button to return to the configuration menu.

5.4 Loop break detection: LFL

This function only appears in the menu when the A90 panel meter is configured for a 4/20mA current input. To check or change the function's status, select LFL in the configuration menu and press P to reveal the current setting. Pressing the \downarrow or \uparrow button will toggle the setting between on and off . When set as required, press E to return to the LFL prompt in the configuration menu.

When on is selected, an input current below 3.6mA, which is the NAMUR NE43 recommended sensor fault current threshold, will activate loop break detection and the A90 will display a flashing LFL . When the input current rises above 3.6mA loop break detection will be immediately deactivated.

5.4.1 Operation with optional alarm outputs

When the A90 meter is fitted with optional alarms, activation of the loop break detection will:

De energise both alarm output relays

Display flashing LFL in selected non alarm colour.

5.4.2 Operation with optional 4/20mA output

When the A90 meter is fitted with an optional 4/20mA output, activation of the loop break detection will:

Set output current to 3.5mA

Display flashing LFL

5.5 Units of temperature: dEU

This configuration function only appears in menu when the A90 panel meter is configured for a resistance thermometer input. One of the following five units may be selected:

Display	Units of display
$^{\circ}C$	Degree Celsius
K	Kelvin
$^{\circ}F$	Degree Fahrenheit
r	Degree Rankine
rE5	Resistance in ohms

To reveal the existing units of display select dEU from the configuration menu and press P . If set as required, press E to return to the configuration menu, or press the \downarrow or \uparrow button to select the required units followed by the E button to return to the configuration menu.

5.6 Display resolution: $rE5n$

This function defines the resolution of the least significant display digit. Decreasing the display resolution can improve the readability of a noisy signal. One of 4 resolutions may be selected:

1, 2, 5 or 10 digits

To check or adjust the resolution select $rE5n$ from the configuration menu and press P which will reveal the current setting. To change the resolution press the V or A button to select the required number of digits, followed by the E button to enter the selection and return to the configuration menu.

5.7 Decimal point: dP

This function enables a fixed decimal point to be positioned between any of the five display digits, or for the decimal point to be automatically positioned to provide maximum display resolution. Alternatively the display may be without a decimal point.

To position the decimal point select dP from the configuration menu and press P . The decimal point can be moved by pressing the V or A push button. If a decimal point is not required it should be positioned beyond the most or least significant digit. If maximum display resolution is required auto should be selected by repeatedly operating the V or A button until $RdE0$ is displayed.

When the decimal point has been positioned as required or $RdE0$ has been selected, press the E button to enter the selection and return to the configuration menu.

The position of the displayed decimal point does not affect the position of the decimal point in any of the other configuration menus. Therefore when adjusting the LRl , SEt or bRr functions, the decimal point position within the function should normally be set to the same as that selected in this dP function.

5.8 Calibration of the digital display using an external source: LRl

This function, which is only included in the configuration menu when the meter has been configured for a current or voltage input, enables the zero and span of the A90 panel meter to be adjusted using an external calibrated voltage or current source. When used with an accurate traceable source, such as a calibrator, this is the preferred method of calibration.

Input range	Zero	Span
4-20mA	4mA	20mA
0-50mA	0mA	50mA
0.1V	0V	0.1V
1V	0V	1v
10V	0V	10V

To calibrate the meter select LRl from the configuration menu and press P . The meter will display $ZEro$ which is a request for the zero input current or voltage. Adjust the external calibrator to the zero input current or voltage and again press P which will reveal the current zero A90 meter display with one digit flashing. The flashing digit of the meter display can be changed by pressing the V or A button. When set as required pressing P will transfer control to the next digit. When all the digits have been adjusted, pressing P will transfer control to the decimal point which should normally be positioned in the same place defined in the dP function. Finally press E to enter the new meter zero display and return to the $ZEro$ prompt.

Pressing the A button will cause the meter to display $SPRn$ which is a request for the span input current or voltage. Adjust the external calibrator to span input and again press P which will reveal the existing span meter display with one digit flashing. The flashing digit can be changed by pressing the V or A button. When set as required pressing P will transfer control to the next digit. When all the digits have been adjusted, pressing P will transfer control to the decimal point which should normally be positioned in the same place defined in the dP function. When set as required press E to enter the new span and return to the $SPRn$ prompt. Finally press E again to return to the configuration menu.

Notes:

- The A90 meter input current or voltage must be adjusted to the required value **before** the $ZEro$ and $SPRn$ functions are entered by pressing the P button.
- Meters may be calibrated at current and voltage inputs other than the values shown above, providing the difference between the two is greater than 25% of the meter input range. If these conditions are not complied with, the meter will display $FR.L$ and the calibration will be terminated. If the zero input is greater than the span input the meter will be reverse acting i.e. an increasing input will cause the display to decrease.

5.9 Calibration of the digital display using an internal reference: 5E£

This function, which is only included in the configuration menu when the meter is configured for a current or voltage input, enables the meter to be calibrated without the need for an accurate external current source and without the meter input terminals being disconnected.

The meter's internal reference is used to simulate calibration inputs, therefore the actual meter input does not have to be known during calibration. Although not traceable or as accurate as the £RL function, this method of calibration is acceptable for many industrial applications. The Zero and Span calibration inputs are shown below.

Input range	Zero	Span
4-20mA	4mA	20mA
0-50mA	0mA	50mA
0.1V	0V	0.1V
1V	0V	1v
10V	0V	10V

To calibrate the A90 panel meter display select 5E£ from the configuration menu and press **[P]**. The meter will display 2E£, pressing **[P]** again will reveal the current display at zero input with one digit flashing. The flashing digit can be adjusted by pressing the **[▼]** or **[▲]** button. When set as required pressing **[P]** will transfer control to the next digit. When all the digits have been adjusted, pressing **[P]** will transfer control to the decimal point which should normally be positioned in the same place defined in the dP function. Finally press **[E]** to enter the new meter zero display and return to the 2E£ prompt.

To adjust the display at the span input, press the **[▲]** button which will cause the meter to display 5PRn pressing **[P]** will then reveal the meter's existing span display with one digit flashing. The flashing digit can be adjusted by pressing the **[▼]** or **[▲]** button, when the flashing digit is correct pressing **[P]** will transfer control to the next digit. When all the digits have been adjusted, pressing **[P]** will transfer control to the decimal point which should normally be positioned in the same place defined in the dP function. When set as required press **[E]** twice to return to the 5E£ prompt in the configuration menu.

5.10 Trim temperature display: £r,

This function only appears in the configuration menu when the A90 meter has been configured for a resistance thermometer input.

The trim function enables the zero and span of the temperature display to be adjusted to compensate for the cable resistance of a two wire connected RTD and the cable imbalance of a three wire connected RTD. Compensation can also be applied for primary element interchangeability errors. The £r, function also contains a clear trim function £Lr£ which removes any zero and span trim that has been applied and returns the A90 meter's temperature display calibration to the Pt100 figures specified in IEC 60751.

To compensate for cable imbalance connect a calibrator with resistance equivalent to the required lower A90 meter temperature reading in place of the resistance thermometer. *Please see caution at the end of this section.* Select £r, from the meter configuration menu and press the **[P]** button which will result in the meter displaying 2E£. Pressing **[P]** again will cause the lower meter reading to be displayed with one digit flashing.

The A90 meter can now be trimmed to display the correct temperature equivalent to the calibrator resistance. Pressing the **[▼]** or **[▲]** button will adjust the flashing digit and the **[P]** button will transfer control to the next digit. When the A90 meter display is correct, press **[E]** to return to the 2E£ prompt.

To trim the upper A90 meter reading first set the calibrator to the resistance equivalent to the required upper A90 meter temperature reading. *Please see caution at the end of this section.* Select 5PRn by pressing the **[▼]** or **[▲]** button followed by **[P]**. The upper reading can then be trimmed in the same way as the lower reading. When the A90 meter upper display is correct press **[E]** to return to the 5PRn prompt.

The sub-function £Lr£ removes any zero and span trim that has been applied and returns the A90 meter's temperature display calibration to the Pt100 figures specified in IEC 60751. To clear trim select £r, from the A90 meter configuration menu and press the **[P]** button which results in the meter displaying 2E£. Using the **[▼]** or **[▲]** button select £Lr£ and press **[P]** which will result in n£ being displayed, change this to 4E5 using the **[▼]** or **[▲]** button and press **[E]**. The meter will display £.£Lr£ while the trim is being removed and will then return to the display mode.

Note: The calibrator connected to the A90 input must be set to the required input temperature or resistance **before** the 2E£ or 5PRn functions are entered by operating the **[P]** button. Failure to do this will result in trim errors.

5.11 Bargraph format and calibration: bRr

In addition to the five digit numerical display the A90 panel meter has a 31 segment analogue bargraph which may be configured to start from the left, centre or right hand end and to represent any part of the meter's numerical display range.

To configure the bargraph select bRr from the configuration menu and press the **[P]** button. The meter will display **LYPE**, pressing **[P]** again will reveal the existing bargraph justification which can be changed to one of the following four or five options using the **[V]** or **[A]** button:

	Bargraph starts from
LEFL	Left end of display
CENTR	Centre of display
RIGHT	Right end of display
ALSP	Only with alarms – see section 7.3.15
OFF	Bargraph disabled

When set as required press **[E]** to return to the **LYPE** sub-function prompt.

The panel meter's digital display at which the bargraph starts is defined by the bRrLo sub-function which is accessed from the **LYPE** prompt by pressing **[V]** or **[A]** buttons. When bRrLo is displayed operating the **[P]** button will reveal the current meter display at which the bargraph starts. The flashing digit can be adjusted by pressing the **[V]** or **[A]** button, when set as required pressing **[P]** will transfer control to the next digit. When all the digits have been adjusted, pressing **[P]** will transfer control to the decimal point which should normally be positioned in the same place defined in the dP function. When set as required press **[E]** to return to the bRrLo prompt from which bRrHi, which defines the finishing point of the bargraph can be selected by pressing the **[V]** or **[A]** buttons. bRrHi is adjusted in the same way as bRrLo. When both are set as required, pressing **[E]** twice will return the display to the bRr prompt in the configuration menu.

Note: bRrLo must be set lower than bRrHi, incorrect setting is indicated by the bargraph scale flashing with all the bargraph segments activated.

5.12 Function of the **[P]** push button: u - - P

The A90 panel meter can be configured to display the meter's analogue input, or the displayed value as a percentage of the difference between the zero and span displayed values when the **[P]** button is operated in the display mode.

The analogue meter input is displayed in volts, milliamps or ohms depending upon how the meter input has been configured.

To check or change the function of the **[P]** push button select u - - P from the configuration menu

and press **[P]** to reveal the current setting. Pressing the **[V]** or **[A]** button will toggle the setting between the analogue input **u - - P** and the percentage display **PC**. When set as required press **[E]** to return to the u - - P prompt in the configuration menu.

When optional alarms are fitted the **[P]** push button is also used for the control of the silence and latching functions.

5.13 Tare function: tRrE

The Tare function, which is only included in the configuration menu when the meter is configured for a current or voltage input, is primarily intended for use with a weighing system. When the panel meter is in the display mode and the tare function is activated, pressing the **[E]** button for more than three seconds will cause the meter to briefly display **tRrE**, zero the meter's digital display and activate the tare annunciator 'T'. The bargraph remains linked to the digital display when the tare function is activated. Subsequent operation of the **[E]** push button for less than 3 seconds will return the panel meter to the gross display and deactivate the tare annunciator.

To check or change the tare function select tRrE in the configuration menu and press **[P]** to reveal the current setting. Pressing the **[V]** or **[A]** button will toggle the setting between **on** and **OFF**. When set as required press **[E]** to return to the tRrE prompt in the configuration menu.

5.14 Maximum and minimum hold function: HoLd

When enabled, the panel meter will store the maximum and minimum display readings since the maximum and minimum stores were last reset which is accomplished by operating the **[V]** and **[A]** buttons simultaneously in the display mode. The minimum and maximum values can be viewed at any time when the meter is in the display mode by operating the **[V]** or **[A]** push buttons respectively.

To reveal the existing setting select HoLd from the configuration menu and press **[P]**. If set as required, press **[E]** to return to the configuration menu, or press the **[V]** or **[A]** button to toggle the display to the required configuration **on** or **OFF** followed by the **[E]** button to return to the configuration menu.

5.15 Select meter display colour: CoLor

The digital display, bargraph and the display annunciators can be shown in any colour. To simplify configuration the red, green and blue content of seven preset colours identified **P5E1** to **P5E7** can be independently adjusted in this

function allowing the meter display colour to be matched to other instruments or annunciators mounted on the same panel.

A sub-function included within the function resets all the preset colours to the factory defaults which are:

P5E1.1	Red
P5E1.2	Orange
P5E1.3	Light green
P5E1.4	Green
P5E1.5	Blue
P5E1.6	Purple
P5E1.7	White

To select one of the factory default display colours select CALOR from the configuration menu and press P . The meter will display 5EL, pressing P again will reveal the existing preset display colour which can be changed to one of the other six preset colours using the V or A button. When set as required, press E twice to return to the CALOR prompt in the configuration menu.

If none of the default colours is suitable, each preset can be adjusted in the Edt sub-function which enables the red, green and blue content and the overall brilliance of each preset to be adjusted. To adjust a preset colour select CALOR from the configuration menu and press P . The meter will display 5EL. Using the V or A button select the edit sub-menu Edt and press P which will reveal the current selected preset colour as shown below.

5.LrCb

with the preset number flashing.

The preset colour to be adjusted can be selected using the V or A button. When selected pressing P will move control between the four variables, each of which can be increased with the A button and decreased with the V button. When set as required, press E twice to return to the CALOR prompt in the configuration menu.

The CALOR function contains a reset sub-function which returns all of the seven preset to their factory preset colours without changing any of the other meter configurations. To reset the preset colours to the factory defaults select CALOR from the configuration menu and press P . The meter will display 5EL. Using the V or A button select the reset sub-menu r5Et and press P . The meter will show na which should be changed to 4E5 using the V or A button followed by E which will reset all the preset colours. The meter will display r5Et while resetting and then return to the CALOR prompt in the configuration menu.

The configuration menu for the optional alarms allows any of the seven preset colours to be selected to indicate that an alarm condition has

occurred. For example, the display could be green in normal operation changing to red to indicate that a high alarm has occurred and to blue if a low alarm has occurred. See section 7.3.12

5.16 Security code: CodE

Access to the meter configuration menu may be protected by a four digit security code which must be entered to gain access. New instruments are configured with the default security code 0000 which allows unrestricted access to all configuration functions.

To enter a new security code select CodE from the configuration menu and press P which will cause the meter to display the existing security code with one digit flashing. The flashing digit can be adjusted using the V or A button, when set as required operating the P button will transfer control to the next digit. When all the digits have been adjusted press E to return to the CodE prompt in the configuration menu. The revised security code will be activated when the meter is returned to the display mode. Please contact BEKA associates sales department if the security code is lost.

5.17 Reset to factory defaults: r5Et

This function enables the A90 panel meter to be quickly returned to the factory default configurations shown in sections 5. Factory defaults vary depending on how the A90 meter's type of input has been configured.

To reset the meter select r5Et from the configuration menu and press P , the meter will display 0000 with one digit flashing which is a request to confirm the instruction by entering 5urE. Using the V or A button adjust the flashing digit to 5 and press P to transfer control to the second digit which should be set to u . When 5urE has been entered pressing the E button will reset the meter configuration to the factory defaults and return the instrument to the display mode.

5.18 Under and over-range

If the digital display range is exceeded, all the decimal points will flash as shown below:

Underrange	- 9.9.9.9
Overrange	9.9.9.9

Under or overrange of the bargraph is indicated by a flashing arrow at the appropriate end of the bargraph.

6. MAINTENANCE

CAUTION

The mains powered model will have 230V ac on rear terminals. Isolate power supply before starting maintenance.

Optional alarms on both the mains powered and the dc powered model may have 230V ac on optional alarm contacts. Isolate supply to alarm contacts before starting maintenance.

6.1 Fault finding during commissioning

If a meter fails to function during commissioning the following procedure should be followed:

Symptom	Cause	Solution
No display	Incorrect power supply wiring Brightness reduced too far.	Check wiring Press ⏏ plus ▲ to increase display brightness.
Meter has a display but readings are incorrect.	Input connected to wrong terminals. Meter configured for the wrong input.	Check input is connected to correct terminals & polarity is correct. Check meter input configuration.
All decimal points flashing.	Underrange if -ve sign displayed or overrange.	Recalibrate the meter.
Unstable display	Noisy input signal.	Eliminate source of noise and/or decrease meter resolution. Turn off Auto in the decimal point position function dP .
Meter flashing LFLo	4/20mA loop break detection has been activated.	Increase input above 3.6mA. Turn off loop break detection in the LFLo function.
Unable to enter configuration menu.	Incorrect security code entered.	Enter correct security code, or contact BEKA if the code has been lost.

6.2 Fault finding after commissioning

ENSURE PLANT SAFETY BEFORE STARTING MAINTENANCE

If an A90 panel meter fails after it has been functioning correctly follow the procedure shown in section 6.1. If this does not reveal the cause of the fault, please contact one of our technical application engineers for advice,

6.3 Servicing

All A90 meters are interchangeable providing the replacement has the same supply voltage and optional factory fitted accessories. A single spare instrument may quickly be recalibrated to replace any instrument that is damaged or fails. No attempt should be made to repair instruments at component level.

We recommend that faulty instruments are returned to BEKA associates or to your local BEKA agent for repair.

6.4 Routine maintenance

The mechanical condition of the instrument and electrical calibration should be regularly checked. The interval between inspections depends upon environmental conditions.

6.5 Guarantee

A90 panel meters which fail within the guarantee period should be returned to BEKA associates or our local agent. It is helpful if a brief description of the fault symptoms is provided.

6.6 Customer comments

BEKA associates is always pleased to receive comments from customers about our products and services. All communications are acknowledged and whenever possible, suggestions are implemented.

7. ACCESSORIES

7.1 Scale card

The A90 panel meter has a window on the right hand side of the display through which to view a scale card showing the units of measurement such as °C, mbar or rpm. New meters are fitted with a scale card showing the units of measurement specified when the meter was ordered, if the units are not specified a blank scale card will be fitted.

A pack of scale cards pre-printed with common units of measurement is available as an accessory. These can easily be fitted to the A90 meter without opening the instrument enclosure or removing it from the panel, See section 4.4 of this instruction manual.

Custom scale cards for applications requiring less common units of measurement are also available.

7.2 Tag information

New meters can be supplied with tag or application information printed onto the rear panel adjacent to the terminals, This tag information is not visible from the front of the instrument after installation.

7.3 Alarms

CAUTION

These alarm outputs should not be used for critical safety applications such as an emergency shut down system.

The A90 panel meter can be supplied with factory fitted dual alarms each having a single pole changeover relay contact output. Each alarm may be independently conditioned as a high or low alarm.

When the A90 panel meter power supply is removed both alarm outputs will be de-energised. This condition should be chosen as the alarm condition when designing an alarm system.

For 4/20mA inputs see sections 5.4 and 5.4.1 which describe the Loop Break Detection **LFLB** function which will de-energise both alarm relays when the input current falls below 3.6mA.

When an alarm occurs an alarm annunciator on the A90 front panel is activated and if required the numerical display can alternate between the measured value and the alarm channel identification **RLr 1** or **RLr 2**.

CAUTION

The alarms are activated by the meter's numerical display. Use of the Tare Function **tArE will change the numerical display, the alarms will continue to function at the original displayed value, but this will correspond to a different input.**

Configurable functions for each alarm include adjustable setpoint, hysteresis, alarm delay and alarm accept.

7.3.1 Alarm relay contacts

Each alarm has a single pole change over relay output which as shown in Fig 10.

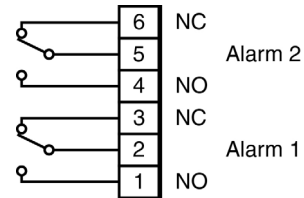

Fig 10 Alarm contact outputs

The contact rating are:

- ac 250V 5A
- dc 30V 5A

Inductive loads should be suppressed to ensure that the relay contact ratings are not exceeded.

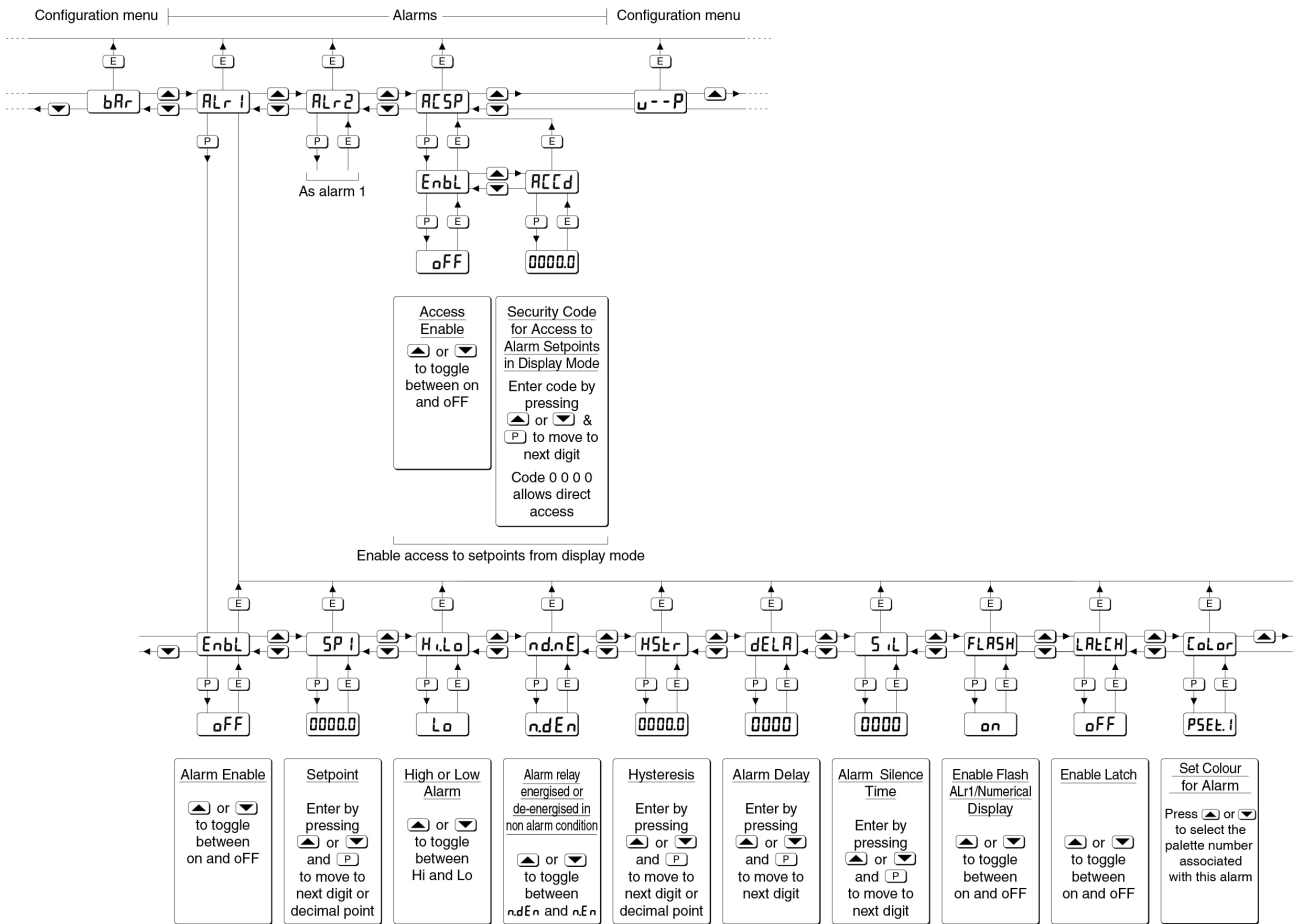

Fig 11 Alarm Configuration Functions

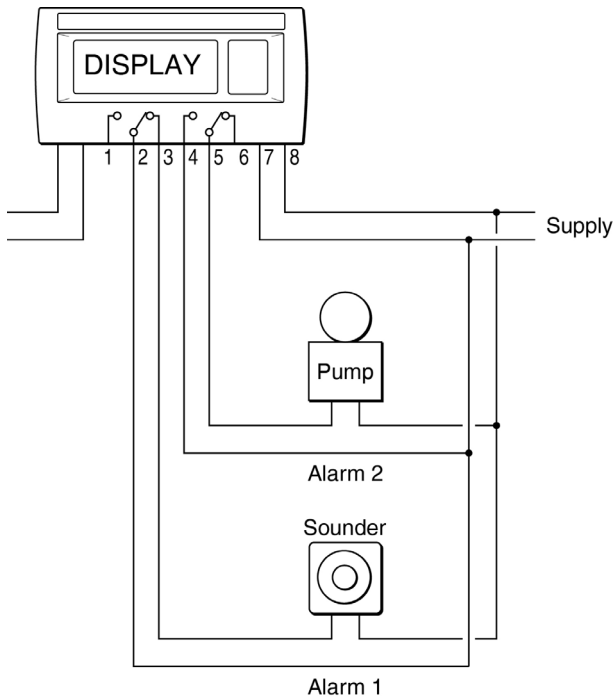



Fig 12 Typical alarm application
(Shown without recommended screen cables)

7.3.2 Configuration and adjustment

When optional alarms are fitted the A90 panel meter configuration menu is extended as shown in Fig 11. For simplicity Fig 11 only shows the additional functions for alarm 1, but alarm 2 has identical functions.

The following table summarises each of the alarm configuration functions and includes a cross reference to more detailed information. Again only the functions on alarm 1 are listed, but alarm 2 has identical facilities.

Display	Summary of function
EnbL	Alarm enable Enables or disables the alarm without changing the alarm parameters. See section 7.3.3
SP 1	Setpoint adjustment Adjusts the alarm setpoint. The alarm is activated when the meter display equals the setpoint. See section 7.3.4

Display	Summary of function
H.Lo	Alarm function Defines the alarm function as High or Low. See section 7.3.5
nd.nE	Alarm relay energised or de-energised in non alarm condition. Determines whether the alarm relay is energised or de-energised in the non alarm condition. See section 7.3.6
HStR	Hysteresis Adjusts the alarm hysteresis. See section 7.3.7
dELR	Alarm delay Introduces adjustable delay between the display equalling the setpoint and the alarm being activated. See section 7.3.8
S.L	Alarm silence time Defines the time that the alarm output remains in the non-alarm condition following acceptance of an alarm. See section 7.3.9
FLASH	Flash display when alarm occurs When enabled, alternates the A90 meter display between the process value and the alarm reference, R_{Lr1} or R_{Lr2} , when an alarm output is activated. See section 7.3.10
LATCH	Latch alarm output When enabled, maintains alarm output until the alarm is manually cleared by operating the  button. See section 7.3.11
Color	Display colour in Alarm condition Defines the colour of the A90 panel meter display when an alarm occurs. See section 7.3.12
RESP	Access to setpoint in display mode Sub-menu which enables direct access to the alarm setpoints from the A90 meter display mode, and defines a separate security code. See section 7.3.13

7.3.3 Alarm enable: E_{nbL}

This function allows each alarm to be enabled or disabled without altering any of the alarm parameters. To enable or disable the alarm select E_{nbL} from the alarm menu and press P which will reveal the current setting on or oFF . The function can be changed by pressing the \blacktriangledown or \blacktriangle button followed by the E button to return to the alarm menu.

7.3.4 Setpoint adjustment: $SP1$ and $SP2$

The setpoint of each alarm may be positioned anywhere in the numerical display of the A90 meter.

To adjust the setpoint select $SP1$ or $SP2$ from the alarm configuration menu and press P which will reveal the existing alarm setpoint with one digit flashing. The flashing digit and the position of the decimal point can be adjusted using the \blacktriangledown or \blacktriangle button, and the P button to move control to the next digit. When the required setpoint has been entered press E to return to the alarm configuration menu.

The alarm setpoints may also be adjusted when the A90 meter is in the display mode, see sections 7.3.13 and 7.3.14.

7.3.5 Alarm function: $H.Lo$

Each alarm can be independently configured as a high alarm or as a low alarm. To check or change the alarm function select $H.Lo$ from the alarm menu and press P to reveal the current setting. The function can be changed by pressing the \blacktriangledown or \blacktriangle button followed by the E button to return to the alarm menu.

7.3.6 Alarm relay energised or de-energised in non alarm condition: $nd.nE$

Configures the A90 meter alarm output relay to be energised nEn or de-energised $ndEn$ in the non alarm condition. For fail-safe alarm operation energised nEn should be chosen so the meter indicates an alarm condition when the A90 meter power supply fails or is disconnected.

- nEn Alarm output relay energised in non alarm condition.
- $ndEn$ Alarm output relay de-energised in non alarm condition.

To check or change the energised status of the A90 meter alarm relay, select $nd.nE$ from the alarm configuration menu and press P to reveal the existing setting. The function may be changed by pressing the \blacktriangledown or \blacktriangle followed by the E button to return to the alarm configuration menu.

7.3.7 Hysteresis: $H5tr$

Hysteresis is shown in the units that the meter has been calibrated to display.

To adjust the hysteresis select $H5tr$ from the alarm menu and press P which will reveal the existing hysteresis with one digit flashing. The flashing digit can be adjusted using the \blacktriangledown or \blacktriangle button, and the P button to move control to the next digit and the decimal point. When the required hysteresis has been entered press E to return to the alarm configuration menu.

e.g. An A90 meter calibrated to display temperature in $^{\circ}\text{C}$ with a high alarm set at 90.0°C and hysteresis of 0.5°C will perform as follows:

The high alarm will be activated when the increasing meter display equals 90.0 , but will not reset until the meter display falls below 89.5°C .

7.3.8 Alarm delay: $dELR$

This function delays activation of the alarm output for an adjustable time following the alarm condition occurring. The delay can be set in 1 second increments between 0 and 3600 seconds. If a delay is not required zero should be entered.

To adjust the delay select $dELR$ from the alarm configuration menu and press P which will reveal the existing delay time. The flashing digit of the delay can be adjusted using the \blacktriangledown or \blacktriangle button, and the P button to move control to the next digit. When the required delay has been entered press E to return to the alarm menu.

e.g. An A90 meter with a high alarm and an alarm delay of 30 seconds will perform as follows:

When the alarm condition occurs the A90 meter alarm annunciator will start to flash and, if enabled, the display colour will alternate between the display colour and alarm colour. If the alarm condition exists continuously for 30 seconds, the alarm output will be activated, the alarm annunciator will stop flashing and the meter display will be shown in the alarm colour.

If the $FLRSH$ function, which alternates the display between the alarm identification and the process variable display has been enabled, it will not start to function until the alarm is activated.

See section 7.3.10.

7.3.9 Alarm silence time: 5, L

This function is primarily intended for use in small installations where the alarm output directly operates an alarm annunciator such as a sounder or a beacon. When the alarm silence time, which is adjustable between 0 and 3600 seconds in 1 second increments, is set to any figure other than zero, the **[P]** button becomes an alarm accept button. After an alarm has occurred, operating the **[P]** button will cause the alarm output to revert to the non-alarm condition for the alarm silence time. If the alarm condition still exists at the end of the silence time, the alarm output will be reactivated. During the silence time the A90 meter alarm annunciator will flash and, if enabled, the display colour will alternate between the display colour and alarm colour until the silence time expires or the alarm is cleared.

If the *FLASH* function, which alternates the display between the alarm identification and the numerical display has been enabled, it will not start to function until the alarm is activated.

See section 7.3.10

To adjust the alarm silence time select 5, L from the alarm configuration menu and press **[P]** which will reveal the existing silence time with one digit flashing. The flashing digit can be adjusted using the **[▼]** or **[▲]** button and the **[P]** button to move control to the next digit. When the required silence time has been entered press **[E]** to return to the alarm menu.

7.3.10 Flash display when alarm occurs: FLASH

In addition to the two alarm annunciators on the meter display and, if enabled, the display colour change when an alarm occurs, this function identifies which alarm condition has occurred.

The *FLASH* function alternates the A90 meter display between the numerical value and the alarm reference, *RLr1* or *RLr2*, when the alarm output is activated. If both alarm outputs are activated, the alarm references are displayed in sequence.

To enable the function select *FLASH* from the alarm menu and press **[P]** which will reveal the current setting *on* or *off*. The function can be changed by pressing the **[▼]** or **[▲]** button followed by the **[E]** button to return to the alarm menu.

7.3.11 Latch alarm output: LRECH

For some applications it is desirable to retain the A90 meter alarm output after the alarm condition no longer exists. When enabled the *LRECH* function retains the alarm output, even if the alarm condition no longer exists, until it is manually cleared by operating the **[P]** button in the meter display mode.

To enable the function select *LRECH* from the alarm menu and press **[P]** which will reveal the current setting *on* or *off*. The function can be changed by pressing the **[▼]** or **[▲]** button followed by the **[E]** button to return to the alarm menu.

When *LRECH* is enabled the A90 meter will respond to an alarm condition in the normal way. However, when the alarm condition no longer exists the A90 meter will remain in the alarm condition until manually cleared by operating the **[P]** button in the A90 meter display mode.

7.3.12 Display colour in alarm condition: Colour

When an alarm output is activated the colour of the A90 meter display can be changed to make the alarm as conspicuous as possible. Any one of the preset colours defined in the *Colour* function in the main meter configuration menu may be selected, see section 5.14.

To check or change the alarm colour select *Colour* in the alarm menu and press **[P]** which will reveal the current alarm colour. The alarm colour can be changed by pressing the **[▼]** or **[▲]** button to scroll through the seven preselected colours. When the required colour has been selected press the **[E]** button to enter the selection and return to the alarm menu.

When both alarm 1 and alarm 2 are activated at the same time, the colour selected for alarm 2 will be displayed.

7.3.13 Access to setpoint in display mode: RESP

This function enables a separate menu that provides direct access to the alarm setpoints from the display mode by simultaneously operating the **[P]** and **[▲]** push buttons. An operator can therefore adjust the alarm setpoints without having access to the A90 meter's configuration menu. Protection against accidental adjustment of the setpoints can be provided by a separate security code.

This direct setpoint access menu is enabled and a separate access code entered from the *RESP* function in the main meter configuration menu as shown in Fig 11. To check or change this function select *RESP* from the main meter configuration menu and press **[P]** which will display the function

enable prompt **EnbL**. Pressing **P** again will reveal if the direct access menu is **on** or **off**. The **▼** or **▲** button will then toggle the display between the two conditions.

If **off** is selected, the operator will not have access to the setpoints from the display mode. If **on** is selected, the operator will have access. When set as required pressing **E** will enter the selection and return the display to the **EnbL** prompt.

Access to the setpoints from the meter display mode may be protected by a four digit code. Default code **0000** allows direct access to the setpoints from the A90 meter display mode by pressing the **P** and **▲** buttons simultaneously.

To define this access code press **P** to return to the **EnbL** prompt followed by the **▼** or **▲** button to select the access code prompt **REEd**. Pressing **P** will then reveal the current security code with one digit flashing. The flashing digit may be changed by operating the **▼** or **▲** button and control transferred to the next digit by pressing the **P** button. When the required code has been entered, pressing **E** twice will store the code and return the display to the **RESP** prompt in the meter configuration menu.

7.3.14 Adjusting alarm setpoints from the display mode.

Access to the alarm setpoints from the A90 meter display mode is obtained by operating the **P** and **▲** buttons simultaneously as shown in Fig 13. If the setpoints are not protected by a security code the alarm setpoint prompt **SP 1** will be displayed. If the setpoints are protected by a security code, **Code** will be displayed first, pressing **P** again will result in **0000** being displayed with the first digit flashing. The access code can then be entered using the **▼** or **▲** button to adjust the flashing digit and the **P** button to move control to the next digit. If the correct code is entered, pressing **E** will result in the **SP 1** prompt being displayed.

If an incorrect security code is entered, or a button is not pressed within twenty seconds, the A90 meter will automatically return to the display mode.

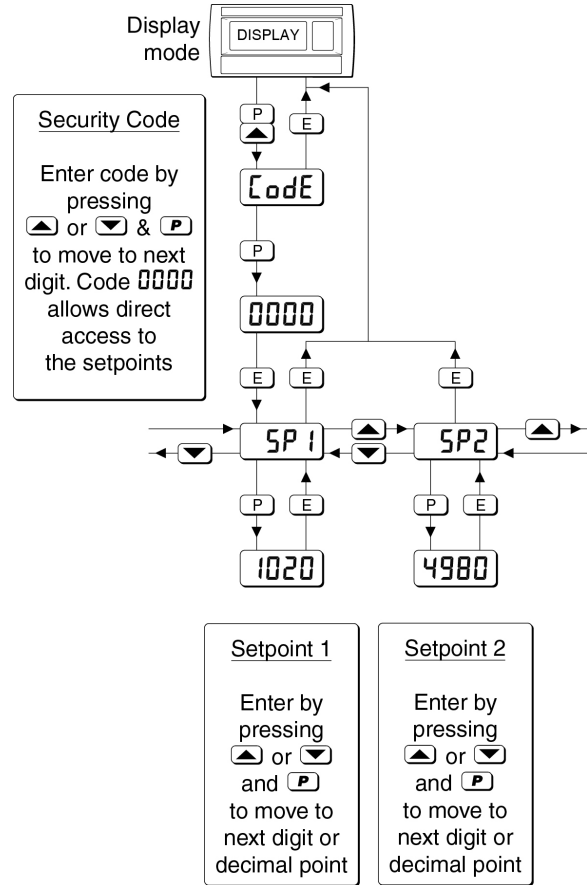

Fig 13 Setpoint adjustment from the display mode

To adjust an alarm setpoint select **SP 1** or **SP 2** and press **P** which will reveal the current setting with one digit flashing. Each digit of the setpoint may be adjusted using the **▼** or **▲** button and the **P** button to move control to the next digit and the decimal point. When the required setpoint has been entered, pressing **E** will return the display to the **SP 1** or **SP 2** prompt from which the other setpoint may be selected, or the A90 meter may be returned to the display mode by pressing **E** again.

Note: With the A90 meter in the display mode, direct access to the alarm setpoints is only available when the **RESP** menu is enabled - see section 7.3.13

7.3.15 Displaying setpoints on the bargraph

One of the selectable bargraph formats *RLr5P* allows a low or a high setpoint plus the displayed value to be represented, or a low and a high setpoint plus the displayed value to be represented by the bargraph as shown in Fig 14.

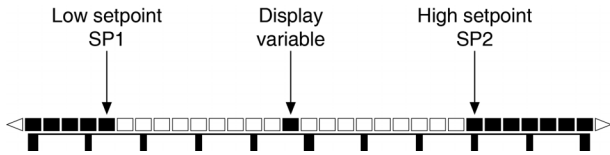

Fig 14 Displayed value and setpoints on bargraph

The bargraph area below the low alarm setpoint and the area above the high alarm setpoint are activated. The displayed variable is represented by an activated segment which moves between these low and high alarm setpoints.

When the activated segment representing the displayed variable is adjacent to the area representing the low or high alarm setpoints, the segment flashes. When a displayed variable equals the low or high alarm the complete bargraph representing the activated alarm flashes irrespective of whether the alarm output has been delayed or cleared.

For this function to operate *SP1* must be conditioned as a low alarm and *SP2* as a high alarm; *SP1* must always be less than *SP2*. Incorrect configuration is shown by a flashing bargraph scale with no activated bars.

7.4 4/20mA output and transmitter supply

The A90 panel meter can be supplied with a factory fitted isolated 4/20mA current sink and a galvanically isolated 24V dc supply as shown in Fig 1. Connecting the 24V supply in series with the current sink produces a 4/20mA current source output. The 24V dc output may also be used to power a remote transmitter.

7.4.1 4/20mA output loop design

The 4/20mA output is a current sink i.e. not powered, but it is totally isolated from all other A90 meter circuits. It is effectively a 2-wire 4/20mA transmitter requiring a minimum supply of 5V with its current controlled by any required part of the A90 meter display. Terminals 18 and 19 may be connected to any other instrument which will accept a 4/20mA transmitter input as shown in Fig 15.

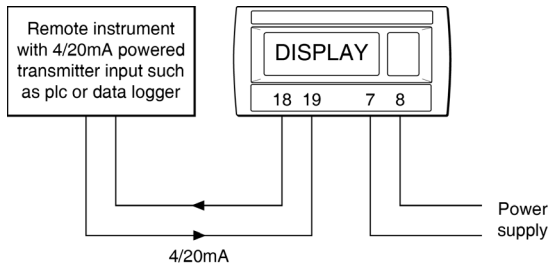

Fig 15 Current sink output

Connecting the 4/20mA current sink in series with the 24V dc power supply produces a 4/20mA current source output capable of driving up to a 19V load such as a loop powered remote indicator. Terminals 19 and 21 are isolated and may be connected to any other instrument which will accept a 4/20mA input as shown in Fig 16.

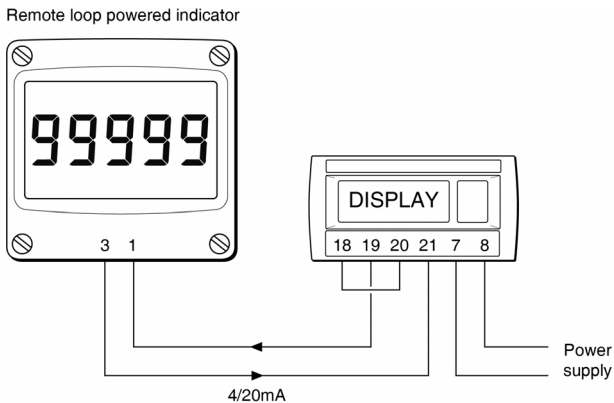

Fig 16 Current source output

7.4.2 System design for powering a transmitter

The 24V dc power supply is galvanically isolated and may be used to power a 2-wire 4/20mA remote transmitter and to display its output in engineering units as shown in Fig 17

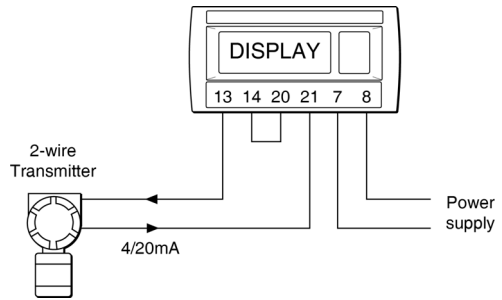

Fig 17 Powering and displaying output from a remote loop powered 2-wire transmitter.

7.4.3 Configuration and calibration

When an A90 meter is supplied with an optional 4/20mA output the configuration menu is extended as shown in Fig 18

The 4/20mA output current is controlled by the A90 meter display. Meter displays corresponding to 4mA and 20mA outputs are defined in the sub-menu.

The A90 meters 4/20mA output range is 3.8mA to 20.5mA, unless the *FRuLt* function in the sub-menu is activated.

When the 4/20mA output is disabled, the output current is a constant 3.5mA irrespective of the meter display.

When the A90 meter is configured to display a 4/20mA input, activation of the input break detection *LFLo* will result in a constant 3.5mA output. See sections 5.4 and 5.4.2

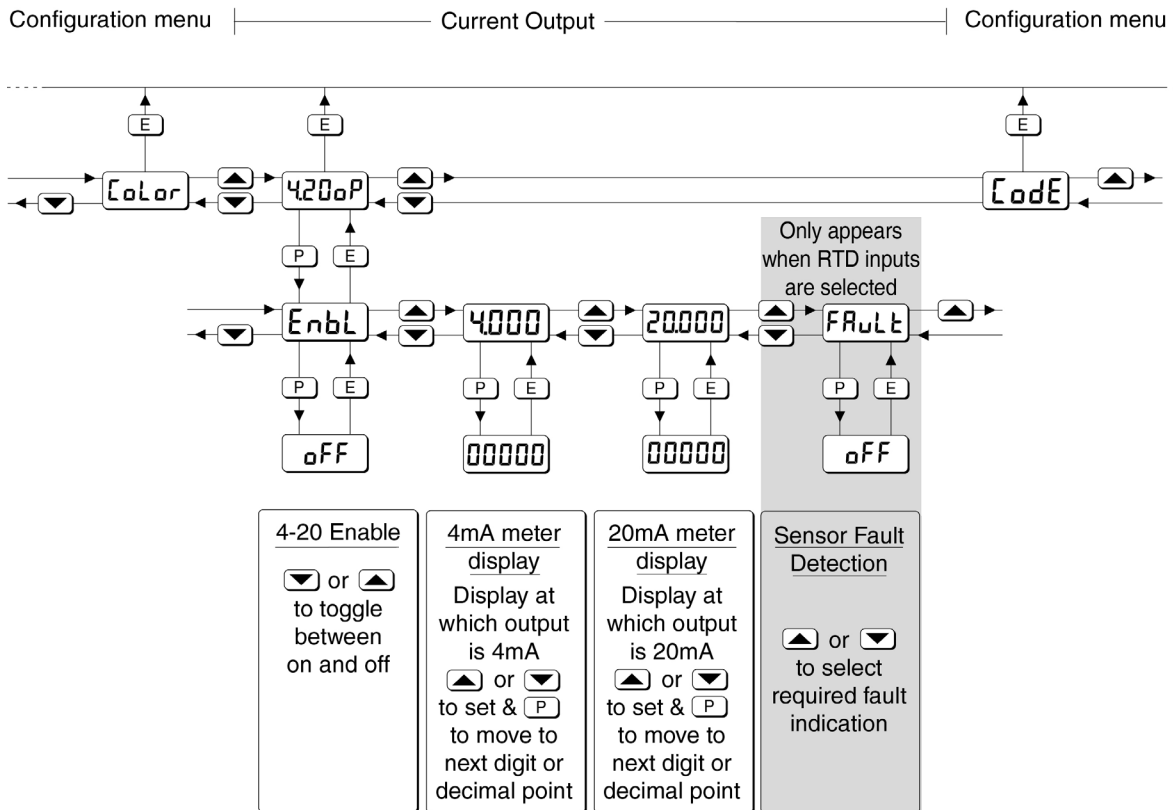

Fig 18 4/20mA output configuration sub-menu

7.4.4 4/20mA enable: EnbL

This function allows the 4/20mA output to be enabled or disabled without altering its calibration. To enable or disable the 4/20mA output select EnbL from the 4-20mA sub-menu and press P which will reveal the current setting on or off. The function can be changed by pressing the ▼ or ▲ button followed by the E button to return to the 4-20mA sub-menu. When disabled the output current is a constant 3.5mA irrespective of the meter display.

7.4.5 Display which corresponds to 4mA output: 4.000

The A90 meter display which corresponds to a 4.000mA output current is defined by this function. Using the ▼ or ▲ push button select 4.000 in the 4/20mA output sub-menu and press P to reveal the existing display with one digit flashing. The required display can be entered using the ▼ or ▲ push button to adjust the flashing digit and the P button to transfer control to the next digit. When set as required, press E to enter the value and return to the 4.000 prompt in the 4/20mA output sub-menu.

7.4.6 Display which corresponds to 20mA output: 20.000





The A90 meter display which corresponds to a 20.000mA output current is defined by this function. Using the ▼ or ▲ push button select 20.000 in the 4/20mA output sub-menu and press P to reveal the existing display with one digit flashing. The required display can be entered using the ▼ or ▲ push button to adjust the flashing digit and the P button to transfer control to the next digit. When set as required, press E to enter the value and return to the 20.000 prompt in the 4/20mA output sub-menu.

Note: If the A90 meter calibration is changed the 4/20mA output will be disabled and the output current will be set to 3.5mA irrespective of the meter display. The 4/20mA output should therefore always be reconfigured following changes to the A90 meter configuration.

7.4.7 RTD fault detection: **FRuLE**

Fault function is only included in the 4/20mA configuration menu when the A90 meter is configured for a Resistance Thermometer input.

If the Resistance Thermometer is significantly below or above its anticipated resistance value, the function sets the 4/20mA output current to one of three out of range values which are selected in this sub-function.

Using the  or  button select **FRuLE** in the 4/20mA output sub-menu and press  to reveal the existing setting. One of three output currents may be selected by operating the  or  button, or the function may be disabled by selecting **oFF**.

Output currents

Select	Output current
oFF	
dn 3.6	3.6mA
dn 3.8	3.8mA
uP 21	21mA

Resistance Thermometer fault is considered to exist when resistance is below or above following limits:

	Lower	Upper
3-wire RTD	5Ω	500Ω
2-wire RTD	10Ω	550Ω
Differential RTDs	10Ω	550Ω

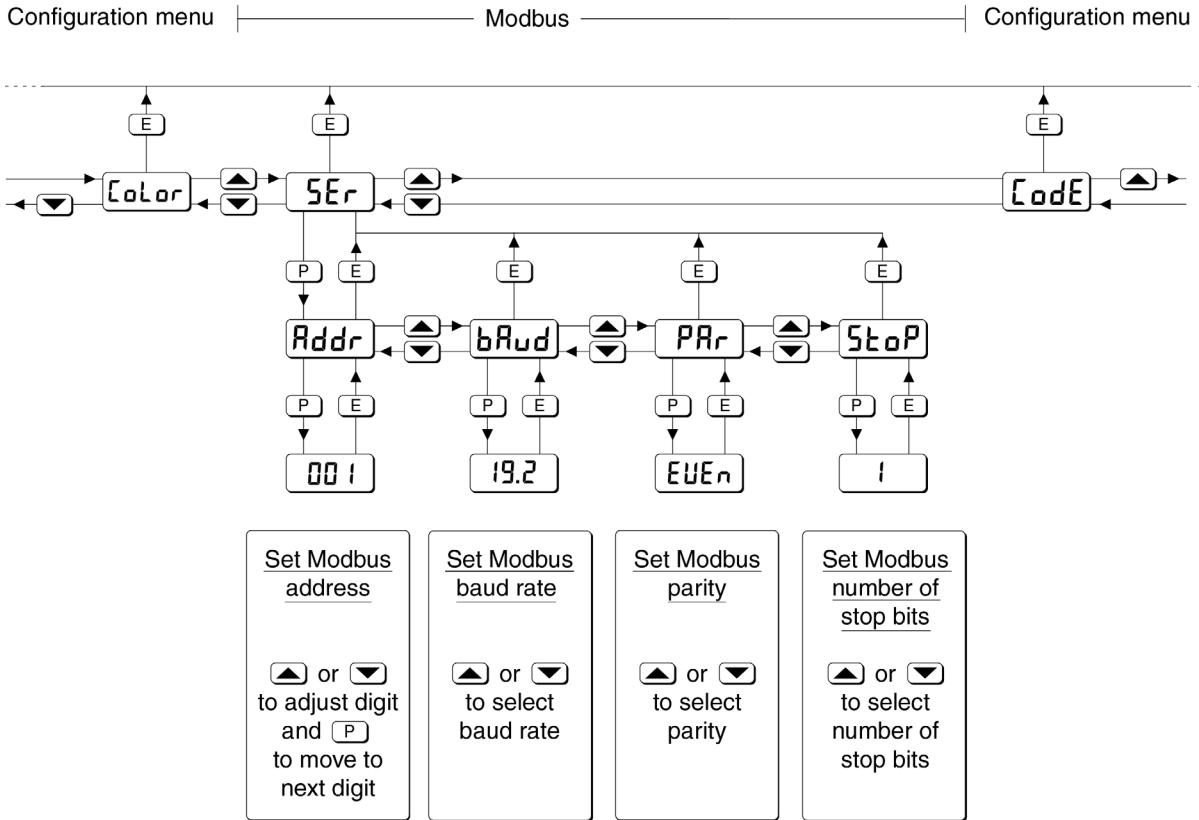

Fig 19 Modbus configuration sub-menu

7.5 Modbus RTU

The A90 panel meter can be supplied with a factory fitted isolated Modbus RTU interface (Modbus over RS485). This enables a Modbus master to monitor the process variable measured by the A90 process panel meter and to monitor the status of the A90 meter. The A90 process panel meter can also be configured via the Modbus interface.

The Advisor A90 Modbus interface guide, which can be downloaded from the BEKA website www.beka.co.uk, provides a detailed descriptions of the functions included and how they may be used.

Connection to the Modbus interface is via a three way rear of panel plug-in terminal block. The terminal block location and connection details are shown in Fig 6.

7.5.1 Configuration

When an A90 meter is supplied with an optional Modbus interface the configuration menu is extended as shown in Fig 19

7.5.2 Modbus address: Addr

This function allows the A90 meter's Modbus address to be entered.

Select the Modbus sub-menu 5Er in the instrument configuration menu and press **P** to enter. This will show the first Modbus function Addr. Pressing **P** again which will show the current Modbus address with one digit flashing. The flashing digit may be changed by pressing the **▼** or **▲** button followed by the **P** button to move to the next digit. The meter's Modbus address can be set from 001 to 247. When the required address has been entered, the **E** button will return the display to the Addr prompt from which another Modbus parameter may be selected.

7.5.3 Modbus baud rate: bAud

One of five Modbus communication speeds is selected by this function. Select the bAud function in the Modbus sub-menu and press **P** to reveal the current setting. Using the **▼** or **▲** button scroll through the following five speeds which are shown in kbaud.

- 9.6
- 19.2
- 38.4
- 57.6
- 115.2

When the required speed is displayed, pressing **E** will enter the selection and return the display to the bAud prompt.

7.5.4 Odd, even or no parity: PAr

Odd, even or no parity may be selected with this function. To check or change the configuration select the PAr function in the Modbus sub-menu and press **[P]** to reveal the current setting. Using the **[▼]** or **[▲]** button scroll through the three options, *odd*, *even* and *none*. When set as required, pressing **[E]** will enter the selection and return the display to the PAr prompt.

7.5.5 Number of stop bits: StOP

1 or 2 stop bits may be selected with this function. Select the StOP function in the Modbus sub-menu and press **[P]** to reveal the current setting. Using the **[▼]** or **[▲]** button toggle the display between 1 and 2. When set as required, pressing **[E]** will enter the selection and return the display to the StOP prompt.