



CYCLOPS

Z – Purge Indicator



- Low unit & installation cost
- Simple to install & use
- No tubing or conduit
- Reliable & maintenance free
- Built in primary exhaust vent
- Local indicator & remote status alarm standard
- Anodized aluminum or 316 stainless steel
- 12 or 24 VDC & 115 or 230 VAC
- Continuous Dilution or Leakage Compensation Protective Gas Inlet Kits

OVERVIEW:

To prevent the possibility of fire or explosion inside the enclosures of energized electrical equipment, a protective gas supply is used to purge and dilute potentially flammable vapors to an acceptable level, creating a safe area for the devices within the enclosure. Positive pressure prevents the ingress of flammable vapors or combustible dust in the surrounding atmosphere from entering into the enclosure as long as minimum overpressure is maintained. After the enclosure is purged and minimum overpressure is being maintained, power may be manually connected to the protected electrical equipment.

The Purge Solutions, Inc. CYCLOPS Z – Purge Indicator provides objective evidence of enclosure minimum overpressure with both a visible indicator and a dry-contact output for remote status monitoring. The enclosure primary exhaust vent is an integrated part of the Z – Purge Indicator's casing, which mounts directly to enclosure being monitored. No tubing, ridged conduit, cable glands or cable is required to install.

FEATURES:

- CYCLOPS Z – Purge Indicator mounts directly to enclosure. (Refer to Figures 1, 2, 3, & 4)
- Primary exhaust vent is an integrated part of the Z – Purge Indicator casing. (Refer to Figure 4)
- Dry contact output for remote monitoring is supplied as standard. Contact open on alarm (Standard). Contact closed on alarm (Optional). Order optional contact closed on alarm by adding an “X” at end of Purge Solutions, Inc. model number. (Refer to Figure 4)
- Rugged, visual green LED indicator. Green LED is illuminated when minimum overpressure is being maintained inside enclosure being monitored. Green LED is not illuminated when minimum overpressure not being maintained inside enclosure being monitored.
- The CYCLOPS Z – Purge Indicator is certified to ATEX, CEC, IECEx, NEC, NFPA, UKEx and CE Marked for installation and use in Division 2, Zone 2 and Zone 22 hazardous areas.

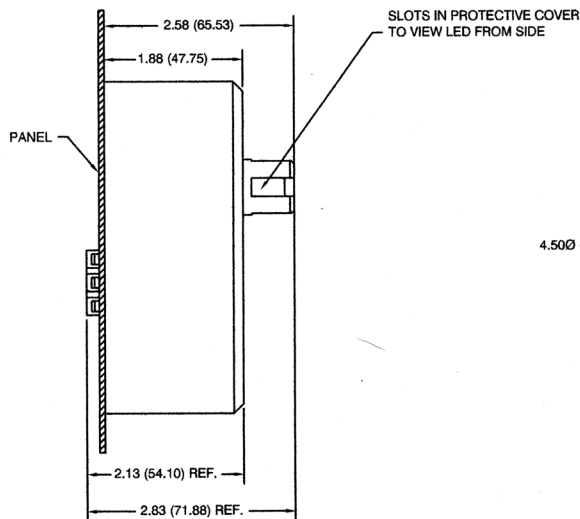

SIDE VIEW

Figure 1

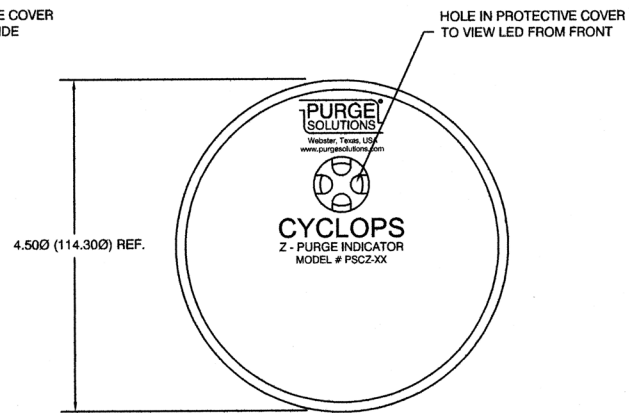

FRONT VIEW

Figure 2

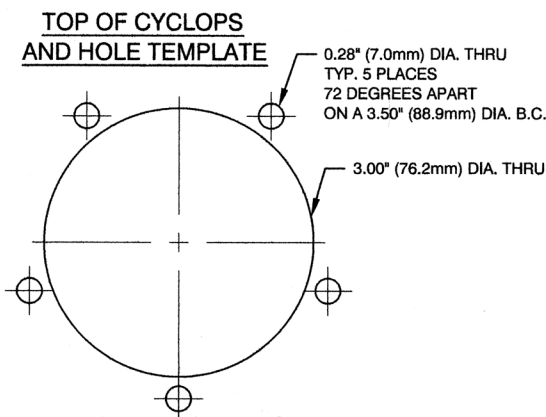

Figure 3

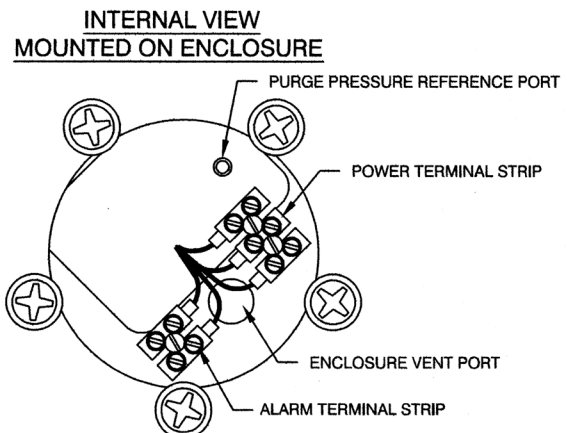
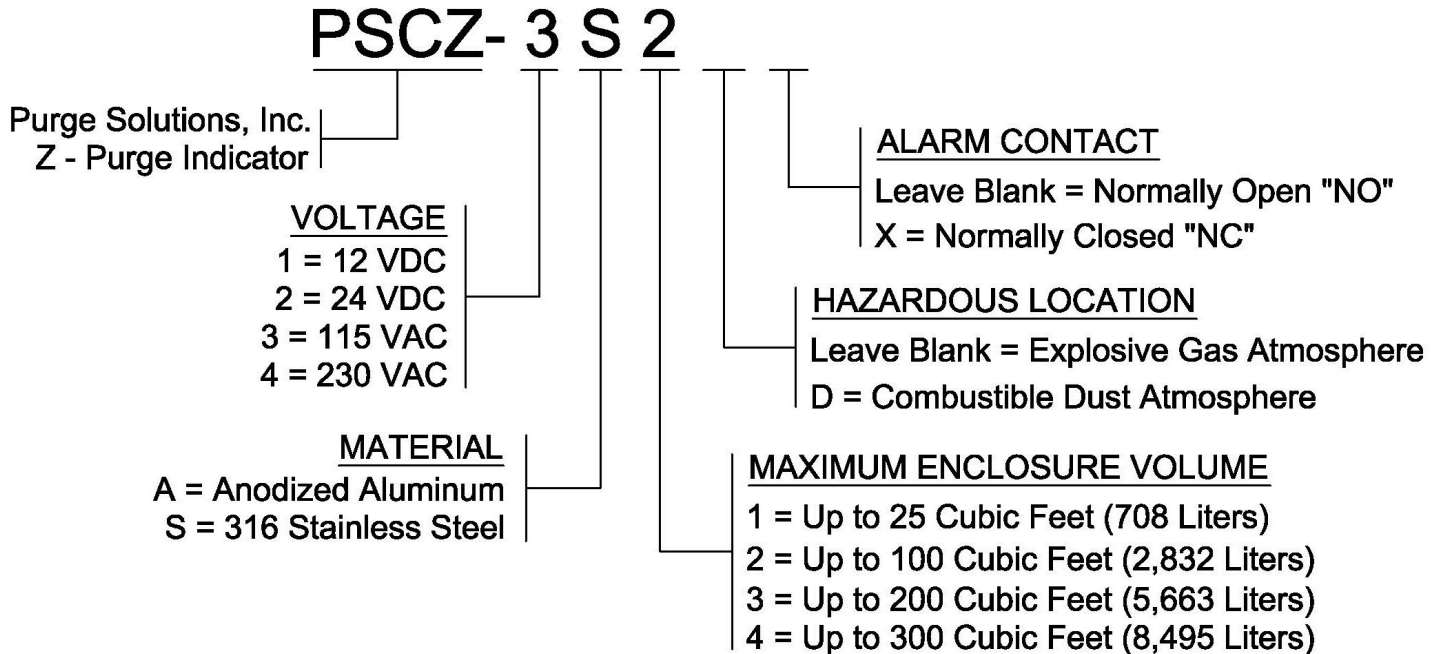

Figure 4

CYCLOPS Z-PURGE INDICATOR MODEL NUMBER MATRIX:



NOTE: Voltage, Material, Maximum Enclosure Volume, Hazardous Location and Alarm Contact; selections are made by end user to meet final purge and pressurization application requirements (MODEL NUMBER SHOWN ABOVE IS AN EXAMPLE).

NOTE: Selection of Protective Gas Inlet Kit and flow rate should be based on available protective gas volume at installation site; not on maximum volume of protective gas that selected Protective Gas Inlet Kit can supply.

Z – PURGE AND PRESSURIZATION SYSTEM PROTECTIVE GAS INLET KITS:

The CYCLOPS Z – Purge Indicator uses two different methods to purge the enclosure(s) and maintain a minimum overpressure of at least 0.30 inch H₂O (0.75 mbar) for explosive gas atmospheres or 0.5 inch H₂O (1.25 mbar) for combustible dust atmospheres; continuous dilution or leakage compensation.

- **Continuous Dilution Protective Gas Inlet Kits:** Continuous dilution is a method of maintaining the same pressure / flow rate during and after the enclosure has been purged below the required lower explosive limit (LEL). The protective gas is passed continuously through the enclosure at a minimum overpressure above that of the required 0.30 inch H₂O (0.75 mbar) for gas hazardous locations or 0.5 inch H₂O (1.25 mbar) for dust hazardous locations and discharged continuously to the outside atmosphere through an exhaust vent. The same volume of protective gas is maintained during and after the purge cycle time. Continuous dilution is normally used to help heat buildup from the electronics within the pressurized panel by continuously exchanging protective gas through the electronics panel to atmosphere. The maximum flow rate that the Continuous Dilution Purge Gas Inlet Kit can supply is 80 SCFM (2,265 LM). Continuous Dilution Protective Gas Inlet Kits are available in materials of anodized aluminum or 316 stainless steel.

- **Manual Leakage Compensation Purge Gas Inlet Kits:** The second purge method offered by Purge Solutions, Inc. is leakage compensation, which allows a higher volume of protective gas supply to be manually selected to speed up the purge cycle time, permitting a more-rapid application of initial power or restoration of power to protected electrical equipment, after service. When the purge cycle has elapsed, the larger volume of purge gas can be manually turned off. A volume of purge gas larger than the leak rate of the enclosure will be introduced into the now protected enclosure to maintain a minimum overpressure of at least 0.30 inch H₂O (0.75 mbar) for gas hazardous locations or 0.5 inch H₂O (1.25 mbar) for dust hazardous locations. Leakage compensation is normally used to conserve protective gas when utilities are at a premium. The maximum flow rate that the Leakage Compensation Purge Gas Inlet Kit can supply is 80 CFM (2,265 LM). Both Leakage Compensation Protective Gas Inlet Kits are available in materials of anodized aluminum or 316 stainless steel.

OPTIONS & ACCESSORIES AVAILABLE:

- **Vortex Cabinet Cooler Systems:** For applications where thermal management of electrical cabinets and control panels are required; Purge Solutions, Inc. offers Vortex Cabinet Cooler Systems, which provide cooling capacities for your application, maintain a NEMA 4X (IP66) rating and are constructed for installation and use in hazardous locations. These Vortex Cabinet Cooler Systems can be used in combination with our Z – Purge Indicators. If a Continuous Vortex Cooler is used it can supply protective gas to the panel; taking the place of a Protective Gas Inlet Kit. The Thermostat Controlled Vortex Cooler uses a mechanical thermostat, which eliminates the need for a solenoid valve and electrical power to the thermostat and solenoid valve. Contact your local Purge Solutions, Inc. representative or the factory for sizing of system and installation information.

NOTE: There are special modifications and sizing requirements to be made before Vortex Cabinet Coolers are able to be installed and used in a hazardous location.

- **Increased Safety Enclosures:** Purge Solutions, Inc. also offers ATEX, IECEx and NEMA rated increased safety enclosures in several standard enclosure sizes or we can custom built to the customer specifications, including all holes and cutouts for cable glands, widows, purge systems and any other component can be incorporated into fabrication. As long as the design stays within our conditions of certification no additional assessment and testing is required to maintain ATEX, IECEx, NEMA and UKEx certification. Our proprietary hinge design allows clamping of door on all four sides for maximum ingress protection with incorporated fasteners that allows door to be removed as needed. Enclosures can be fabricated from 304 or 316 stainless steel, powder coated carbon steel or aluminum with all seams continuously welded and ground before finish is applied. Contact your local Purge Solutions, Inc. representative or the factory for sizing of system and installation information.
- **Increased Safety Window Kits:** For purged / pressurized or increased safety enclosures that require viewing of components mounted within the enclosure; Purge Solutions, Inc. offers both opening and non-opening Increased Safety Window Kits in several standard window viewing sizes, which can be mounted on the door, sides, top or bottom of an enclosure. If there is not a viewing opening listed in our standard sizes that meets your application requirements; we can custom build an opening or non-opening Increased Safety Window Kit for you. As long as the design stays within our conditions of certification no additional assessment and testing is required to maintain ATEX, IECEx, NEMA and UKEx rated certification. Contact Purge Solutions, Inc. to discuss application needs.

GENERAL SPECIFICATIONS:

- **Unit Weight:**
 - CYCLOPS Z – Purge Indicator, Anodized Aluminum = 2.5 lbs. (1.2 kg)
 - CYCLOPS Z – Purge Indicator, 316 Stainless Steel = 6.7 lbs. (3.1 kg)
 - Continuous Dilution Protective Gas Inlet Kit, Small, Anodized Aluminum = 2.0 lbs. (0.9 kg)
 - Continuous Dilution Protective Gas Inlet Kit, Small, 316 Stainless Steel = 2.8 lbs. (1.3 kg)
 - Continuous Dilution Protective Gas Inlet Kit, Med. & Large, Anodized Aluminum = 3.0 lbs. (1.4 kg)
 - Continuous Dilution Protective Gas Inlet Kit, Med & Large, 316 Stainless Steel = 4.2 lbs. (1.9 kg)
 - Leakage Compensation Protective Gas Inlet Kit, Small, Anodized Aluminum = 4.0 lbs. (1.8 kg)
 - Leakage Compensation Protective Gas Inlet Kit, Small, 316 Stainless Steel = 5.5 lbs. (2.5 kg)
 - Leakage Compensation Protective Gas Inlet Kit, Med & Large, Anodized Alum. = 4.8 lbs. (2.2 kg)
 - Leakage Compensation Protective Gas Inlet Kit, Med. & Large, 316 Stainless = 6.9 lbs. (3.1 kg)
 - Back-Up Vent, Small, Side or Top Mount, Anodized Aluminum = 1.3 lbs. (0.6 kg)
 - Back-Up Vent, Small, Side or Top Mount, 316 Stainless Steel = 2.4 lbs. (1.1 kg)
 - Back-Up Vent, Medium, Side or Top Mount, Anodized Aluminum = 2.3 lbs. (1.0 kg)
 - Back-Up Vent, Medium, Side or Top Mount, 316 Stainless Steel = 4.0 lbs. (1.8 kg)
 - Back-Up Vent, Large, Side or Top Mount, Anodized Aluminum = 4.9 lbs. (2.2 kg)
 - Back-Up Vent, Large, Side or Top Mount, 316 Stainless Steel = 11.8 lbs. (5.4 kg)
- **Operating Temperature Range:**
 - 40°F to 150°F (- 40°C to 65°C)
- **Minimum Overpressure Switch Settings:**
 - 0.30 inch H₂O (0.75 mbar) for gas hazardous locations
 - 0.50 inch H₂O (1.25 mbar) for dust hazardous locations
- **Ingress Protection:**
 - Anodized aluminum and 316 Stainless Steel = NEMA 4X (IP66)
- **Power Input / Consumption:**
 - 0.5 Watts maximum
- **Voltage:**
 - 12 VDC Model, polarity-protected
 - 24 VDC Model, polarity-protected
 - 115 VAC Model, 50 / 60 Hz
 - 230 VAC Model, 50 / 60 Hz
- **Alarm Dry Contact Maximum Continuous Load Rating:**
 - Contact open on alarm (NO)
 - Contact closed on alarm (NC)
 - 150 mA rms AC
 - 150 mA DC
- **Standard Hardware:**
 - All mounting fasteners, O-ring, warning label, and USB with unit documentation



GENERAL SPECIFICATIONS CONTINUED:

- **Hazardous Area Approvals:**

ATEX, IECEx and UKEx

II 3G Ex ec ic [pzc] IIC T6 Gc for Zone 2 gas hazardous areas

II 3D Ex ic [pzc] tc IIIC T79°C Dc IP66 for Zone 22 dust hazardous areas

ANSI / ISA 12.4, CEC, NEC and NFPA 496

Class I, Division 2, Group A, B, C & D, T6 “for gas hazardous areas”

Class II, Division 2, Group F & G, T6 “for dust hazardous areas”

Certified to an Ambient Temperature Range of - 40°F (- 40°C) ≤Tamb≤ + 149°F (+ 65°C)

CE Marked