

D1xC1X05R 110dB(A) Radial Alarm & 5J Xenon Strobe

The D1xC1X05R is a globally certified alarm horn sounder with a compact, omni-directional horn and combined with a 5 Joule Xenon strobe beacon. The robust Type 4/4X, IP66 marine grade, corrosion proof aluminium enclosure is approved for Class I & II Div 1, Zone 1 & 20, IECEx and ATEX 1, 2, 21 & 22 explosion proof signalling applications.

Featuring 64 alarm tone sounds, each of the available 4 stage/channels can be remotely triggered. Class D amplification provides a high sound output at optimum operating current. The threaded flameproof joint, multiple cable entries and duplicated, pluggable termination simplifies both installation and routine maintenance. The 24Vdc Class I version is approved for public (alarm horn) and private mode fire alarm use (strobe beacon).

Features

- Maximum sound pressure level output of 110dB(A)
- Automatic synchronisation on multi-beacon & sounder systems
- UL464 / CAN/ULC-S525 & UL1638 / CAN/ULC-S526

Approvals

- UL/cUL/ULC File ref: E230764
- IECEx Certificate: IECEx ULD 19.0008X
- ATEX Certificate: DEMKO 19 ATEX 2141X
- CSFM listing: 7136-2279:0506
- UKCA certificate: UL21UKEX2132X

Coding

- NEC Class / Zone
 - Class I Zone 1 IIC T4 Gb Ta -55°C to +85°C
 - Class I Zone 1 IIC T4A Gb Ta -55°C to +80°C
 - Class I Zone 1 IIC T5 Gb Ta -55°C to +60°C
 - Class I Zone 1 IIC T6 Gb Ta -55°C to +45°C
 - CEC Class / Zone
 - Class I Zone 1 IIC T5 Gb Ta -55°C to +55°C
 - Class I Zone 1 IIC T6 Gb Ta -55°C to +45°C
 - NEC Class / Div
 - Class I Div 1 ABCD T4 Ta -55°C to +85°C
 - Class I Div 1 ABCD T4A Ta -55°C to +80°C
 - Class I Div 1 ABCD T5 Ta -55°C to +60°C
 - Class I Div 1 ABCD T6 Ta -55°C to +45°C
 - CEC Class / Div
 - Class I Div 1 ABCD T5 Ta -55°C to +55°C
 - Class I Div 1 ABCD T6 Ta -55°C to +45°C
 - IECEx / ATEX
 - II 2G Ex db IIC T4/T5 Gb Ta -55°C to +75°C
 - II 2G Ex db IIC T5 Gb Ta -55°C to +55°C
 - II 2G Ex db IIC T6 Gb Ta -55°C to +40°C (DC only)
 - II 2D Ex tb IIIC T115°C Db Ta -55°C to +75°C
 - NEC Class / Zone - Product version: D
 - Class II Zone 20 IIIB T4A Gb Ta -55°C to +70°C
 - NEC Class / Div - Product version: D
 - Class II Div 1 Group FG T4A Ta -55°C to +70°C
- See product manual for full voltage specific coding.



Specification

Alarm Horn:

Maximum output:	110dB(A) @ 1 metre [101dB(A) @ 10ft/3m] Class II version: 94dB(A) @ 1 metre [85dB(A) @ 10ft/3m]
Nominal output:	105dB(A) @ 1m +/- 3dB - Tone 4 [96dB(A) @ 10ft/3m] Class II version: 90dB(A) @ 1 metre [81dB(A) @ 10ft/3m]
No. of tones:	64 (UK00A / PFEER compliant)
No. of stages:	4
Volume control:	Full range
Effective range:	125m/410ft @ 1KHz
Voltages DC:	24Vdc (20-28Vdc)
Voltages AC:	110-120Vac, 220-240Vac
Stage switching:	DC units: negative or positive AC units: common supply line

Strobe Beacon:

Energy:	5 Joules (5Ws)
Flash rates:	Option 1: 1Hz (60 fpm) Option 2: 1.5Hz (90 fpm) Option 3: Double Strike
Eff. Intensity:	143 cd* - measured ref. to I.E.S.
Peak Candela:	46,976 cd* - measured ref. to I.E.S.
Eff. Intensity:	250 cd - calculated from energy (J)
Peak Candela:	500,000 cd - calculated from energy (J)
Lens colours:	Amber, Blue, Clear, Green, Magenta, Red & Yellow
Tube life :	Emissions reduced to 70% > 5 million flashes

General:

Ingress protection:	EN60529: IP66 UL50E / NEMA250: 4 / 4X / 3R / 13
Enclosure material:	Marine grade aluminium LM6 - copper free Chromated & powder coated - corrosion proof
Enclosure colour:	Red or Grey, custom colours available on request
Cable entries:	1x1/2"NPT & 2xM20 - thread adaptors available
Terminals:	0.5 - 2.5mm ² (20-14 AWG) Pluggable, duplicated terminals
Grounding stud:	M5
Line monitoring:	Blocking diode included. EOL Min. 500 Ohm 2W, or 3k3 Ohm 0.5W resistor or diode (DC versions) can be fitted
Enclosure volume:	<2 litres
Installation temp:	-55 to +85°C [-67° to +185°F]
Storage temp:	-55 to +85°C [-67° to +185°F]
Relative humidity:	99%
Vibration test:	35Hz for a duration 4Hr (UL464)
Jarring test:	3ft/lb Energy (UL464)
Impact test:	3x 5lb (UL464)
Relative humidity:	95% - Additional tropicalisation is recommended for applications where both high relative humidity and high ambient temperatures exist
Weight:	4.9kg/10.9lbs

Part Codes

Part Code:	Identifier:	Description:
Product type:	D1xC1X05	Combined Alarm Horn & Xenon Strobe
Horn type:	R	Omni-directional radial horn
Voltage:	DC024 AC115 AC230	20-28V dc 110-120Vac 220-240Vac
Cable entries:[e]	A B C D F G Note:	2 x M20x1.5mm & 1 x 1/2"NPT 2 x 1/2"NPT - adaptors 2 x 3/4"NPT - adaptors 2 x M25x1.5mm - adaptors 1 x 3/4"NPT - adaptor 1 x M25x1.5mm - adaptor All entries, excluding thread adaptors, supplied with stopping plugs installed.
Stopping plug/ adaptor material: [m]	B N S	Brass Nickel Plated Stainless Steel
Bracket/Guard material: [s]	1 3 6 7	A4 316 Stainless Steel A4 316 St/St with Equip. Tag Surface bracket A4 316 SS Surface bracket A4 316 SS with Equip. Tag
Product version: [v]	A D	UL, cUL, ULC, IECEx, ATEX, PESO, CSFM Class II - UL, cUL
Product option: [o]	1 Z T X Y	Standard product Custom alarm tone software - contact E2S Tropicalisation Custom configuration - contact E2S Stage control Config. 4
Enclosure colour: [x]	G R	Grey Red
Lens colour: [y]	A B C G M R Y	Amber Blue Clear Green Magenta Red Yellow

Accessories:

SP65-0001-A4	Pole Mount Bracket Kit 2" St/St A4 (316)
SP65-0003-A4	Sunshade - St/St A4 (316)

Current Consumption

Nominal Voltage:	Voltage range:	Xenon Strobe Nominal current:	Alarm Horn Nominal current:	Combined Nominal current:	Combined Max. current:
24Vdc	20-28Vdc	323mA	185mA	508mA	555mA
115Vac	110-120Vac 50/60Hz	129mA	73mA	200mA	264mA
230Vac	220-240Vac 50/60Hz	79mA	48mA	127mA	149mA

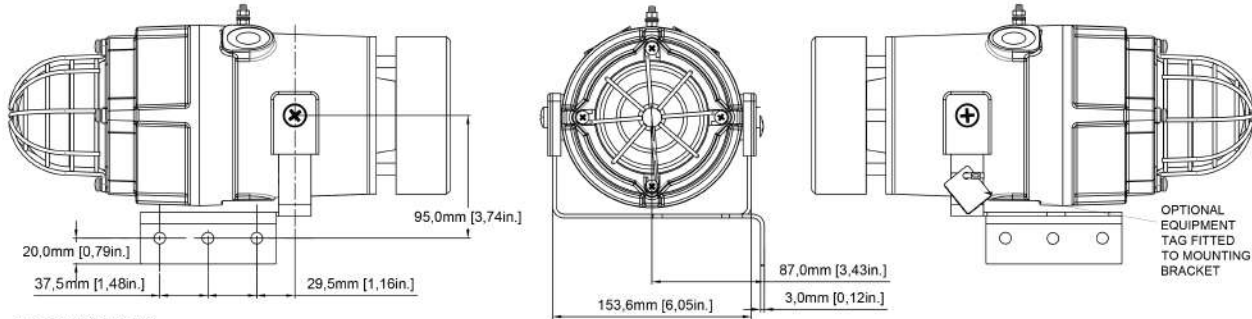

SURFACE BRACKET TYPE

STANDARD BRACKET TYPE

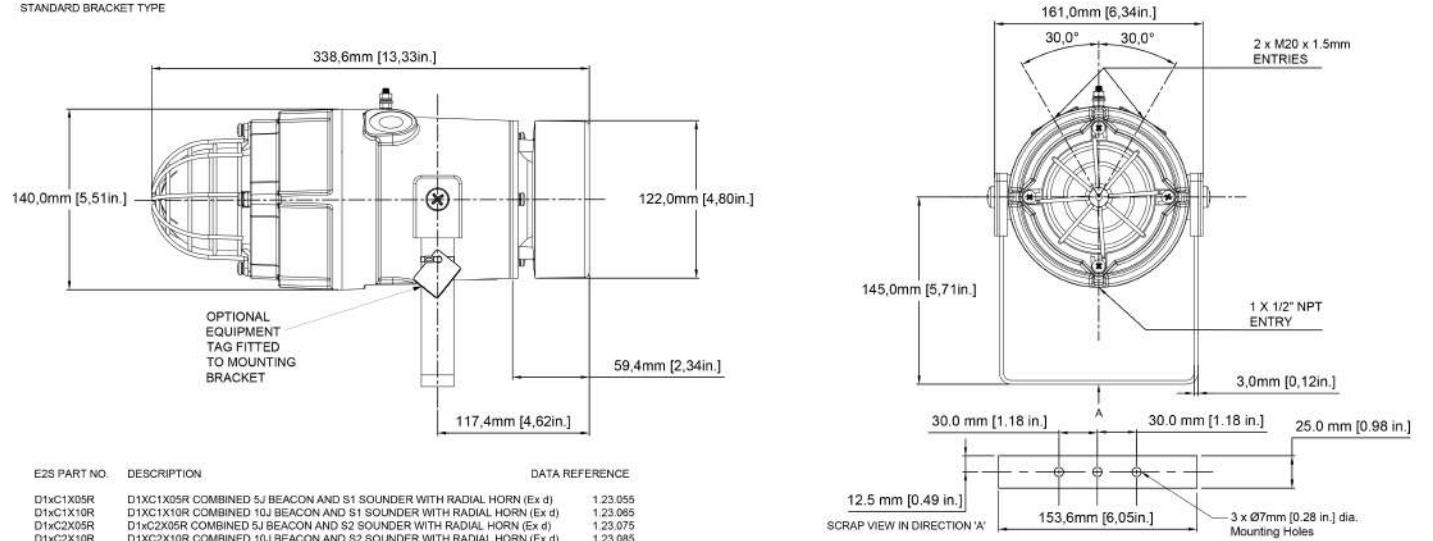

E2S PART NO.	DESCRIPTION	DATA REFERENCE
D1xC1X05R	D1XC1X05R COMBINED 5J BEACON AND S1 SOUNDER WITH RADIAL HORN (Ex d)	1.23.055
D1xC1X10R	D1XC1X10R COMBINED 10J BEACON AND S1 SOUNDER WITH RADIAL HORN (Ex d)	1.23.065
D1xC2X05R	D1XC2X05R COMBINED 5J BEACON AND S2 SOUNDER WITH RADIAL HORN (Ex d)	1.23.075
D1xC2X10R	D1XC2X10R COMBINED 10J BEACON AND S2 SOUNDER WITH RADIAL HORN (Ex d)	1.23.085

SCRAP VIEW IN DIRECTION 'A'
12,5 mm [0,49 in.]
153,6 mm [6,05 in.]
3 x Ø7mm [0,28 in.] dia. Mounting Holes

Tone table

S 1	Description	S 2	S 3	S 4
T1	1000 Continuous PFEER Toxic Gas	Any	T2	T44
T2	1200/500 @ 1Hz Sweeping DIN/PFEER P.T.A.P.	Any	T3	T44
T3	1000 @ 0.5Hz (1s on, 1s off) Intermittent PFE...	Any	T2	T44
T4	1.4KH-1.6KHz 1s, 1.6KHz-1.4KHz 0.5s NF C 48-265	Any	T24	T1
T5	544(100mS)/440 (400mS) NF S 32-001	Any	T19	T1
T6	1500/500 - (0.5s on , 0.5s off) x3 + 1s gap A...	Any	T44	T1
T7	500-1500Hz Sweeping 2 sec on 1 sec off AS4428	Any	T44	T1
T8	500/1200Hz @ 0.26Hz(3.3s on, 0.5s off) NEN 2575	Any	T24	T35
T9	1000 (1s on, 1s off)x7 + (7s on, 1s off) IMO ...	Any	T34	T1
T10	1000 (1s on, 1s off)x7 + (7s on, 1s off) IMO ...	Any	T34	T1
T11	420(0.5s on, 0.5s off)x3 + 1s gap ISO 8201 Te...	Any	T1	T8
T12	1000(0.5s on, 0.5s off)x3 + 1s gap ISO 8201 T...	Any	T1	T8
T13	422/775 (0.85 on, 0.5 off) x3 + 1s gap NFPA T...	Any	T1	T8
T14	1000/2000 @ 1Hz - Singapore	Any	T3	T35
T15	300 Continuous	Any	T24	T35
T16	440 Continuous	Any	T24	T35
T17	470 Continuous	Any	T24	T35
T18	500 Continuous IMO code 2 (Low)	Any	T24	T35
T19	554 Continuous	Any	T24	T35
T20	660 Continuous	Any	T24	T35
T21	800 Continuous IMO code 2 (High)	Any	T24	T35
T22	1200 Continuous	Any	T24	T35
T23	2000 Continuous	Any	T3	T35
T24	2400 Continuous	Any	T20	T35
T25	440 @ 0.83Hz (0.60s on, 0.60s off) Intermittent	Any	T44	T8
T26	470 @ 0.9Hz (0.55s on, 0.55s off) Intermittent	Any	T44	T8
T27	470 @ 5Hz (0.10s on, 0.10s off) Intermittent	Any	T44	T8
T28	544 @ 1.14Hz (0.43s on, 0.44s off) Intermittent	Any	T24	T8
T29	655 @ 0.875Hz (0.57s on, 0.57s off) Intermittent	Any	T44	T8
T30	660 @ 0.28Hz (1.80s on, 1.80s off) Intermittent	Any	T24	T8
T31	660 @ 3.3Hz (0.15s on, 0.15s off) Intermittent	Any	T24	T8
T32	745 @ 1Hz (0.50s on, 0.50s off) Intermittent	Any	T24	T8

S 1	Description	S 2	S 3	S 4
T33	800 (0.25s on, 1.00s off) Intermittent	Any	T24	T8
T34	800 @ 2Hz (0.25s on, 0.25s off) IMO code 3.a ...	Any	T24	T8
T35	1000 @ 1Hz (0.50s on, 0.50s off) Intermittent	Any	T24	T8
T36	2400 @ 1Hz (0.50s on, 0.50s off) Intermittent	Any	T24	T8
T37	2900 @ 5Hz (0.10s on, 0.10s off) Intermittent	Any	T24	T8
T38	363/518 @ 1Hz (0.50s/0.50s) Alternating	Any	T8	T19
T39	450/500 @ 2Hz (0.25s/0.25s) Alternating	Any	T8	T19
T40	554/440 @ 1Hz (0.50s/0.50s) Alternating	Any	T24	T19
T41	554/440 @ 0.65Hz (0.76s/0.76s) Alternating	Any	T8	T19
T42	561/760 @ 0.83Hz (0.60s/0.60s) Alternating	Any	T8	T19
T43	780/600 @ 0.96Hz (0.52s/0.52s) Alternating	Any	T8	T19
T44	800/1000 @ 2Hz (0.25s/0.25s) Alternating	Any	T24	T19
T45	970/800 @ 2Hz (0.25s/0.25s) Alternating	Any	T8	T19
T46	800/1000 @ 0.875Hz (0.57s/0.57s) Alternating	Any	T24	T19
T47	2400/2900 @ 2Hz (0.25s/0.25s) Alternating	Any	T24	T19
T48	500/1200 @ 0.3Hz (1.67s/1.67s) Sweeping	Any	T24	T12
T49	560/1055 @ 0.18Hz (2.73s/2.73s) Sweeping	Any	T24	T12
T50	560/1055 @ 3.3Hz (0.15s/0.15s) Sweeping	Any	T24	T12
T51	600/1250 @ 0.125Hz (4s/4s) Sweeping	Any	T24	T12
T52	660/1200 @ 1Hz (0.50s/0.50s) Sweeping	Any	T24	T12
T53	800/1000 @ 1Hz (0.50s/0.50s) Sweeping	Any	T24	T12
T54	800/1000 @ 7Hz (0.07s/0.07s) Sweeping	Any	T24	T12
T55	800/1000 @ 50Hz (0.01s/0.01s) Sweeping	Any	T24	T12
T56	2400/2900 @ 7Hz (0.07s/0.07s) Sweeping	Any	T24	T12
T57	2400/2900 @ 1Hz (0.50s/0.50s) Sweeping	Any	T24	T12
T58	2400/2900 @ 50Hz (0.01s/0.01s) Sweeping	Any	T24	T12
T59	2500/3000 @ 2Hz (0.25s/0.25s) Sweeping	Any	T24	T12
T60	2500/3000 @ 7.7Hz (0.65s/0.65s) Sweeping	Any	T24	T12
T61	800Hz Motor Siren	Any	T24	T12
T62	1200Hz Motor Siren	Any	T24	T12
T63	2400Hz Motor Siren	Any	T24	T12
T64	Simulated Bell	Any	T21	T12